

Transmitters

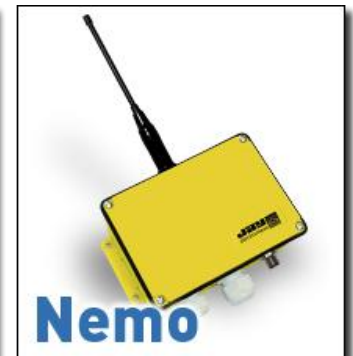

Receivers



Charger and Charger support



TABLE OF CONTENTS

Chapters	Pages
1 --- General safety rules and precautions	8
2 --- Description and operating principle	9
3 --- Functional Safety	10
3.1---Emergency stop function	10
3.2---Safety function stop	10
3.3---Life signal	12
3.4---Safety function information	12
4 --- Transmitter	13
4.1---General view of transmitters	13
4.1.1 -- <i>Gama transmitters</i>	13
4.1.2 -- <i>Beta transmitters</i>	14
4.1.3 -- <i>Pika transmitters</i>	15
4.1.4 -- <i>Moka transmitters</i>	16
4.2---Instructions before use	17
4.3---Using the screen and navigating in the menus	17
4.3.1 -- <i>Information displayed by transmitter screen</i>	17
4.3.2 -- <i>Screen user interface</i>	18
4.4---Commissioning the transmitter	19
4.5---“Association” function (association with a Receiver)	20
4.5.1 -- <i>Searching for Receiver</i>	21
4.5.2 -- <i>Associating a Receiver to a Transmitter</i>	22
4.6---Using the radio control system	23
4.6.1 -- <i>Starting up the radio control system</i>	23
4.6.2 -- <i>Stopping the transmitter</i>	25
4.6.3 -- <i>Function selector</i>	26
4.7---Predefined alert messages	27
4.8---Configuration menu	28
4.8.1 -- <i>Accessing the configuration menu</i>	28
4.8.2 -- <i>Configuration menu summary</i>	29
4.8.3 -- <i>“Identification” menu</i>	30
4.8.3.1 Identity codes	30
4.8.3.2 Serial numbers	30
4.8.3.3 Tables	30
4.8.3.4 Software version of the Transmitter	31
4.8.3.5 Hardware	31
4.8.4 -- <i>“Language” menu</i>	32
4.8.5 -- <i>“Display” menu</i>	33
4.8.5.1 Contrast	33
4.8.5.2 Backlighting	33
4.8.6 -- <i>“Function” menu</i>	34
4.8.6.1 Standby	34
4.8.6.2 Dead man	35
4.8.6.3 Inclinometer	35
4.8.7 -- <i>“Radio” menu</i>	36
4.8.7.1 Power	36
4.8.7.2 Setting the radio channel	37
4.8.7.3 List of available radio frequencies	39
4.8.7.4 Tandem	39
4.8.7.5 Master – Master	39
4.8.7.6 Pitch & Catch 2.0	39
4.8.7.7 Pick & Control 2.0	39
4.8.7.8 MultiDevices	39
4.8.8 -- <i>Test</i>	40
4.8.8.1 Channel scan	40
4.9---Transmitter automatic stop functions	41
4.9.1 -- <i>Standby mode</i>	41
4.9.2 -- <i>“Deadman”</i>	42
4.10 -- <i>Default configuration of transmitter</i>	42
5 --- Charger and Support chargers	43
5.1---WARNING concerning the battery	43

5.2----	Information on battery storage	43
5.3----	Transmitter battery: charge level.....	43
5.4----	General view of charger and support chargers	44
5.5----	Information on battery charge	45
5.6----	Indicator light on charger and support chargers.....	45
5.7----	Supply of chargers and support chargers	46
5.7.1 --	Power supply by voltage adapter.....	46
5.7.2 --	Power supply by external source.....	46
5.8----	Options on chargers	47
5.8.1 --	Concerned models: PWCB021, PWCB061, PWCG061, PWCG101, PWCB022, PWCB062, PWCPM01	47
5.8.2 --	Concerned models: PWCB022, PWCB062.....	48
5.8.3 --	Example of wiring for use of the "all options" load carrier on a vehicle:.....	48
5.8.4 --	Mounting charger bracket PWCB021, PWCB061, PWCG061, PWCG101, PWCB022, PWCB062, PWCPM01	49
5.8.4.1	Attaching the support charger.....	49
5.8.5 --	Load and work support for PIKA or MOKA Manipulators: PWCPM01	51
5.8.5.1	Technical data.....	51
5.8.5.2	Attaching the load support.....	51
6 ---	Receiver	52
6.1----	General view of Receivers	52
6.1.1 --	Elio Receiver	52
6.1.1.1	Wire terminal strips for Elio Receiver	53
6.1.2 --	Alto Receiver	54
6.1.2.1	Wiring terminal strips of Alto Receiver	55
6.1.2.2	Board with 12 control relay outputs.....	56
6.1.2.3	Board with 12 On/Off inputs + 2 analogue inputs.....	56
6.1.2.4	Board with 6 analogue outputs + 1 BYPASS output.....	56
6.1.3 --	Timo Receiver	57
6.1.3.1	Wiring terminal blocks of Timo Receiver.....	58
6.1.3.2	End line configuration panel for CANopen and RS485 links.....	59
6.1.3.3	CANopen link configuration: Addressing.....	59
6.1.3.4	CANopen link configuration: data rate.....	60
6.1.4 --	Receiver Nemo.....	61
6.1.4.1	Wiring terminal blocks of Nemo Receiver.....	62
6.1.4.2	End line configuration panel for CANopen and RS485 links.....	64
6.1.4.3	Addressing configuration for CANopen, MODBUS, PROFIBUS ² and POWERLINK.....	64
6.1.4.4	CANopen link configuration: data rate.....	65
6.1.4.5	End line configuration panel for options: DEVICENET or PROFIBUS-CCLINK	65
6.1.4.6	Meanings of LEDs	66
6.2----	SIM card	70
6.3----	USB connection.....	71
6.4----	Receiver indicator light functions and messages	71
6.5----	Use of safety relay RSF3	72
7 ---	Options and special functions	73
7.1----	"Start-up by infrared validation" function	73
7.1.1 --	Examples of PWT20 IR modules positioning.....	74
7.2----	"Area limitation by IR" function	75
7.3----	"Association and selection by infrared" function.....	75
7.4----	Cable link between Transmitter / Receiver	76
7.5----	"Tandem synchronised command" function	77
7.5.1 --	Operating principle	78
7.5.2 --	Use.....	79
7.5.3 --	System Shutdown.....	79
7.5.4 --	Associating the Transmitter with Receivers.....	79
7.5.5 --	Changing the radio channel on a Receiver.....	80
7.6----	"Master – Master synchronised command" function	81
7.6.1 --	Operating principle	82
7.6.2 --	Use.....	83
7.6.3 --	Change to operating mode and system shutdown.....	84
7.6.4 --	Procedure for associating Transmitters / Receivers	84
7.6.5 --	Procedure to change radio channel.....	85
7.6.6 --	Compatibility with "Start up by infrared validation" option.....	86
7.7----	"Pitch & catch 2.0" function	87
7.7.1 --	Operating principle	87
7.7.2 --	Use.....	87
7.7.3 --	System shutdown (and release)	88
7.7.4 --	Configuration	88
7.7.5 --	Associating a Transmitter with the Receiver.....	88
7.7.6 --	Changing the radio channel.....	88

7.7.7 --Replacing a Transmitter (backup model)	89
7.7.8 --Replacing the Receiver	89
7.8---“Pick & Control 2.0” function.....	90
7.8.1 --Association in “Pick & Control 2.0”	91
7.8.2 --Creation and modification of the list.....	91
7.8.2.1 “Edit” menu.....	94
7.8.2.2 “Send” menu.....	97
7.8.2.3 “Receive” menu.....	97
7.8.2.4 “Remove” menu.....	98
7.8.3 --Exploitation.....	99
7.8.4 --Exploitation stop.....	101
7.8.5 --Rest channel and operating channel.....	102
7.8.6 --List transfert from transmitter to transmitter.....	102
7.9---“MultiDevices” function.....	103
7.9.1 --Association in “MultiDevices”.....	104
7.9.2 --Creation and modification of the list.....	104
7.9.2.1 “Edit” menu.....	106
7.9.2.1 “Send” menu.....	109
7.9.2.2 “Receive” menu.....	109
7.9.2.3 “Remove” menu.....	110
7.9.3 --Exploitation.....	111
7.9.4 --Exploitation stop.....	113
7.9.5 --Rest channel and operating channel.....	113
7.9.6 --List transfer from transmitter to transmitter.....	114
7.10 --"Frequency agility" automatic channel change function.....	115
7.11 --"Radio power regulation" function.....	116
7.12 --"Deadman" function (detection of operator inactivity).....	116
7.12.1 -Manual detection of operator activity.....	116
7.12.2 -Automatic detection of operator inactivity by inclinometer (option).....	116
7.12.3 -Vibrator (option).....	116
7.12.4 -Configuration.....	117
7.12.5 -Use.....	117
7.13 --“Filtering of commands and anti-tapping” option.....	118
7.14 --“Multimode 3” and “Multimode 32” options.....	118
7.15 --“Inclinometer” function.....	119
7.15.1 -Configuration.....	119
7.15.2 -Use.....	120
8 --- Instructions for installation and commissioning.....	121
8.1----Instructions for electrical connection of the receiver.....	121
8.1.1 --Multi-strand wires: use of wire end ferrules is mandatory.....	122
8.2---Connecting the power supply.....	123
8.3---Installing the Receiver.....	124
8.3.1 --Positioning the Receiver.....	124
8.3.1.1 Example: Double girder travelling cranes and couples travelling cranes.....	124
8.3.2 --Antennas.....	125
8.3.2.1 418-419MHz and 433-434MHz Bands.....	125
8.3.2.2 869MHz band.....	126
8.3.2.3 911-918MHz band: authorized antennas according to FCC Part 15.204.....	127
8.3.2.4 2.4GHz band: authorized external antennas according to FCC Part 15.204.....	128
8.3.3 --Mounting the Receiver.....	129
8.4---Wiring diagram: use of safety relays RS1 and RS2.....	130
8.5---Instructions for commissioning.....	130
9 --- Maintenance.....	131
9.1---Replacement of a transmitter or of a Receiver.....	131
9.1.1 --Transmitters.....	131
9.1.2 --Receiver.....	131
9.2---USB connector.....	131
9.3---Chargers.....	131
9.3.1 --Indicator light on support chargers does not come on.....	131
9.3.2 --Transmitter does not charge on its support charger.....	131
10 - Inspection and servicing.....	132
10.1 --Inspection and servicing of transmitter.....	132
10.2 --Inspection and servicing of charger.....	132
10.3 --Inspection and servicing of Receiver.....	132
11 - Technical characteristics.....	133

11.1 --Transmitters.....	133
11.2 --Receivers.....	134
11.2.1 -Receiver Alto: Control board characteristics.....	136
11.2.2-Receiver Alto: Additional board characteristics.....	137
11.2.3-Receiver ELIO: CONTROL Board.....	138
11.2.4-Receiver ELIO: Extension board features (option).....	138
11.2.5-Receiver Timo: Inputs/Outputs and features.....	139
11.2.6-Receiver Nemo: Inputs/Outputs and features.....	140
12 - Warranty.....	141
13 - FCC Rules & Regulations (Federal Communications Commission).....	142
14 - IC Regulations (Industry Canada).....	143
15 - TAIWAN NCC Regulations (National Communications Commission).....	144
15.1 --General; 一般的.....	144
15.2 --Regulations; 规定.....	144
15.3 --Features; 特征.....	144
16 - Safety parameters.....	145
16.1 --Parameters calculated according to EN ISO 13849-1 and EN ISO 13849-2.....	145
16.2 --Parameters calculated according to EN 61508 and EN IEC 62061.....	148
16.3 --“Stop times” characteristics.....	151
16.4 --Joystick command characteristic.....	151
17 - Environmental characteristics.....	152
18 - Residual risks.....	152
19 - Forseeable misuse.....	152
20 - Product references.....	152
21 - Waste recycling and management.....	152
22 - Manufacturer information.....	152
23 - Declarations EU of conformity.....	153
23.1 --Beta – Declaration EU of conformity.....	153
23.2 --Gama – Declaration EU of conformity.....	154
23.3 --Moka – Declaration EU of conformity.....	155
23.4 --Pika – Declaration EU of conformity.....	156
23.5 --Alto – Declaration EU of conformity.....	157
23.6 --Elio – Declaration EU of conformity.....	158
23.7 --Timo – Declaration EU of conformity.....	159
23.8 --Nemo – Declaration EU of conformity.....	160

Thank you for choosing JAY Electronique for your radio control system. Your configuration has been defined for your application to ensure easy use and maintenance while providing the highest level of safety.





The various components forming your **JAY Electronique** radio control system are designed to meet the safety requirements of the currently applicable and draft standards and are compliant with the European directives (see section "[Declaration EU of conformity](#)").

For all questions concerning installation or use of your radio control system, contact our "**Customer Service**" service: Monday to Friday

Tel: + 33 (0)4.76.41.44.00

Email: customer.services@conductix.com

Terms and symbols used in this manual:

Control component	Refers to any control component of the transmitter used by the operator to radio control the Receiver by radio link (such as: <i>single-action pushbuttons, double-action pushbuttons, rotary switches, selectors, joysticks, proportional toggle switches, etc.</i>)
	On Transmitter: Black pushbutton with diamond symbol: "tab" navigation function
	On Transmitter: Black pushbutton with square symbol: "increment" function
	On Transmitter: Green pushbutton with round symbol: "validate" function
	Exclamation point in triangle. This symbol indicates that you must observe the operating and maintenance instructions given in the manual.
	Lightning in triangle. This symbol is used to warn you of a hazardous un-insulated voltage. This voltage can cause a dangerous electrical shock. The symbol indicates that the equipment must not be opened (such as the Receiver unit) when powered up.
	The terms MO and MT are frequently used on the displays of radio controls. - MO stands for Operator Module or Transmitter - MT stands for Transceiver Module or Receiver

1 General safety rules and precautions

A radio control system is considered as a machine control device and as a safety component used to stop a machine as specified by the EEC Machinery Directive. All applicable rules must therefore be observed to ensure safe, correct operation of such devices.

**The use of the radio control system enables the operator to better focus on his work as it allows him to choose his observation position which is only limited by safety considerations (example: no one should be standing under a load).
The radio remote control completes and enhances the classic safety circuits (emergency stop circuits).**

- **To ensure safe use, the instructions given in this manual must be strictly observed.**
- The operator must be appropriately trained and certified to operate machines by radio control.
- The operator must have uninterrupted visibility of the manoeuvre which he is performing. When the operator's direct field of view is inadequate, the lifting machinery must be equipped with auxiliary devices to improve visibility.
- When several machines are being moved simultaneously, the equipment must be fitted out to limit to consequences of a possible collision
- To avoid any risks of electrocution, don't open the Receiver housing when powered. The opening of the housing must be done by ensuring that the power supply cables, and control cables are out of voltage.
- Never leave the transmitter unattended in any haphazard location, even though it is equipped with a "Standby Mode" function which automatically cuts out the system.
- Never leave the transmitter to sunlight (eg vehicle windscreens), or near a heat source.
- If several radio controls are used at the same site, different radio frequencies should be used.
- In the event of a malfunction, immediately shut down the installation by pressing the stop palmswitch on the transmitter and remove the battery.
- The stop palmswitch should be manipulated to check if it is functional at least once a year.
- Service your equipment and perform all the periodic checks as may be required by the intensity with which your equipment is used. Follow necessarily the instructions of cleaning described in the chapter ***"Inspecting and servicing"***.
- Take all possible precautions so that a malicious intelligence equipped with means of recording and replaying radio exchanges cannot take control of the installation by spoofing the command of the transmitter associated with the receiver.

2 Description and operating principle

A radio control assembly is formed by two components: a **transmitter** (for example: “**Gama**“ type) and a **receiver** (for example: “**Elio**“ type).

The **transmitter** transmits the commands to the **receiver** which decodes the commands and puts them into action in accordance with its outputs (relay, analogue or BUS outputs).

The radio link between the **transmitter** and the **receiver** is a 2-way link; this allows return of **receiver** inputs/outputs information used for radio control.

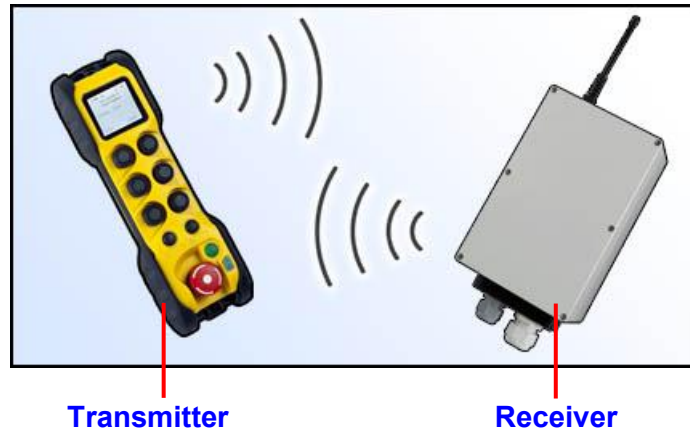

Example:



The **receiver** contains the configuration of the **transmitter** corresponding to the application (also referred to as the “application memory”). A simple association procedure is required to allow the **transmitter** to recover the application configuration.

The link between the two elements is ensured through “**identity codes**” (unique, frozen code, stored in each product).

The **transmitter** is formed by:

- A display screen,
- A safety stop palmswitch,
- A green pushbutton (for “On” and “Validate” functions) ,
- A black “tab” navigation pushbutton ,
- A black “increment” pushbutton ,
- And control components corresponding to the configuration required for the application (such as: single and double-action pushbuttons, rotary switches, selectors, joysticks, etc.)

The **Receiver** is formed by:

- Two safety relays,
- An “On” relay,
- And inputs/outputs corresponding to the configuration required for the application.

3 Functional Safety

3.1 Emergency stop function

The **STOP function** leads to the safe position of the Wireless Remote-Control System when the operator presses the **Emergency STOP** red mushroom button.

By activating the emergency stop button:

- The remote control will be shut down.
- The state of the safety relay on the receiver will be **OFF**.

The undesired event of the **Emergency Emergency STOP function** is the non-execution of the Emergency STOP function.

The safe state of the **Emergency STOP function** is to open safety relays.

In case of loss of communication or incorrect frame receive, the receiver goes in passive stop time and the state of the safety relays turn open after a delay defined by iDialog. To know the different timing, please check the chapter **“16.3 “Stop times” characteristics”**.

The performance level and safety parameters of the **Emergency stop function** are described in the chapter: **“16 Safety parameters”**.

3.2 Safety function stop

The **safety function stop** leads to checking the neutral position of an actuator to prevent an unwanted action of the machine.

When all the safety actuators are released, the functional safety relay state is **OFF**.

The undesired event of the **Actuator safety function** is sending an unwanted order to the machine while all safety actuators are in neutral position.

The safe state of the **Actuator safety function** is to open the functional safety relay.

The safety relevant actuators are defined by iDialog. To know how to configure a safety input, please check the iDialog user manual.

The **Actuator safety function** is split into 3 types of safety actuator depending on the operator module:

- **“Dual way” input:**

To send a safety order to the receiver to let him state the functional safety relay to ON. The user must press at least 2 actuators.

The Dual_way inputs are:

- On BETA: F1 to F6, N1, N2, A13.
- On GAMA: N1, N2
- On PIKA/MOKA: F1 to F4, N1, N2, V1, V2, V3, C1_1, C1_2, A13.
-

To be in safe state, all dual-way input defined as safety relevant must be in neutral position (unpressed).

- Activation time: 189 ms
- In case of failure, safe state will occur in 675 ms + passive stop time.

● **Function button - Safety button / enable switch**

To send a safety order to the receiver to let him state the functional safety relay to ON. The user must press at least 1 actuator.

This function is only available on PIKA/MOKA.

- The safety button/Enabling switch is: A14.

This function is only available on GAMA.

- The function buttons are: F1 to F10.

To be in safe state, all dual way/Function button/Safety button/Joystick defined as safety relevant must be in neutral position (unpressed, or on third position for Enabling Switch).

- Activation time: 189 ms
- In case of failure, safe state will occur in 675 ms + passive stop time.

● **Joystick**

To send a safety order to the receiver to let him state the functional safety relay to ON. The user must press at activated at least 1 joystick.

This function is only available on PIKA/MOKA.

- The Joysticks are: J1, J2, J3.

To be in safe state, all dual way/Function button/Safety button/Joystick defined as safety relevant must be in neutral position (unpressed/joystick release).

- Activation time: 189 ms
- In case of failure, safe state will occur in 675 ms + passive stop time.

● **Functional safety relay**

The **functional safety relay** is available on ALTO and NEMO. The functional safety relay must be placed in series with the function relays. Please check chapter §6.5.

The performance level and safety parameters of the actuator safety function are described in the chapter “16 Safety parameters”.

Delays if the functional safety relay is in failure: 378 ms



The functional relay R1, R2 or functional relay on ALTO are not part of the safety function. Only RSF3 and RZ are monitored.

RSF3 and RZ must be placed to cut the power supply which go throw the functional relay.

To know how to configure RZ and RSF3, please check the iDialog user manual.

Please make sure to define RZ and RSF3 as safety relay to use the safety function "dual-way" input, safety button or Joystick.

Please, check the parameters of the product before started it. More information inside chapter 5.7.9.1 Procedure in iDialog user manual

3.3 Life signal

A **Life signal** can be used in Master-Master mode and Tandem mode. The life signal allows to not activate the functional safety-relay if the other MT is in failure or if no radio frame is received from the other MT. This function must be associated with the actuator safety function to not let a MT move without the other. The life signal can be configured by iDialog.

The performance level and safety parameters of the life signal are described in the chapter: **“16 Safety parameters”**.

- Maximum delay between MT stops when configured in “Master – Master” or “Tandem”: 1189 ms
- Maximum delay between MT stops when configured in “MultiDevices”: 170ms + 170ms x Nb MTs

3.4 Safety function information

- **Safety function icon**

The safety function is available if at start-up the MO displays the following icon:

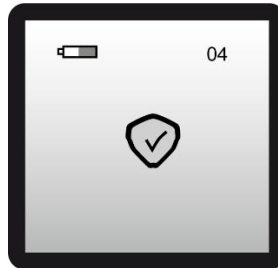

Warning: If the icon is not displayed at start-up and you have set the safety function, please contact the customer services

- **Safety relevant input:**

The information of which safety input as been set is present inside the menu “configuration -> test -> bouton”.

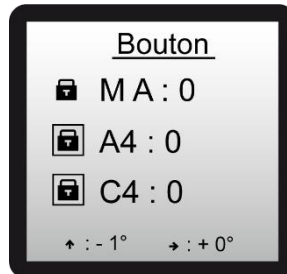

When an input is pressed, if the icon is displayed, that means the input has been configured as safety relevant on an exploitation mode.

The input will block the start-up and the change of exploitation mode if activated.

4 Transmitter

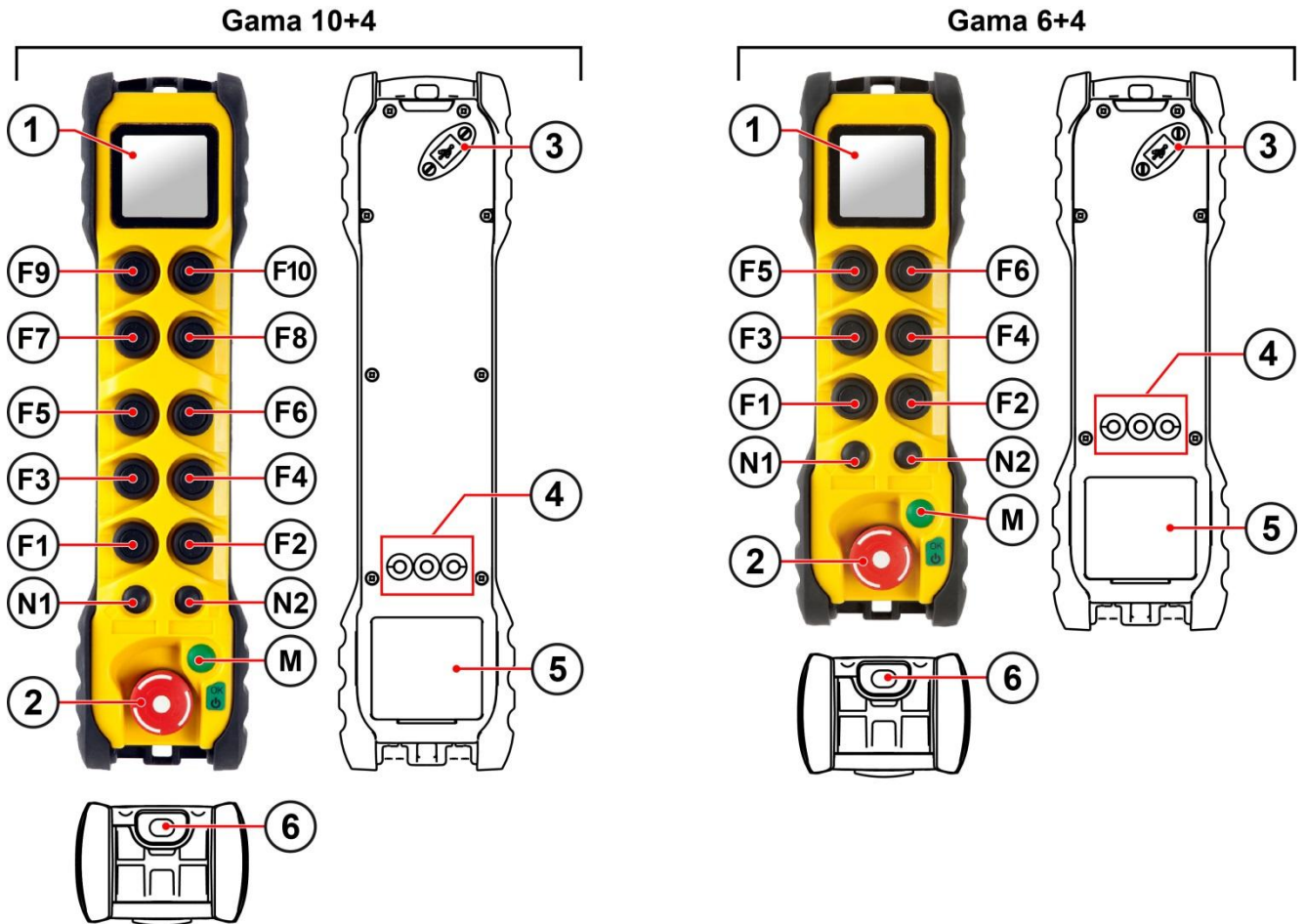

4.1 General view of transmitters

4.1.1 Gama transmitters



1	Screen
2	Emergency stop palmswitch
3	Access to the USB connection
4	Contacts for recharging battery (support charger)
5	Plug-in battery
6	IR cell (option "start-up by infrared validation")

F1 to F10	Function buttons with single or double action
-----------	---

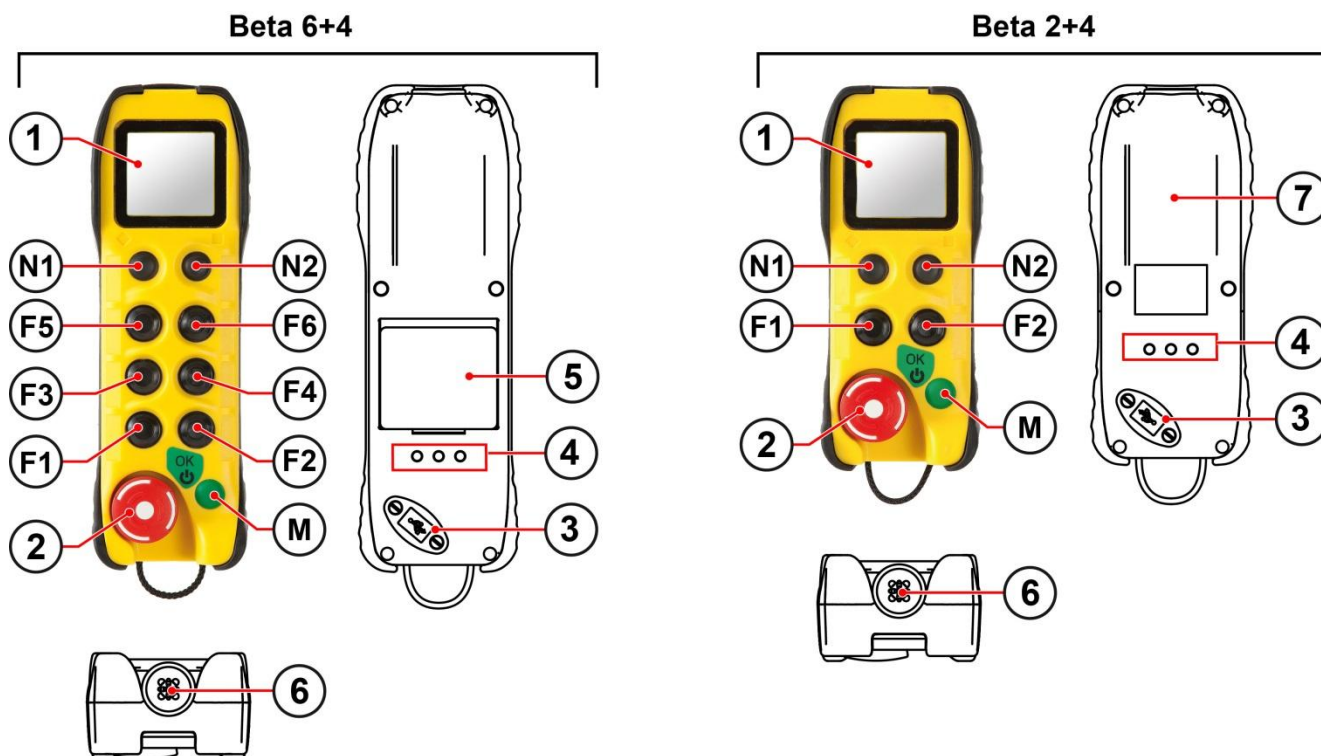

N1	Browsing pushbutton "Tab" 
N2	Input pushbutton "Increment" 
M	Pushbutton "ON" and "Validation" 

4.1.2 Beta transmitters



1	Screen
2	Emergency stop palm switch
3	Access to the USB connection
4	Contacts for recharging battery (support charger)
5	Plug-in battery
6	Location for optional element (IR cell, antenna, etc...)
7	Internal battery

F1 to F6	Function buttons with single or double action
-----------------	---

N1	Browsing pushbutton "Tab" 
N2	Input pushbutton "Increment" 
M	Pushbutton "ON" and "Validation" 

4.1.3 Pika transmitters

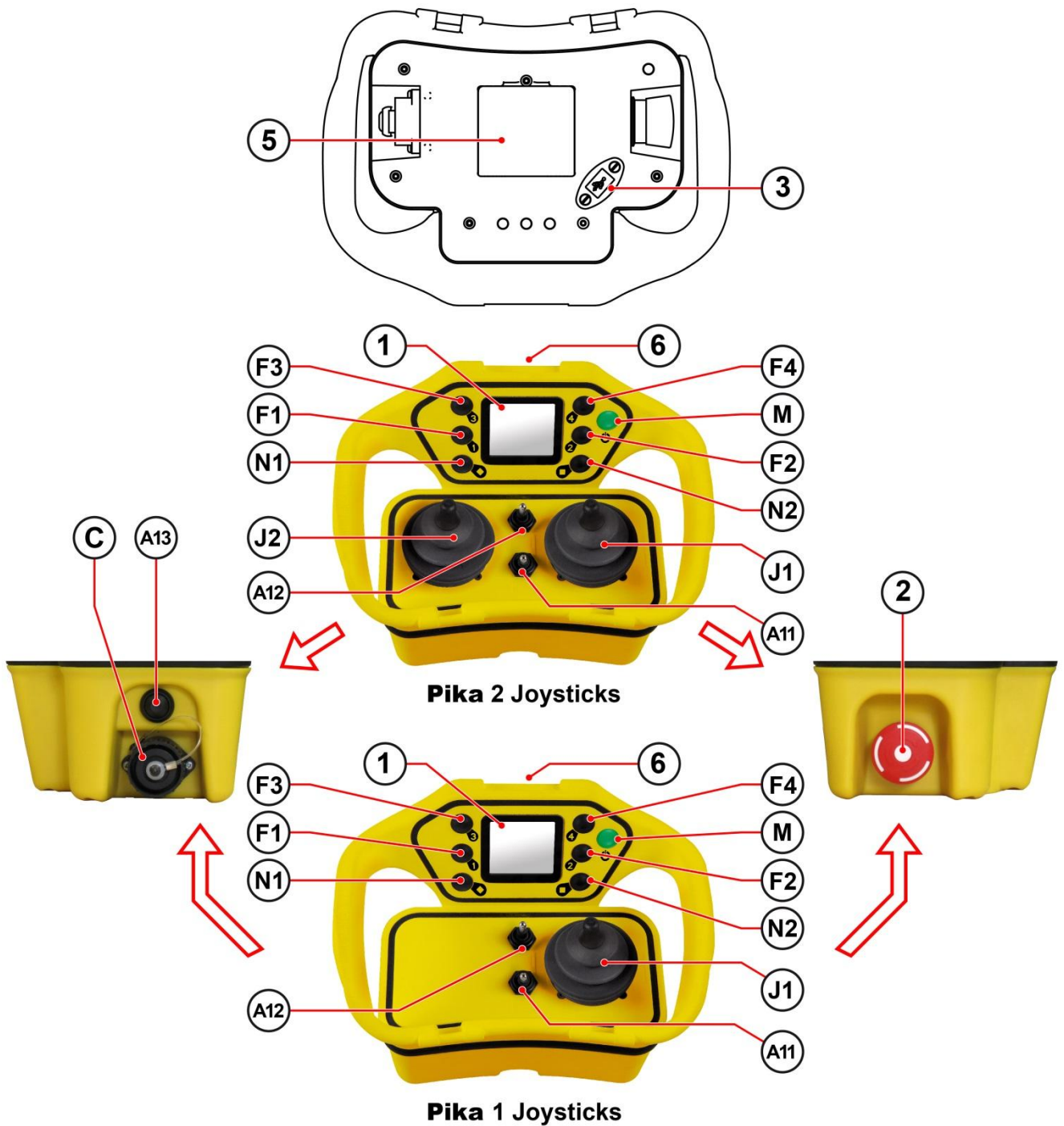

1	Screen
2	Emergency stop palmswitch
3	Access to the USB connection
4	Plug-in battery
5	IR cell (option "start-up by infrared validation")
A13	Location for optional element: pushbutton
C	Location for optional element: industrial connector

N1	Browsing pushbutton "Tab"
N2	Input pushbutton "Increment"
M	Pushbutton "ON" and "Validation"
F1 to F4	Function buttons with single action
A11 and A12	Auxiliary control devices (selector, pushbutton, rotary switch, etc...)
J1 and J2	Joysticks (optional validation button)

4.1.4 Moka transmitters

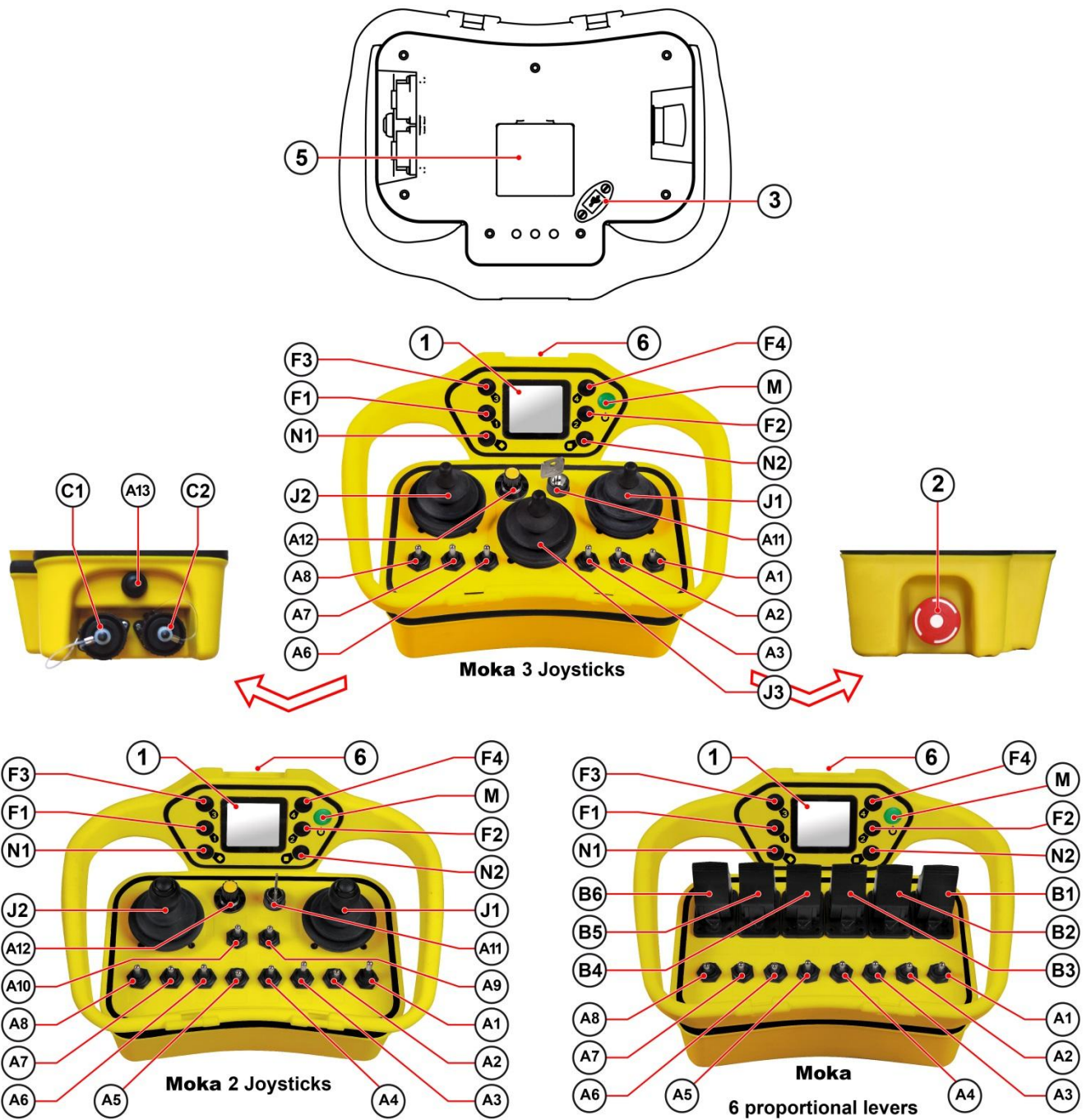

1	Screen
2	Emergency stop palmswitch
3	Access to the USB connection
4	Plug-in battery
5	IR cell (option "start-up by infrared validation")
A13	Location for optional element: pushbutton
C1	Location for optional element: industrial connector
C2	Location for optional element: industrial connector

N1	Browsing pushbutton "Tab"
N2	Input pushbutton "Increment"
M	Pushbutton "ON" and "Validation"

F1 to F4	Function buttons with single action
A1 to A12	Auxiliary control devices (selector, pushbutton, rotary switch, etc...)
J1 to J3	Joysticks (optional validation pushbutton)
B1 to B6	Toggle switches

4.2 Instructions before use

- **At reception of the product**, you must completely charge the battery. To charge the battery, use the battery charger alone or the support charger of the transmitter. Refer to the section “**Chargers and Charger supports**” for information concerning use.
- **The installer must** check that the control components of the transmitter are properly matched up with the control outputs for the application using the “**Configuration sheet**” supplied with the radio-control system (PDF file on a USB keycard).

4.3 Using the screen and navigating in the menus

4.3.1 Information displayed by transmitter screen

The transmitter screen is used to display text and pictograms to facilitate use of the equipment.

During use, the screen has 12 display areas:

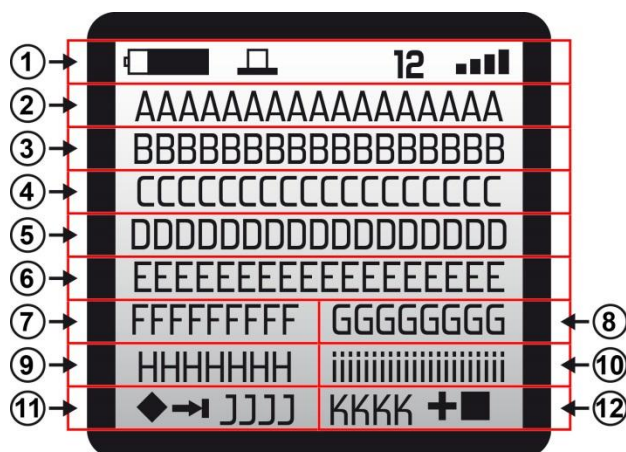



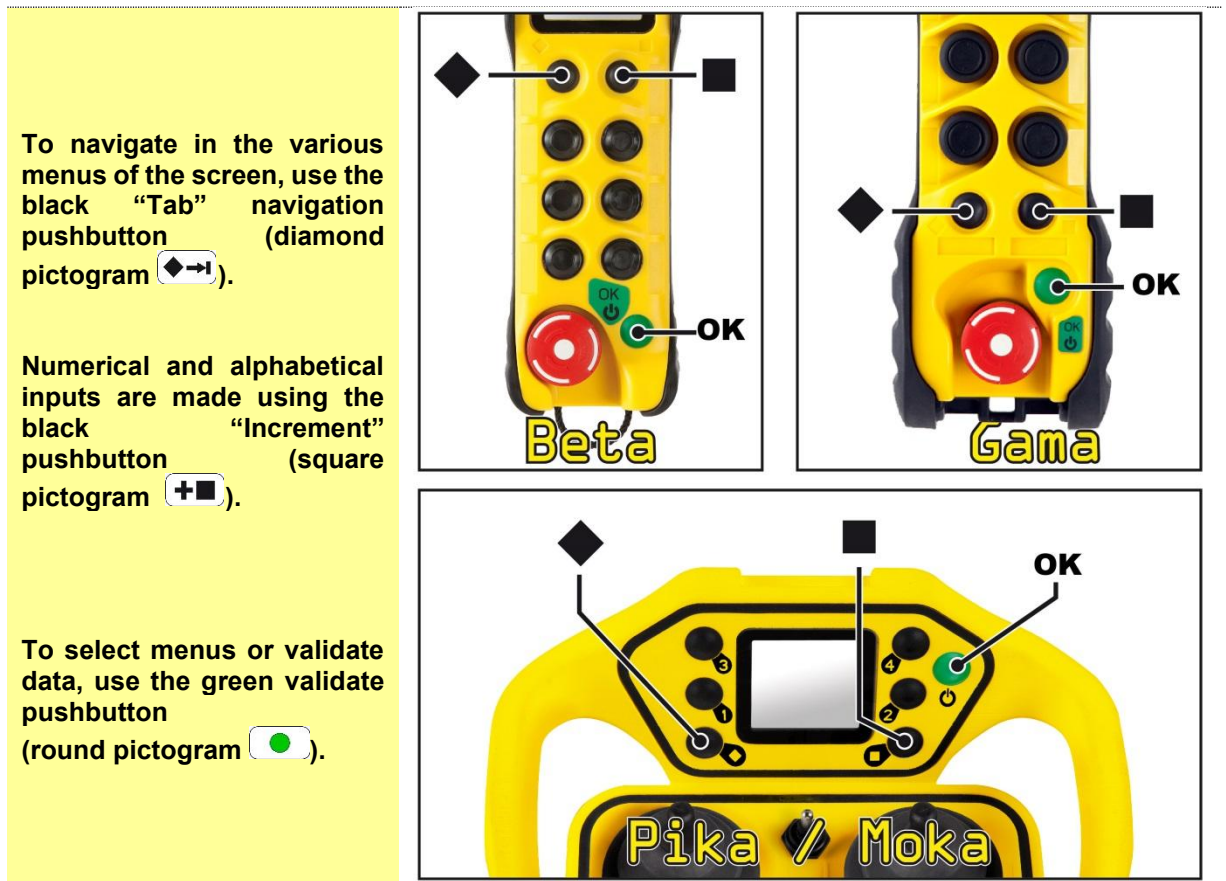

Area	Description
1	Information relative to radio control system status: = « Battery level » pictogram = « Control component position status » pictogram 12 = Radio channel currently being used = Quality of radio link between Transmitter and Receiver
2	Name of radio-controlled equipment
3	Name of operating mode (line No. 1)
4	Name of operating mode (line No. 2) or receiver information No. 1 return
5	Receiver information No. 1 or No. 2 return
6	Receiver information No. 2 or No. 3 return
7	Name of function or selection No. 5
8	Name of function or selection No. 6
9	Name of function or selection No. 3
10	Name of function or selection No. 4
11	Name of function or selection No. 1 Display of pictogram when required by menus
12	Name of function or selection No. 2 Display of pictogram when required by menus

4.3.2 Screen user interface

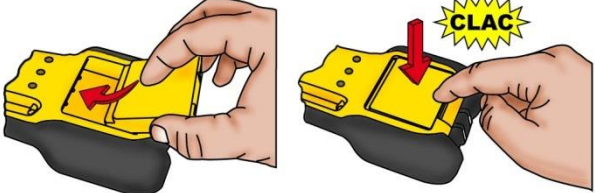

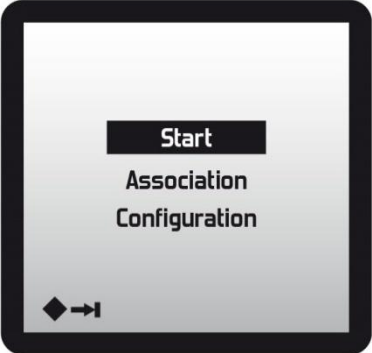

4.4 Commissioning the transmitter

1	Place a charged battery in the transmitter unit or make sure that the battery in the transmitter is charged (for Beta 2+4 model).	
2	Unlock the emergency stop palmswitch.	
3	Press and release the green « On » pushbutton  .	
4	The transmitter home screen should display the following information.	
5	Description of menus proposed: Start : This menu is used to generate an installation startup command to the Receiver. IMPORTANT: the association procedure must be completed beforehand. Association : This procedure is carried out during commissioning to associate the Transmitter to the Receiver(s). Configuration : This menu is used to configure certain settings on the radio control system.	
6	Before any use, perform the “ ASSOCIATION ” procedure detailed in the next section “ Association function ”.	

4.5 “Association” function (association with a Receiver)

The “**Association**” function is used to search for and identify the Receivers located in the vicinity of the transmitter and to select one from the list displayed. This function is used to configure the transmitter with the application parameters contained in the Receiver.

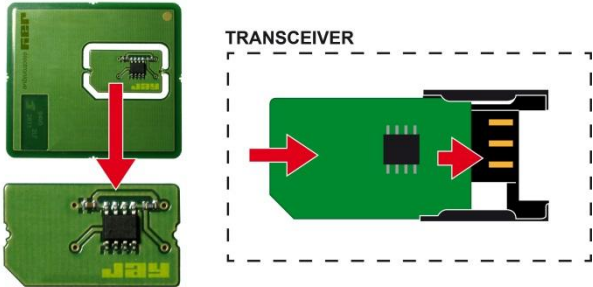
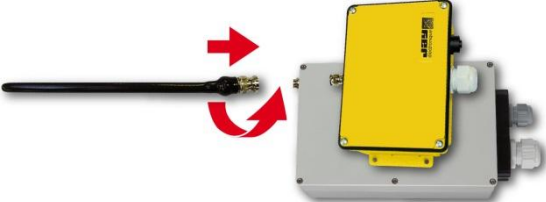
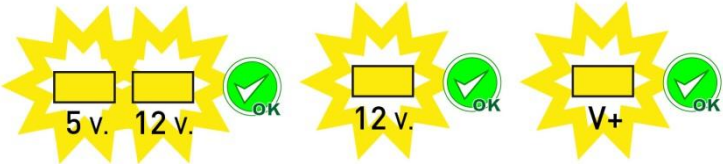
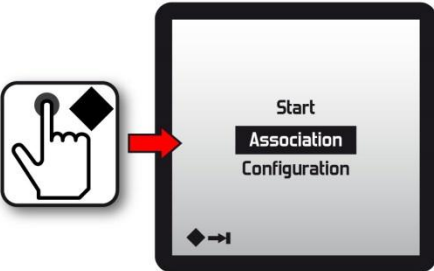
Note: During the Receiver search phase, the transmit range of the Transmitter is reduced to prevent unintentional selection of a Receiver located outside the user’s view.

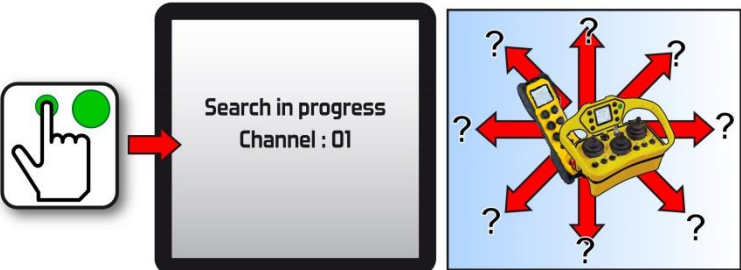
<p>1</p>	<p>Insert the SIM card in the Receiver. (See section “Receiver” for more information concerning the SIM card.)</p>	
<p>2</p>	<p>Receiver with “external antenna”: Connect the antenna into the BNC connector on Receiver</p>	
<p>3</p>	<p>Connect the Receiver to the power supply and Switch on the Receiver. (See section “Receiver” for more information concerning the electrical wiring)</p>	<p>Alto Elio Timo/Nemo</p> 
<p>4</p>	<p>Switch on the transmitter and select the “Association” menu on the home screen</p>	
<p>5</p>	<p>Press the green validate pushbutton  to initiate the receiver search.</p>	

The transmitter will search for receivers located in the vicinity on all the available radio channels

4.5.1 Searching for Receiver

When a Receiver has been found and identified, the transmitter screen indicates:

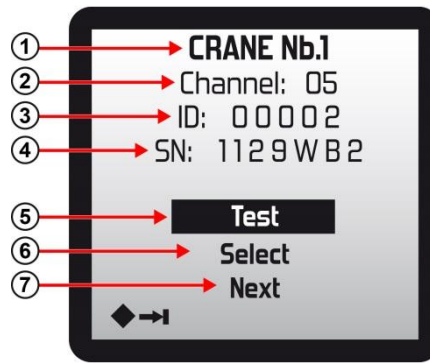

- 1) The name of the radio-controlled equipment
- 2) The radio channel used by the radio-controlled application
- 3) The identity code of the Receiver identified
- 4) The serial number of the Receiver identified
- 5) Choose **“Test”** to test the Receiver identified before you make a definitive association. This action will generate an activation command to the relay associated with the green validate pushbutton , as:

- Receiver **Alto**: the relay **RM** is activated
- Receiver **Elio**: the relay **RM** is activated
- Receiver **Timo/Nemo**: the green indicator light **LD2 “RADIO”** comes on

Note: A light or sound warning device should be connected to the output to facilitate the Receiver test.

- 6) Choose **“Select”** to access the menu used to associate the Transmitter with the Receiver identified (see next section **“Associating a Receiver to a Transmitter”**)



IMPORTANT: it is essential to check that the Receiver selected is the one you want, in order to avoid any risk of controlling another Receiver located near the work zone.

- 7) Choose **“Next”** to continue the search for the Receiver on the other radio channels.

If no Receiver has been found or identified, the **“No Receiver Module”** message displayed. You must press the emergency stop palmswitch.

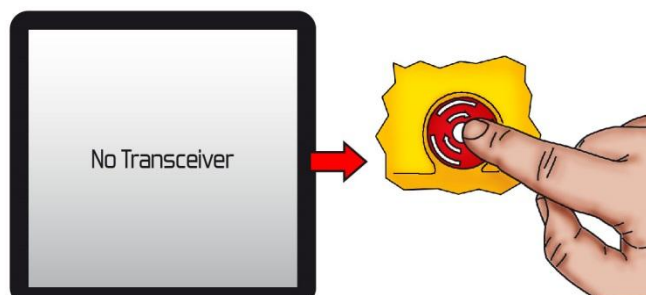

4.5.2 Associating a Receiver to a Transmitter

Once the Receiver search has been successfully completed (see previous section), use the **“Select”** menu to associate the Transmitter with the Receiver.



Choose **“Previous”** to return to the Receiver search function.

Chose **“Transfer”** to initiate the association procedure during which the application configuration parameters contained in the Receiver are transmitted by radio to the Transmitter.

IMPORTANT: Do not switch off the Receiver power supply during this step.

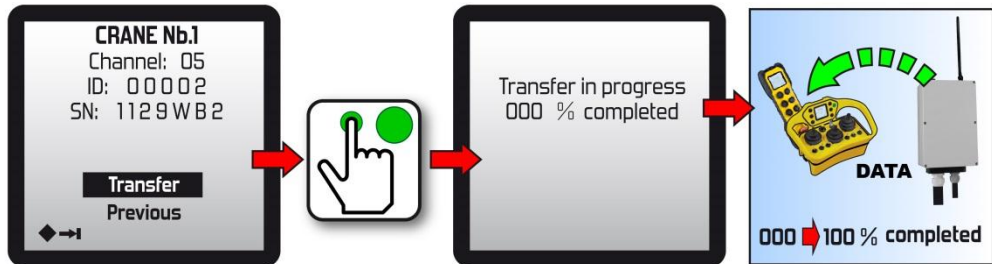

The transmitter will then Synchronise the data saved in the transmitter. Once the check is completed, if the procedure has taken place correctly, the **“Parameters OK”** message is displayed and by choosing **“Validation”**, the transmitter power supply is switched off:

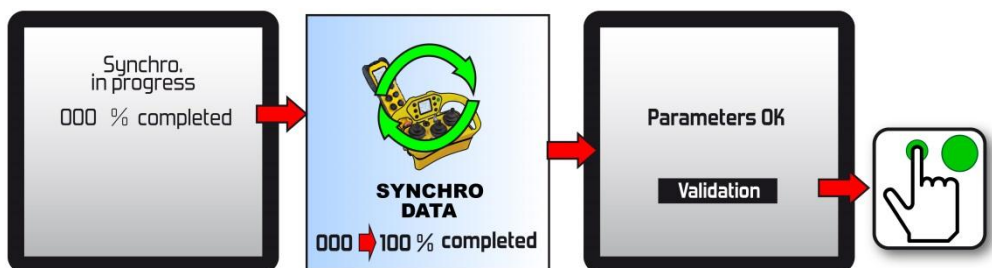







Note: The maximum time required for an association is around 3 minutes.

Note: It is possible to secure (prohibit or authorise) the **“Association”** function with a PIN code. See the **iDialog** software documentation ref 351910.

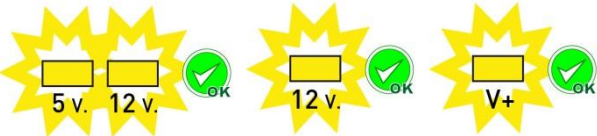
4.6 Using the radio control system

4.6.1 Starting up the radio control system

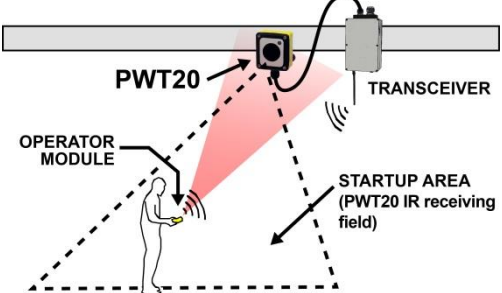
IMPORTANT: Before using the system, make sure the Transmitter has been associated with a Receiver; proceed as instructed in the **“Association Function”** section.

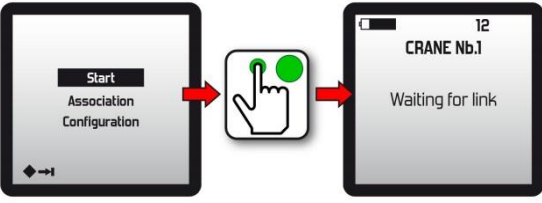
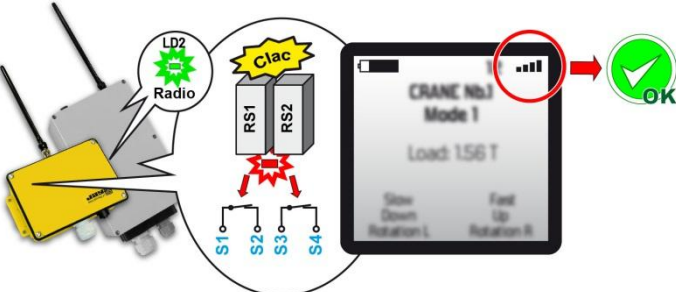
<p>1</p>	<p>Switch on the Receiver</p>	<p>Alto Elio Timo/Nemo</p> 
<p>2</p>	<p>Unlock the emergency stop palmswitch.</p>	
<p>3</p>	<p>Press and release the green “On” pushbutton .</p>	
<p>4</p>	<p>If the radio control system is equipped with feature “startup by infrared validation”, the transmitter must be placed in the « startup area » and must point in the direction of PWT20 IR module(s).</p> <p>(See section “Option: Startup by IR validation feature”)</p>	
<p>5</p>	<p>Select the “Start” menu on the home screen and press the green “On” pushbutton .</p>	
<p>6</p>	<p>Once the link between the Transmitter and the Receiver has been set up, the safety relays of the Receiver are activated (RS1 and RS2).</p> <p>The equipment can be radio-controlled.</p>	

If the radio link has not been established within 8 seconds, the following message is displayed:

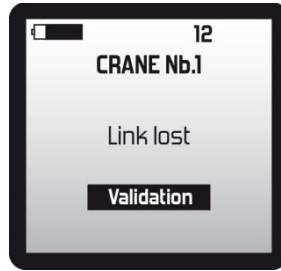

Press the “On” validate button  to return to the transmitter home screen.

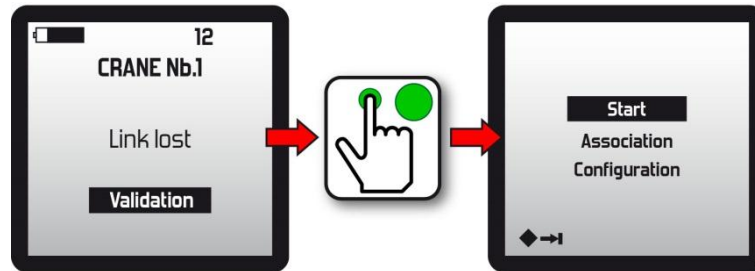

Note: During use, if no control component has been actuated over a certain period of time, the “Standby Mode” function is triggered, causing the transmitter to stop and passive stopping of the Receiver.

Refer to section [“Transmitter automatic stop function”](#).

Note: Access to the **“Start”**, **“Association”** and **“Configuration”** menus can be protected by PIN code. See the **iDialog** software documentation ref 351910.

4.6.2 Stopping the transmitter

1

To fully stop the transmitter, press the emergency stop palm switch.

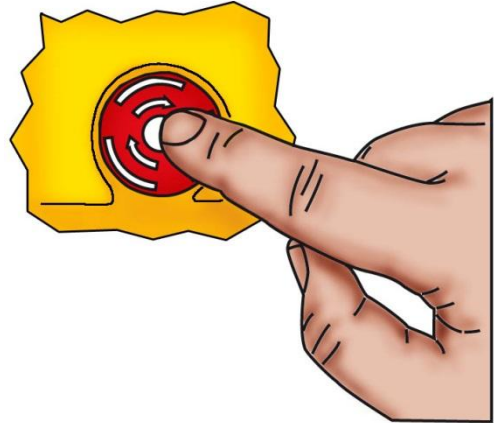

2

Before shutting down, the transmitter generates an “active” priority stop command to the Receiver (active stop).

To reactivate the transmitter after the emergency stop palm switch has been pressed, perform the “Startup” procedure detailed in the previous section.

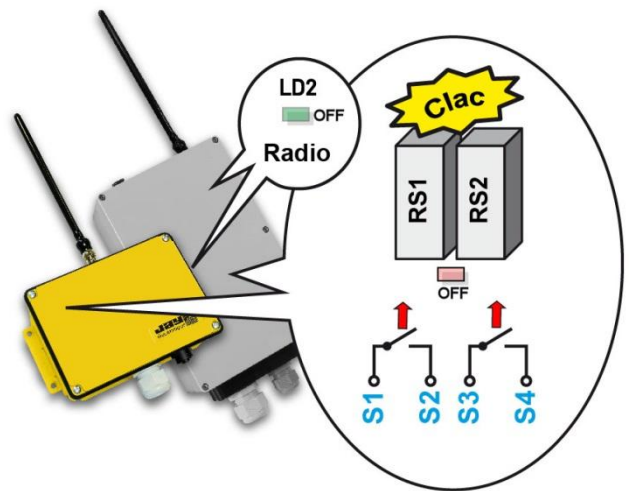

Note: The transmitter can also be stopped by the « **Standby Mode** » and « **Deadman** » (optional) functions detailed in the section “**Transmitter automatic stop function**”.

4.6.3 Function selector

Depending on the applications and utilisation needs, certain pushbuttons on the transmitter are configured to operate as function “**selectors**”.

Depending on the transmitter, up to 6 selectors can be implemented.

When a pushbutton on the transmitter is used in « selector » mode, the function is the function shown on the screen in the “selection designation” areas.

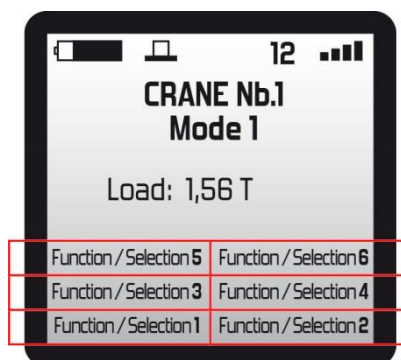

Each time the “selector” pushbutton is pressed and released, the screen displays the next function and transmits it to the Receiver.

Example:

Pushbuttons **F1** and **F2** of a transmitter have been configured in selector mode. Below is the operating principle when pushbutton **F2** is pressed (sequential lighting control):

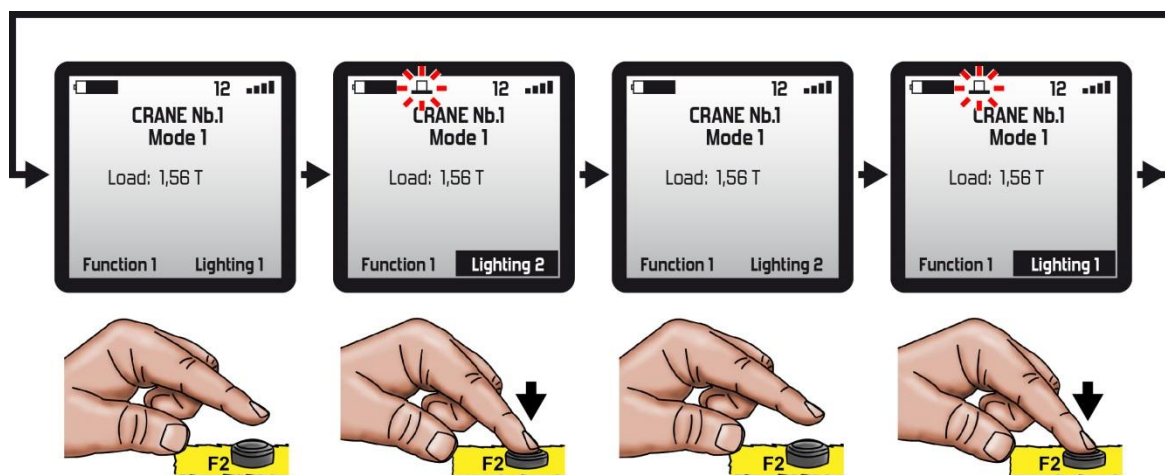

Note: The pushbuttons configured as selectors and the correspondence with the designation areas are indicated on the **configuration sheet** supplied with the radio control system.

Note: The function and selection designations can be modified using the **iDialog** configuration software.

4.7 Predefined alert messages

While using the transmitter, alert messages or pictograms can appear on the screen. These messages are displayed to inform you on a given situation and to guide you in certain cases to re-establish operation.

Depending on the "hardware" options of the product, it is possible to activate a vibrator device or a buzzer when the alert message appears on the transmitter screen (activation is done with the **iDialog** programming software).

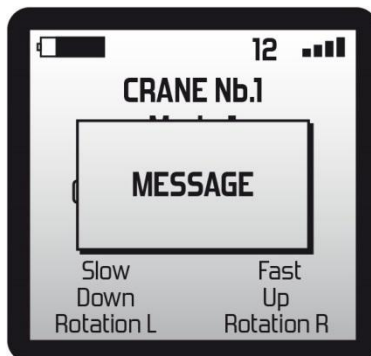

List of messages:

Message or pictogram	Description	Display time
	The standby function is going to be activated since the transmitter has not been used over a certain period of time.	Momentary. This message appears for 30 seconds before automatic shutdown of the transmitter
	The battery level is low. The battery must be recharged or replaced.	Momentary. This message appears several times before shutdown of the transmitter (battery discharged).
	The Receiver is in "safety" mode. The safety relays have been deactivated.	Permanent, up to reactivation of the Receiver (by pressing the "On" button on the transmitter).
	A change of parameter could not be synchronised with the Receiver (not acknowledged).	Momentary.
	Low radio link level between transmitter and receiver	Momentary
	A fault has been detected on actuation of a control component	Each time the concerned control component is actuated
	Dead man function Pre-alarm: This message indicates that the system will be put into "safety" mode if no control component is activated (or previously defined Dead man button)	Momentary (adjustable with iDialog software)
	The transmitter parameters saved in the Receiver memory differ from those saved in the transmitter memory.	Permanent, when starting the transmitter (the application's data must be reprogrammed into the memory of the receiver and / or the transmitter)
	Changing the mode is not possible because a control component is activated (button pressed, joystick handled etc ...)	As long as a control component remains activated

- Note 1:** All of the alarm messages can be cleared by pressing the "On" button  on the transmitter.
- Note 2:** 8 alert messages are available for the application. They can be configured with the **iDialog** programming software.







4.8 Configuration menu

The “**configuration**” menu is used to access the various configurations of the transmitter and of the radio control system.

IMPORTANT: Certain settings require shutdown of the Receiver.

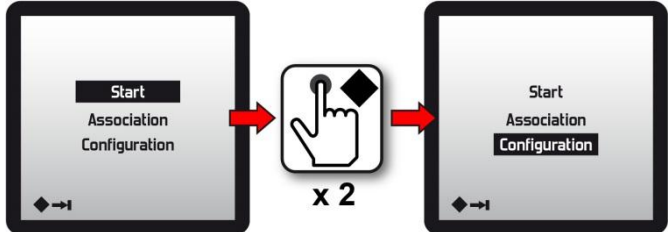
4.8.1 Accessing the configuration menu

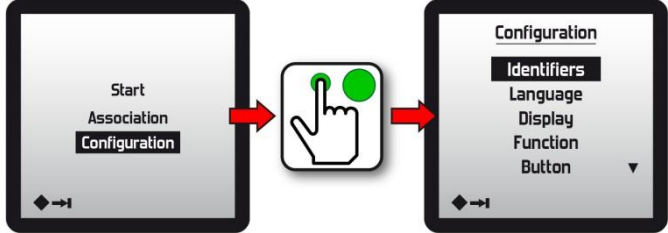
The “**configuration**” menu is accessible on power up of the transmitter:

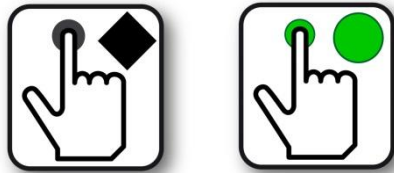
1	Switch on the transmitter	
2	Press the black “Tab” pushbutton  and select the “ Configuration ” menu on the home screen.	
3	Press the green validate pushbutton  to enter the configuration menu.	
4	The choice of parameters to be modified or reviewed is accessible by navigating using the black “Tab” navigation pushbutton  and the green validate pushbutton  .	

4.8.2 Configuration menu summary

The following menus are accessed from the “**configuration**” menu:

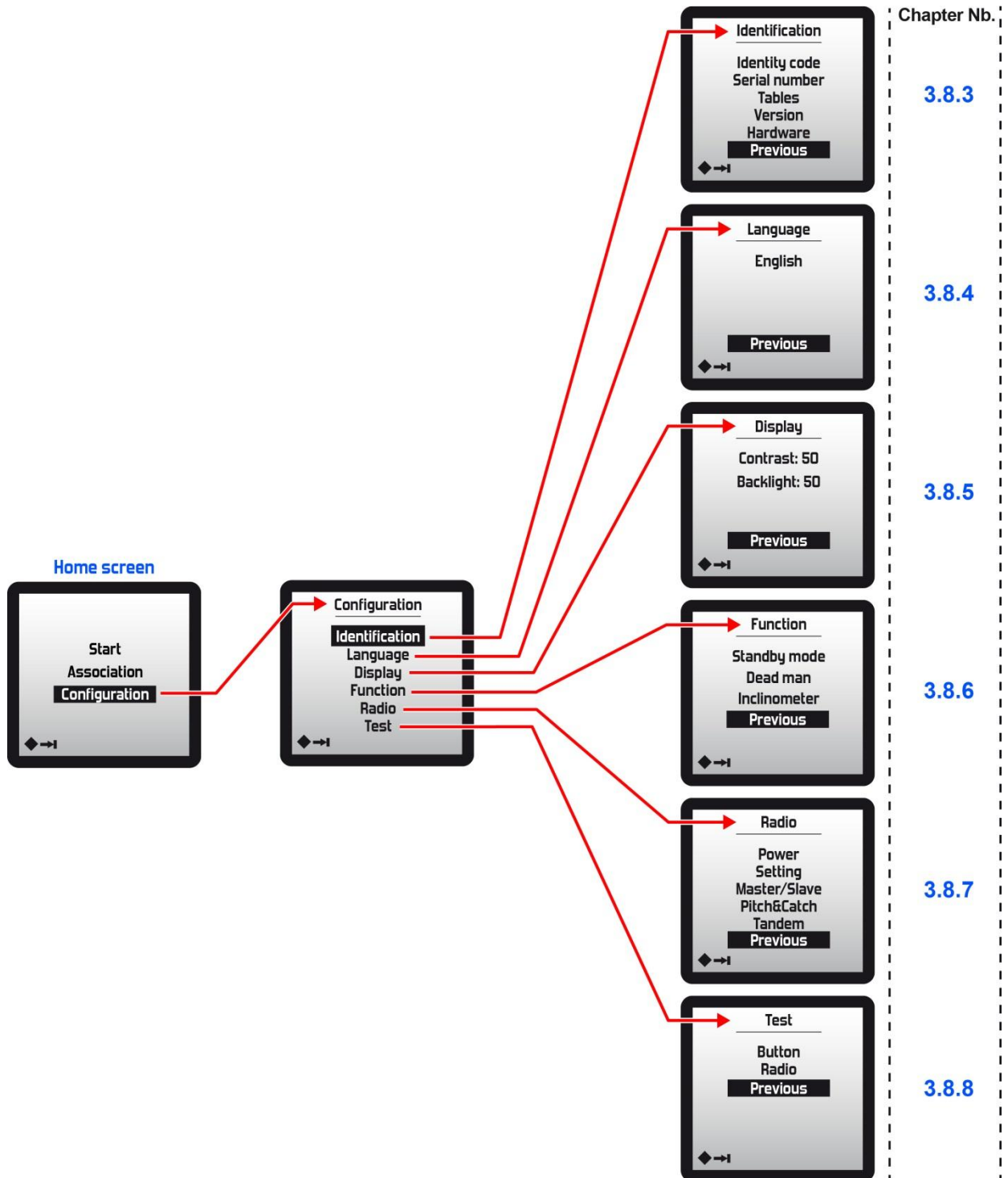

4.8.3 “Identification” menu

The “**Identification**” menu is used to display certain information of the radio control system such as:

- The **identity codes** of the radio control system,
- The **serial numbers** of Transmitter and associated Receiver,
- The **software version** of the Transmitter,

Note: These data can only be viewed (not modifiable).

4.8.3.1 Identity codes

The identity codes of the radio control system are formed by 5 digits; they are used to link a Transmitter to a Receiver.

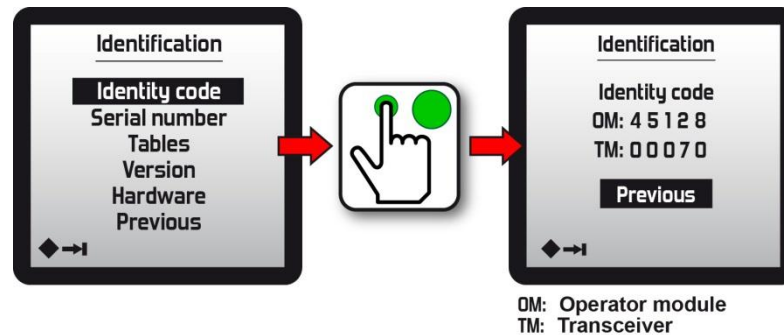

4.8.3.2 Serial numbers

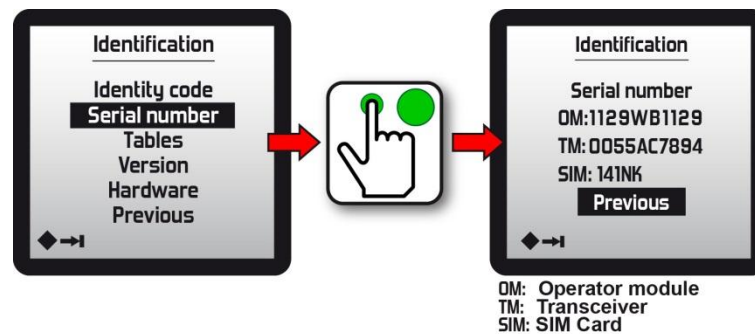

4.8.3.3 Tables

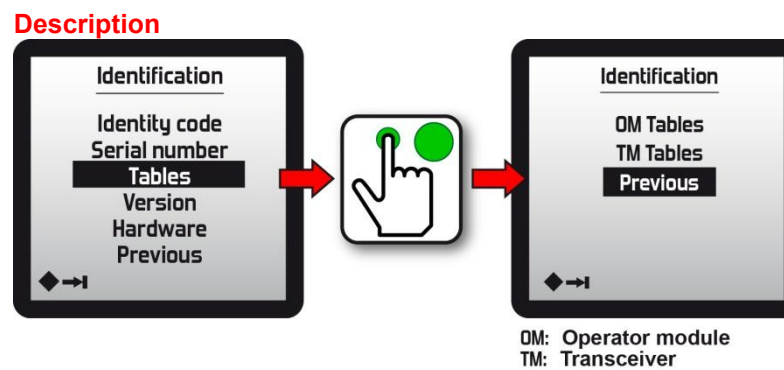

4.8.3.4 Software version of the Transmitter

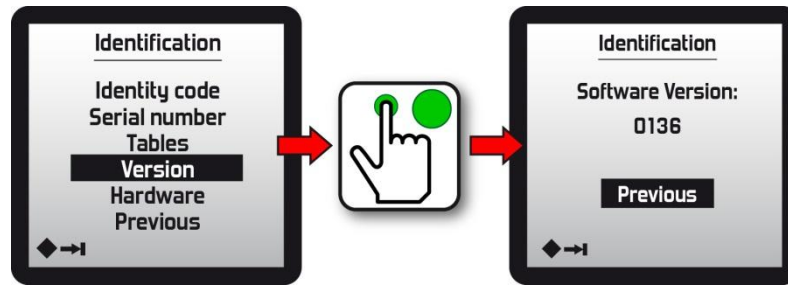

4.8.3.5 Hardware

List of options implemented in the transmitter and various related technical data.

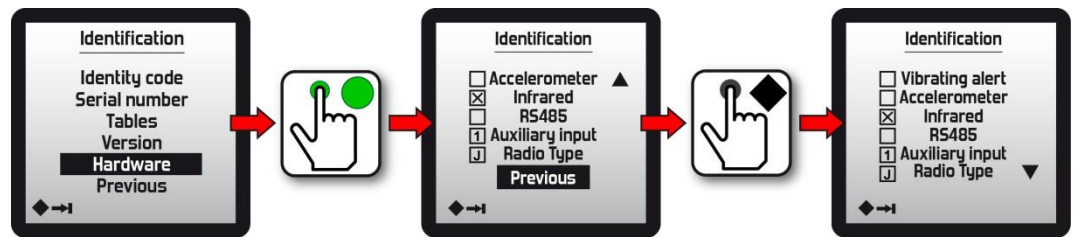





4.8.4 “Language” menu

This menu is used to change the language used by the Transmitter screen.

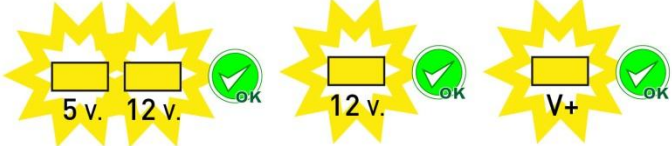
The following languages are available: **French, English, German, Spanish, Italian, Chinese, Dutch, Russian, Kazakh** (non exhaustive list).

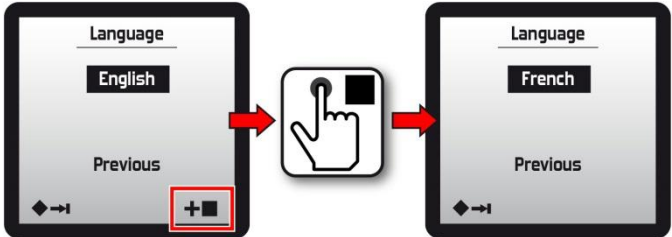
IMPORTANT: The **Receiver** must be **switched on** to change the language.

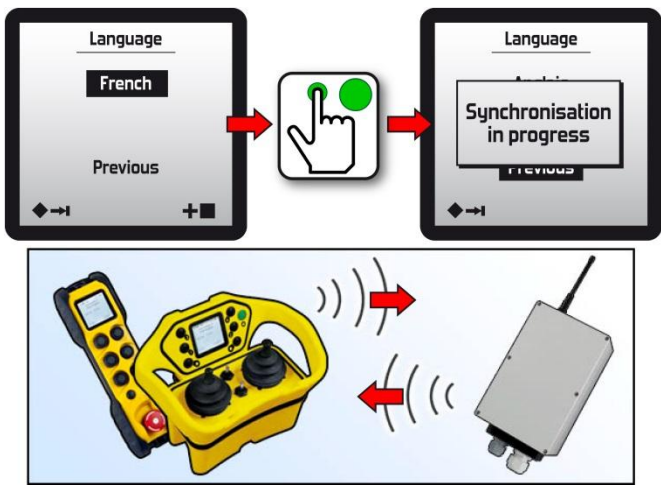
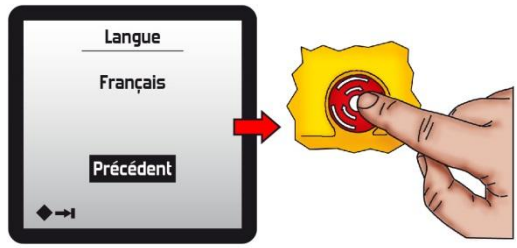
<p>1</p>	<p>Switch on the Receiver</p>	<p style="text-align: center;">Alto Elio Timo/Nemo</p> 
<p>2</p>	<p>Select the current menus language using the “Tab” navigation button .</p> <p>Change the language selection using the black “Increment” pushbutton .</p>	
<p>3</p>	<p>Once you have chosen the new language, press the green validate pushbutton .</p> <p>The Transmitter will transmit, by radio, the language configuration change to the Receiver (Synchronisation in progress message)</p>	
<p>4</p>	<p>Once the data synchronisation is completed, press the emergency stop palmswitch.</p> <p>The next time you start up the transmitter, the new language will be displayed on the screen.</p>	



4.8.5 “Display” menu

The “**Display**” menu is used to set the screen parameters, such as:

- The **contrast**,
- The **backlighting**,



4.8.5.1 Contrast

Note: The screen contrast can be set between **40** and **99**.

1	<p>Select the contrast value using the “Tab” navigation button .</p> <p>Change the value using the black “Increment” pushbutton . Each time you press this button, the digit selected is incremented.</p>	
2	<p>Once you have selected the desired value, press the green validate pushbutton . The Transmitter saves and applies the setting.</p>	

4.8.5.2 Backlighting

Note: The screen backlighting can be set between **00** (deactivated) and **99**.

1	<p>Select the backlighting value using the “Tab” navigation button .</p> <p>Change the value using the black “Increment” pushbutton . Each time you press this button, the digit selected is incremented.</p>	
2	<p>Once you have selected the desired value, press the green validate pushbutton . The Transmitter saves and applies the setting.</p>	

4.8.6 “Function” menu









This menu is used to configure and activate certain Transmitter functions.

The function activated by default is: “**Standby Mode**” (This function is described in the section “[Automatic stop functions](#)”).

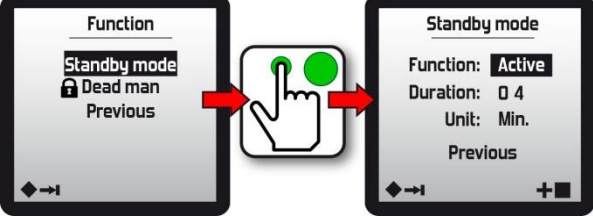
IMPORTANT: The **Receiver** must be **powered up** in order to modify the function settings.

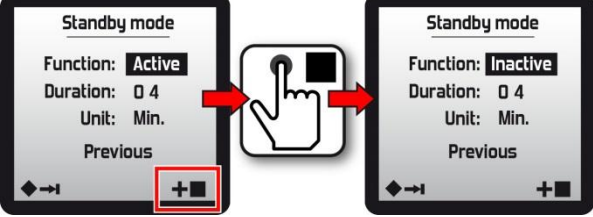
4.8.6.1 Standby

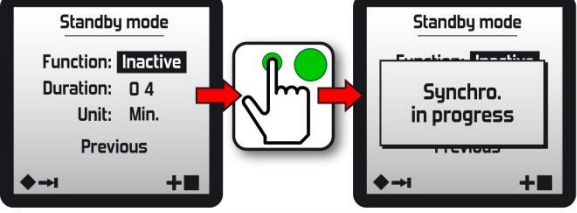
Note: The timeout prior to automatic stopping initiated by the **Standby Mode** function can be configured between **01** and **60** minutes. This function is activated by default.

<p>1</p>	<p>Switch on the Receiver.</p>	<p>Alto Elio Timo/Nemo</p> 
<p>2</p>	<p>In the "Function" menu, select the “Standby mode” function using the “Tab” navigation button . Validate your choice using the “Validate” button .</p>	
<p>3</p>	<p>Select the parameter to be changed using the « Tab » navigation button . Change the value using the black “Increment” pushbutton . Each time you press this button, the status of the selected field is modified or the selected digit is incremented.</p>	
<p>4</p>	<p>Once you have modified the parameters, press the green validate pushbutton . The Transmitter will transmit, by radio, the configuration change to the Receiver (Synchronisation in progress message).</p>	 

4.8.6.2 Dead man

See chapter *[“Deadman” function.](#)*

4.8.6.3 Inclinometer

See chapter *[“Inclinometer” function.](#)*

4.8.7 “Radio” menu

This menu is used to review and configure the radio characteristics of the radio control system.

IMPORTANT: The **Receiver** must be:

- Powered on,
- Paired with the transmitter,
- And available to perform the settings.

4.8.7.1 Power







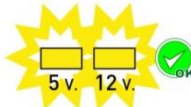

This menu is used to modify:

- The **radio emission power level of the Transmitter**,
- The **radio emission power level of the Receiver**

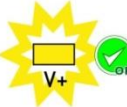
The radio emission power level can be adjusted to limit the radio control zone as may be required in certain cases.

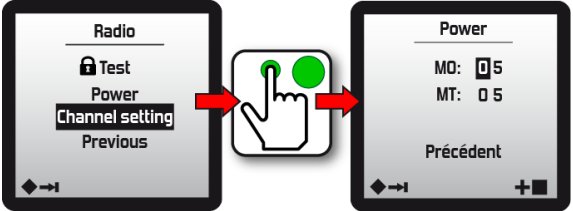
The radio emission power can be adjusted between **01** and 15 depending on the frequency range (see table on pages 126 to 128).

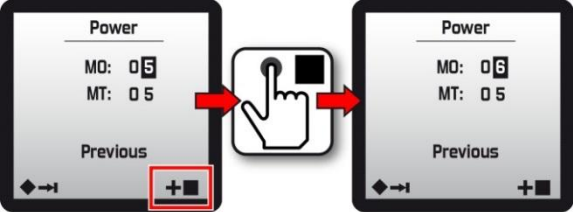
Warning !: Too low a value will significantly impact the transmit range; you must keep in mind the working distance between the Transmitter and the Receiver with respect to your needs.

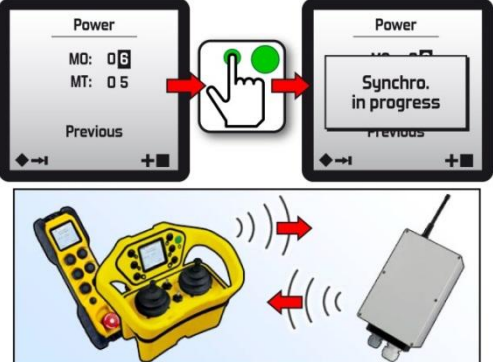
1	Switch on the Receiver.	<div style="display: flex; justify-content: space-around; align-items: center;"> <div style="text-align: center;"> <p>Alto</p>  </div> <div style="text-align: center;"> <p>Elio</p>  </div> <div style="text-align: center;"> <p>Timo/Nemo</p>  </div> </div>
2	In the “Radio” menu, select the “Power” sub-menu using the “Tab” navigation button  Validate your choice using the “Validate” button  .	
3	Select the parameter to be modified using the “Tab” navigation button  Modify the value using the black “Increment” pushbutton  Each time you press this button, the selected digit is incremented.	 <p style="text-align: center; font-size: small;">MO: Operator module MT: Transceiver</p>
4	Once the parameters have been modified, press the green validate pushbutton  The Transmitter will transmit, by radio, the change of radio power to the Receiver (Synchronisation in progress message).	







4.8.7.2 Setting the radio channel

This menu is used to configure:

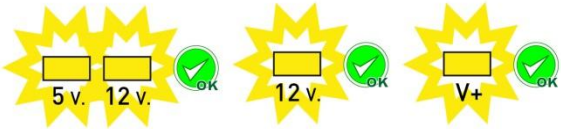
- The **radio emission mode** of the radio control system,
- The **number of the radio channel** used in the frequency band.

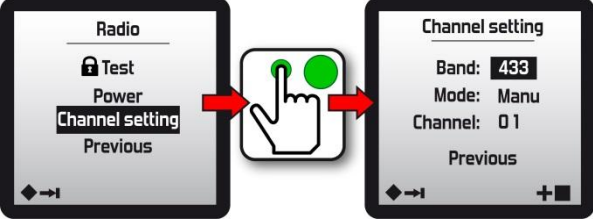
Frequency band	419: 419MHz (11 radio channels available)
	433: 433-434MHz (64 radio channels available)
	869: 869MHz (12 radio channels available)
	911: 911-918MHz (64 radio channels available)
	2.4: 2.4GHz (64 radio channels available)
Radio emission mode	Auto: <i>Automatic mode</i> At startup, the transmitter searches for the Receiver if it is not present on the current channel.
	Manu: <i>Manual Mode</i> The radio channel can be manually defined for the radio control system.
Radio channel	01 to 11 in 419MHz frequency band.
	01 to 64 in 433-434MHz frequency bands.
	01 to 12 in 869MHz frequency band.
	01 to 64 in 911-918MHz frequency bands.
	01 to 64 in 2.4 GHz frequency bands
Baudrate	It is recommended to use baudrate 4 when WHC is enabled. Caution: Using baudrate 4 restricts the number of available channels

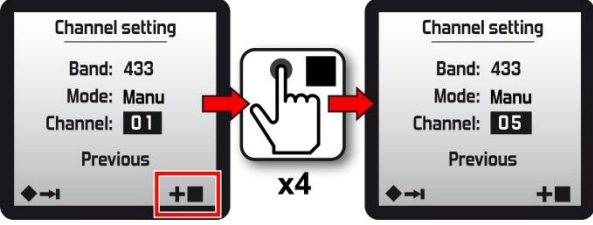
Procedure:

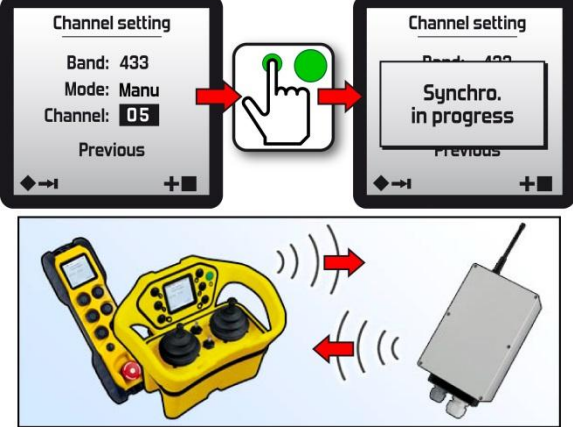
<p>1</p>	<p>Switch on the Receiver.</p>	<p>Alto Elio Timo/Nemo</p> 
<p>2</p>	<p>In the “Radio” menu, select the “Set channel” sub-menu using the “Tab” navigation button .</p> <p>Validate your choice using the “Validate” button .</p>	
<p>3</p>	<p>Select the parameter to be modified using the “Tab” navigation button .</p> <p>Modify the value using the black “Increment” pushbutton . Each time you press the button, the status of the selected field is changed or the selected digit is incremented.</p>	
<p>4</p>	<p>Once you have modified the parameters, press the green validate pushbutton .</p> <p>The Transmitter will transmit, by radio, the changes to the Receiver (Synchronisation in progress message).</p>	

4.8.7.3 List of available radio frequencies

419 MHz band		433-434 MHz bands				869 MHz band		911-918 MHz bands ⁽¹⁾				2,4 GHz bands			
Channel No.	Frequency MHz	Channel No.	Frequency MHz	Channel No.	Frequency MHz	Channel No.	Frequency MHz	Channel No.	Frequency MHz	Channel No.	Frequency MHz	Channel No.	Frequency MHz	Channel No.	Frequency MHz
01	418,975	01	433,1025	33	433,9025	01	869,9875	01	911,800	33	915,100	01	2402,00	33	2442,00
02	419,000	02	433,1275	34	433,9275	02	869,9625	02	911,900	34	915,200	02	2403,25	34	2443,25
03	419,025	03	433,1525	35	433,9525	03	869,9375	03	912,000	35	915,300	03	2404,50	35	2444,50
04	419,050	04	433,1775	36	433,9775	04	869,9125	04	912,100	36	915,400	04	2405,75	36	2445,75
05	419,075	05	433,2025	37	434,0025	05	869,8875	05	912,200	37	915,500	05	2407,00	37	2447,00
06	419,100	06	433,2275	38	434,0275	06	869,8625	06	912,300	38	915,600	06	2408,25	38	2448,25
07	419,125	07	433,2525	39	434,0525	07	869,8375	07	912,400	39	915,700	07	2409,50	39	2449,50
08	419,150	08	433,2775	40	434,0775	08	869,8125	08	912,500	40	915,800	08	2410,75	40	2450,75
09	419,175	09	433,3025	41	434,1025	09	869,7875	09	912,600	41	915,900	09	2412,00	41	2452,00
10	419,200	10	433,3275	42	434,1275	10	869,7625	10	912,700	42	916,000	10	2413,25	42	2453,25
11	419,250	11	433,3525	43	434,1525	11	869,7375	11	912,800	43	916,100	11	2414,50	43	2454,50
		12	433,3775	44	434,1775	12	869,7125	12	912,900	44	916,200	12	2415,75	44	2455,75
		13	433,4025	45	434,2025			13	913,000	45	916,300	13	2417,00	45	2457,00
		14	433,4275	46	434,2275			14	913,100	46	916,400	14	2418,25	46	2458,25
		15	433,4525	47	434,2525			15	913,200	47	916,500	15	2419,50	47	2459,50
		16	433,4775	48	434,2775			16	913,300	48	916,600	16	2420,75	48	2460,75
		17	433,5025	49	434,3025			17	913,400	49	916,700	17	2422,00	49	2462,00
		18	433,5275	50	434,3275			18	913,500	50	916,800	18	2423,25	50	2463,25
		19	433,5525	51	434,3525			19	913,600	51	916,900	19	2424,50	51	2464,50
		20	433,5775	52	434,3775			20	913,700	52	917,000	20	2425,75	52	2465,75
		21	433,6025	53	434,4025			21	913,800	53	917,100	21	2427,00	53	2467,00
		22	433,6275	54	434,4275			22	913,900	54	917,200	22	2428,25	54	2468,25
		23	433,6525	55	434,4525			23	914,000	55	917,300	23	2429,50	55	2469,50
		24	433,6775	56	434,4775			24	914,100	56	917,400	24	2430,75	56	2470,75
		25	433,7025	57	434,5025			25	914,300	57	917,500	25	2432,00	57	2472,00
		26	433,7275	58	434,5275			26	914,400	58	917,600	26	2433,25	58	2473,25
		27	433,7525	59	434,5525			27	914,500	59	917,700	27	2434,50	59	2474,50
		28	433,7775	60	434,5775			28	914,600	60	917,800	28	2435,75	60	2475,75
		29	433,8025	61	434,6025			29	914,700	61	917,900	29	2437,00	61	2477,00
		30	433,8275	62	434,6275			30	914,800	62	918,000	30	2438,25	62	2478,25
		31	433,8525	63	434,6525			31	914,900	63	918,100	31	2439,50	63	2479,50
		32	433,8775	64	434,6775			32	915,000	64	918,200	32	2440,75	64	2480,75

(1) Warning! For Australia, in the 915 MHz band, only channels 32 (915 MHz) to 64 (918,2 MHz) can be used.

4.8.7.4 Tandem

See chapter [“Tandem synchronised command” function.](#)

4.8.7.5 Master – Master

See chapter [“Master – Master synchronised command” function.](#)

4.8.7.6 Pitch & Catch 2.0

See chapter [“Pitch & Catch 2.0” function.](#)

4.8.7.7 Pick & Control 2.0

See chapter [“Pick & Control 2.0” function.](#)

4.8.7.8 MultiDevices

See chapter [“MultiDevices” function.](#)

4.8.8 Test

4.8.8.1 Channel scan

This function allows you to quickly identify the free channels and the occupied channels, which then allows you to configure the frequency of your transmitter / receiver unit on an undisturbed channel. In order for this test to be most effective, it is imperative to perform the test at the location where the antenna of the receiver will be installed.

Procedure:

In the “Configuration” menu, select function “Test” with navigation button “Tabulation”  and valid choice with “Validation”  button, and select “Channel Scan” function

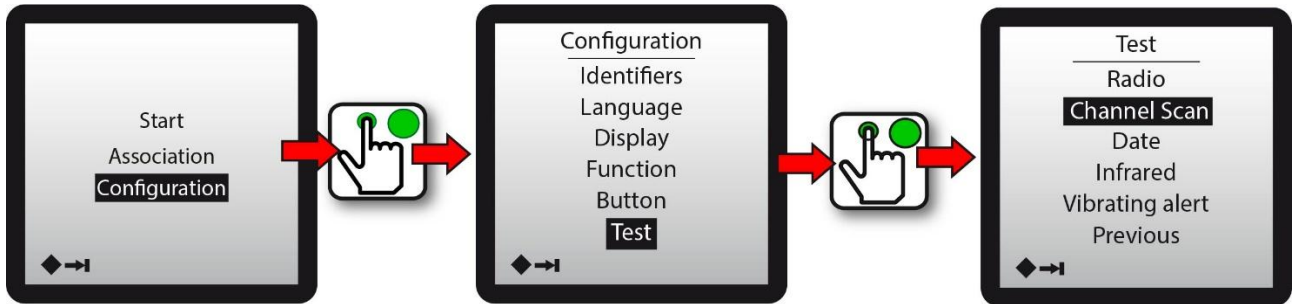

After scanning the entire frequency band, the screen displays a graph with 2 levels of information:

- 1- In black, the maximum band occupancy over the last 5 seconds
- 2- In hatched, the maximum band occupancy since the function was activated. So, you can measure for a long time and see intermittent disturbances.

Attention, this function does not replace a spectrum analyzer as the channels are scanned sequentially. A very short disturbance may not be seen.

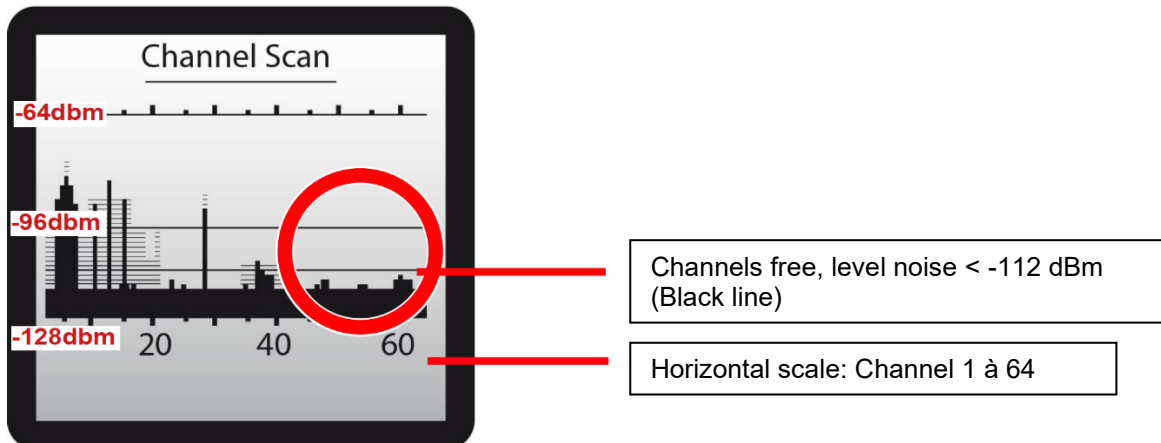

4.9 Transmitter automatic stop functions

4.9.1 Standby mode

The transmitter is equipped, as a standard function, with the “**Standby mode**” automatic stop function; this function is linked to the control components.

Operating principle:

The “**Standby mode**” function is activated when the control components of the transmitter have not been used over a (programmable) period of time.

10 seconds before activation of the “**Standby mode**” function, the transmitter displays the following screen:

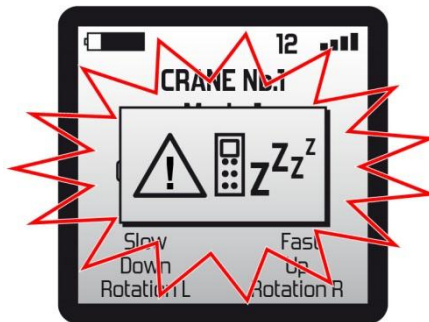

If no action is performed on the control components (pushbuttons) within 30 seconds, the transmitter stops and deactivates the safety relays RS1 and RS2 of the Receiver.

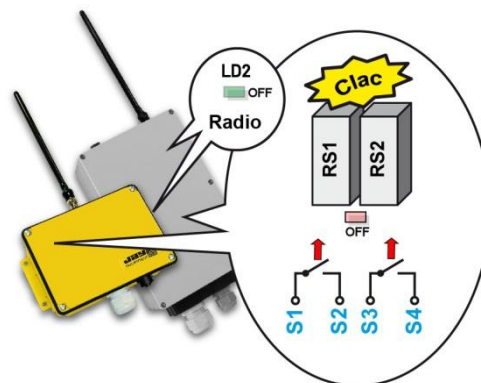

To restart the system, press the "On" button  on the transmitter.



Configuration:

The standby mode function time delay can be configured between 01 and 60 minutes.

This function can be activated or deactivated; see section [Configuration menu / Function menu](#).

4.9.2 "Deadman"

This function is actuated when the control components have not changed position over a (programmable) period of time.

This function can also be associated with a movement sensor, with each detection resetting the programmed duration to zero.

4.10 Default configuration of transmitter

Language of screen menus	Language specified on configuration sheet supplied with radio control system
Screen display	<ul style="list-style-type: none">• Contrast: 50• Backlighting: 50
"Standby mode" function	<ul style="list-style-type: none">• Function activated• Time delay before automatic stopping of transmitter: 4 minutes
Radio emission power	<ul style="list-style-type: none">• Transmitter: 08• Receiver: 08
Radio emission mode	Manual
Frequency band	419MHz or 433-434 or 869 or 911-918MHz bands or 2.4GHz (depends on equipment)
Number of radio channel used	Frequency with automatic assignment according to chart
Assignment of control components / receiver outputs	Per application configuration (see configuration sheet supplied with radio control system)
Command interlocking	Per application configuration (see configuration sheet supplied with radio control system)

5 Charger and Support chargers

5.1 WARNING concerning the battery

- THERE IS A RISK OF EXPLOSION IF BATTERY IS REPLACED BY A BATTERY OF AN INCORRECT TYPE. ONLY BATTERY PWB SUPPLIED BY JAY ELECTRONIQUE IS SUITABLE.
- ONLY THE JAY ELECTRONIQUE CHARGERS ARE SUITABLE FOR RECHARGING THE BATTERIES.
- DO NOT EXPOSE THE BATTERY TO TEMPERATURE ABOVE 50°C (122°F).
- DURING THE CHARGE THE TEMPERATURE MUST BE BETWEEN 10°C MINIMUM TO 40°C MAXIMUM.
- DO NOT OPEN OR ATTEMPT TO MODIFY THE BATTERY.
- FAILURE TO FOLLOW INSTRUCTIONS MAY CAUSE FIRE OR EXPLOSION.
- PLEASE RESPECT THE DISPOSE OF USED BATTERIES AS DIRECTED.

5.2 Information on battery storage

The transmitter battery must be stored charged with a minimum charging capacity of 40%. The storage must be in a clean and dry place at room temperature, and in all cases, in accordance with the temperatures specified in chapter [Technical characteristics / Transmitters](#).

Self-discharge is estimated at 10% in the first month and then lower (it is mandatory to recharge the battery every 9 months min.).





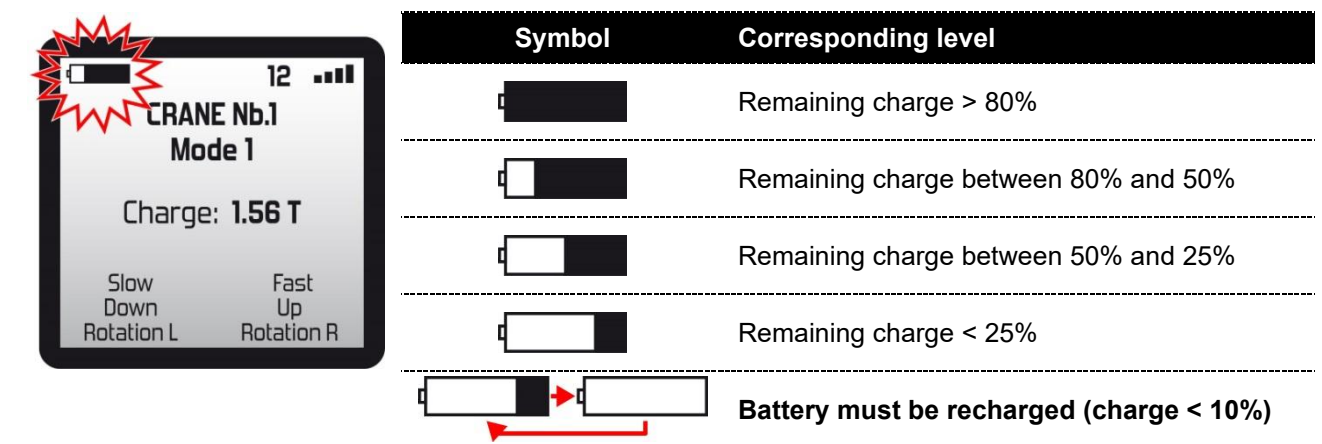











5.3 Transmitter battery: charge level

The charge level of the battery in the transmitter is displayed on the screen during use:



5.4 General view of charger and support chargers

Given below are the charger and support chargers to be used in accordance with your transmitter model:

Type of transmitter	Type of battery	Charger and support chargers
 <p>Gama 10+4</p>  <p>Gama 6+4</p>	<p>Plug-in type</p>  <p>PWB</p>	<p>For Gama 6+4</p>  <p>PWCG06+ UBCU</p> <p>For Gama 10+4</p>  <p>PWCG10+ UBCU</p> <p>For battery PWB</p>  <p>PWC UBCU</p>
 <p>Beta 6+4</p>	<p>Plug-in type</p>  <p>PWB</p>	<p>For Beta 6+4</p>  <p>PWCB06+ UBCU</p> <p>For battery PWB</p>  <p>PWC UBCU</p>
 <p>Beta 2+4</p>	<p>Internal battery</p>	 <p>PWCB02+ UBCU</p>
 <p>Pika</p>  <p>Moka</p>	<p>Plug-in type</p>  <p>PWB</p>	 <p>PWC UBCU</p>  <p>PWCPM01 PWCPM01 PWCPM01</p>





5.5 Information on battery charge

The charging time for an 80% battery charge is 3 h; beyond this time, the charger or support charger delivers a trickle charge.

A 20 min. charge represents around 1h of endurance.

The number of full charge cycles is estimated at 500 cycles min. (with no degradation of the battery).

When the transmitter is placed on a support charger (Gama or Beta), the charge level of the battery is indicated on the transmitter screen:

Symbol (flashing)	Corresponding level
	Start of battery charging Battery charged between 0% and 25%
	Battery charged between 25% and 50%
	Battery charged between 50% and 75%
	Charging complete

Remarque: Under low (negative) temperature operating conditions, you may observe an endurance loss of 20%. The transmitter is, however, equipped with an internal sensor which accurately indicates the remaining battery endurance regardless of the operating conditions.

5.6 Indicator light on charger and support chargers

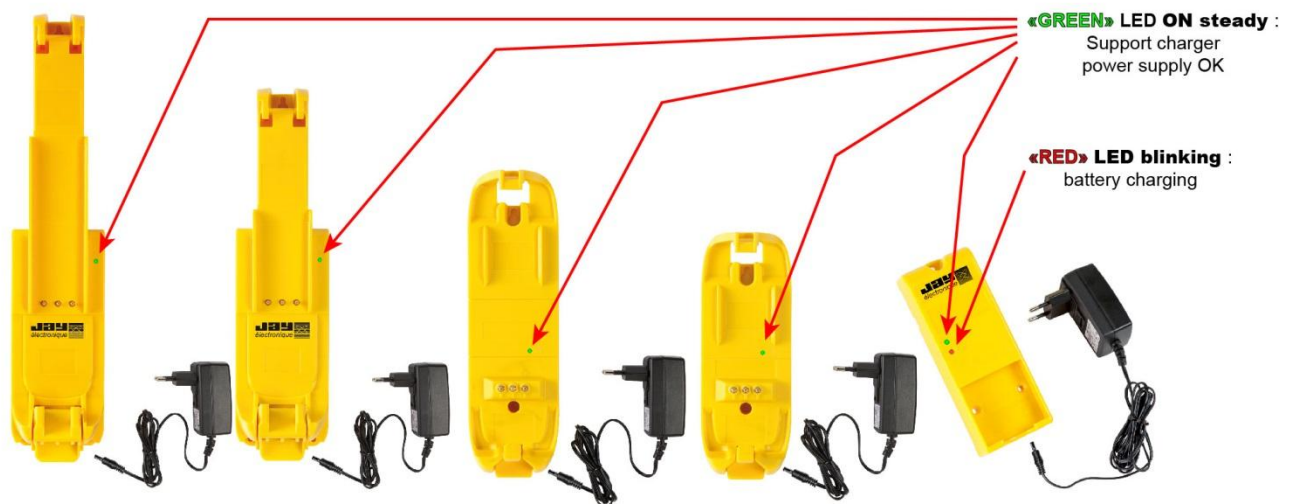

The red indicator light on the **PWC** charger gives information on the charge or a message in the event of a malfunction:

RED indicator light	GREEN indicator light	Indication
OFF	ON	Battery charge complete
ON	OFF	Temperature fault or no power supply
OFF	OFF	Charging fault (electronic malfunction)

5.7 Supply of chargers and support chargers

The chargers can be supplied in different ways as described below.

Note: The chargers must be opened to connect the power supply; a cover plate is provided for this purpose. Use a Pozidriv **PZ2** screwdriver.

5.7.1 Power supply by voltage adapter

Adapter ref.: **UBCU**

Manufacturer ref.: SK01G- 1200050Z (SIMSUKUIAN)

AC input: 100-240 Vac 50/60Hz

DC output: 12Vdc - 0.5A

Only this adapter shall be used with PWC

The adapter is connected to a supply plug inside the charger.

- 1- Remove the housing cover.
- 2- Connect the **UBCU** supply plug to the internal connector of the charger.
- 3- Close the housing, taking care not to pinch the cord.

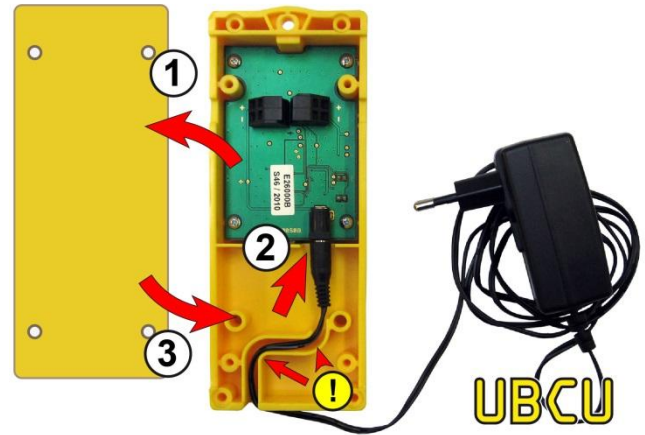

5.7.2 Power supply by external source

The power supply must provide a regulated, stabilised voltage of **12-24VDC 7W min - type PS1 (< 15W)**.

The power supply is connected on a terminal strip with 2 spring-type terminals inside the charger (wire section 0.08mm² to 2.5mm² max.)

- 1- Remove the housing cover.
- 2- Connect the wires of the external power supply to the internal terminal block.
- 3- Close the housing, taking care not to pinch the wires.

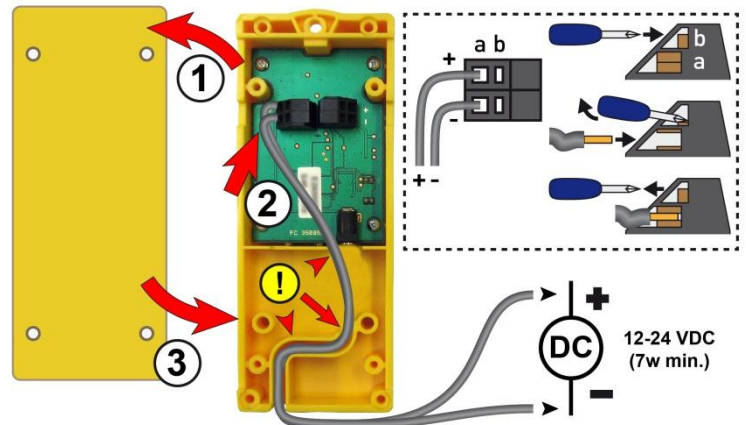

5.8 Options on chargers

5.8.1 Concerned models: PWCB021, PWCB061, PWCG061, PWCG101, PWCB022, PWCB062, PWCPM01

Chargers equipped with "all options" allow to detect and alert the user about the presence or absence of Transmitter on the support.

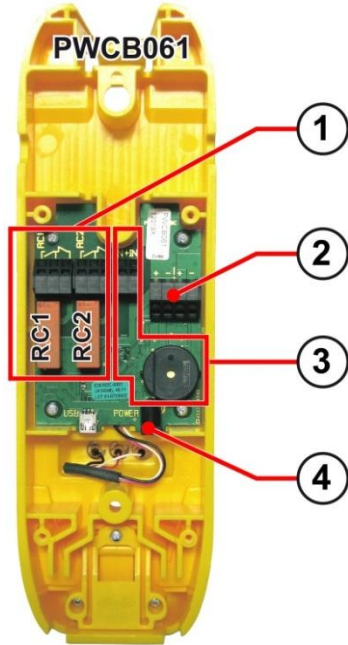

1	Relays RC1 and RC2: When the Transmitter is charging on the support charger, the relays RC1 and RC2 are activated (change-over contacts).
2	Connector for external power supply (regulated, stabilised voltage of 12-24VDC)
3	Internal Buzzer: When a voltage is applied into the digital input (terminals IN + and IN-) and the Transmitter is absent from the support charger, the internal buzzer is activated for 1 minute.
4	Supply plug for voltage adapters UBCU

Terminal block wiring

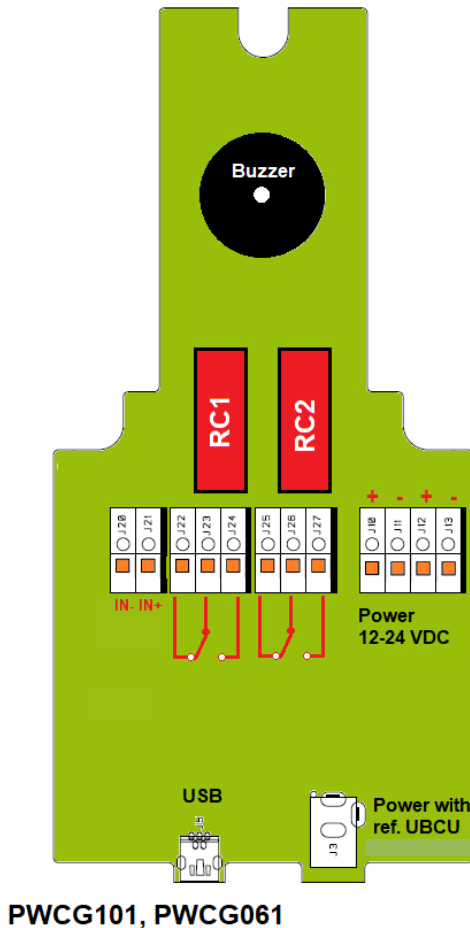

Relays RC1 and RC2 characteristics:

Contacts	AgNi 0,15
Maximum power at cosphi=1	2000 VA
Max. current / voltage switching	8 A / 400 VAC
Min. current / voltage advised switching	50 mA / 12 VDC
Switching cycles at 250 VAC, 8 A, cosphi=1	100 000
Switching cycles at 24 VDC, 8 A	50 000
Tests per EN 60947-5-1	DC13 at 0,5 A / 24 VDC
	AC15 at 3 A / 250VAC

(IN+, IN-) Digital input characteristics:

Low level on opto-coupler input	DC Voltage < 2 V
High level on opto-coupler input	DC Voltage > 3 V
Maximum voltage level on an input with no damage	30VDC

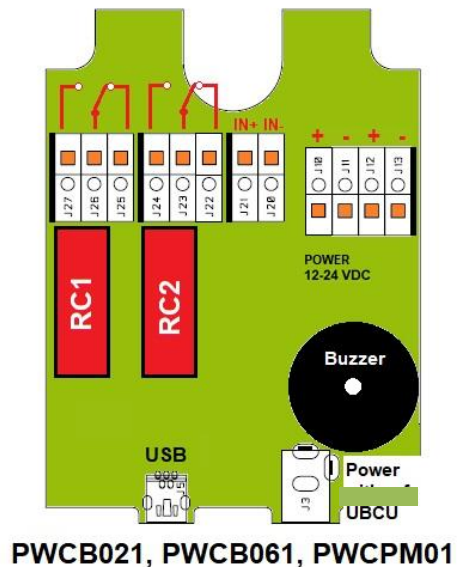

5.8.2 Concerned models: PWCB022, PWCB062

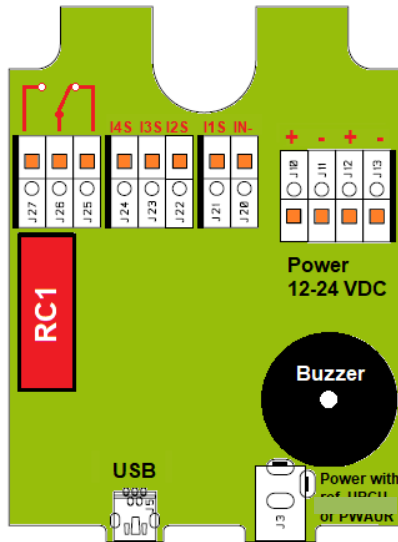

PWCB022, PWCB062

1	Relay RC1: When the transmitter is charging on the charger support, relay RC1 is activated (change-over contacts).
2	Connector for external power supply (regulated, stabilised voltage of 12-24VDC)
3	Internal Buzzer: When a voltage is applied into the digital input (terminals IN + and IN-) and the Transmitter is absent from the support charger, the internal buzzer is activated for 1 minute.
4	Supply plug for voltage adapters UBCU

5.8.3 Example of wiring for use of the "all options" load carrier on a vehicle:

If the transmitter is not present on the charger support when starting the vehicle, the internal buzzer of the charger support is activated for 1 minute and a warning light (ideally located in the cockpit of the vehicle).

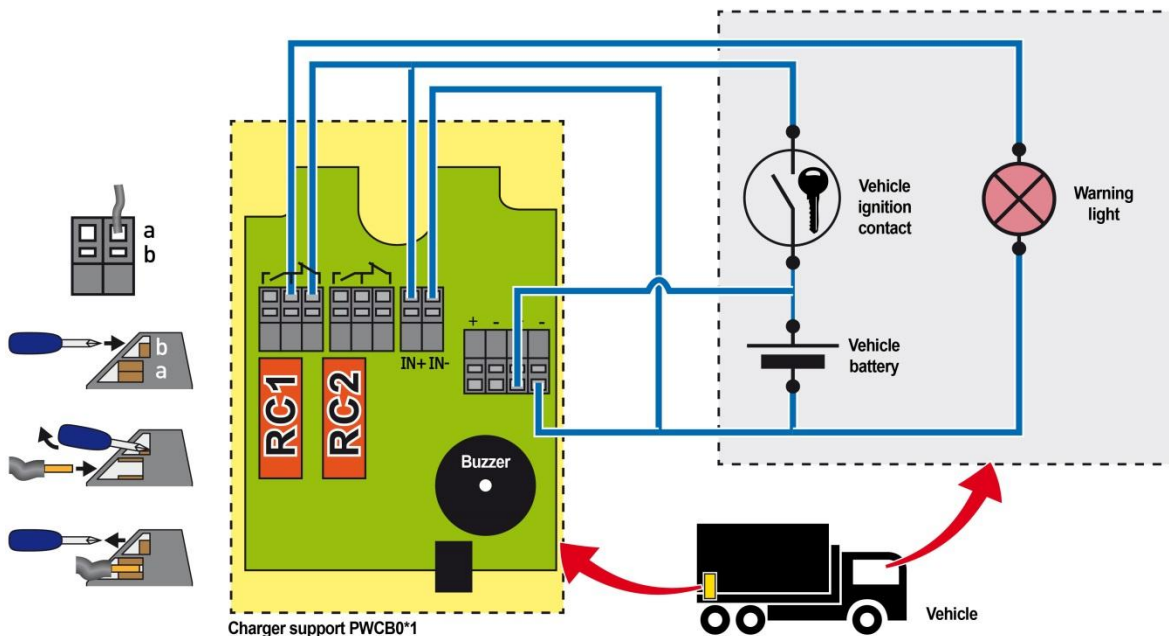

5.8.4 Mounting charger bracket PWCB021, PWCB061, PWCG061, PWCG101, PWCB022, PWCB062, PWCPM01

The support charger bracket is for use of wall or work plan.

Position the mounting charger bracket and fix it by means of two or three screws depends on model. The diameter of the fixed holes is 5mm for all models.

Secure the wall mounting charger bracket to the structure by using screws (not provided). Ensure that is solidly fixed.

Weight information

- PWCB021, PWCB022: 400 g.
- PWCB061, PWCB062: 500 g.
- PWCG061: 650 g.
- PWCG101: 800 g.

5.8.4.1 Attaching the support charger

➤ *BETA product*

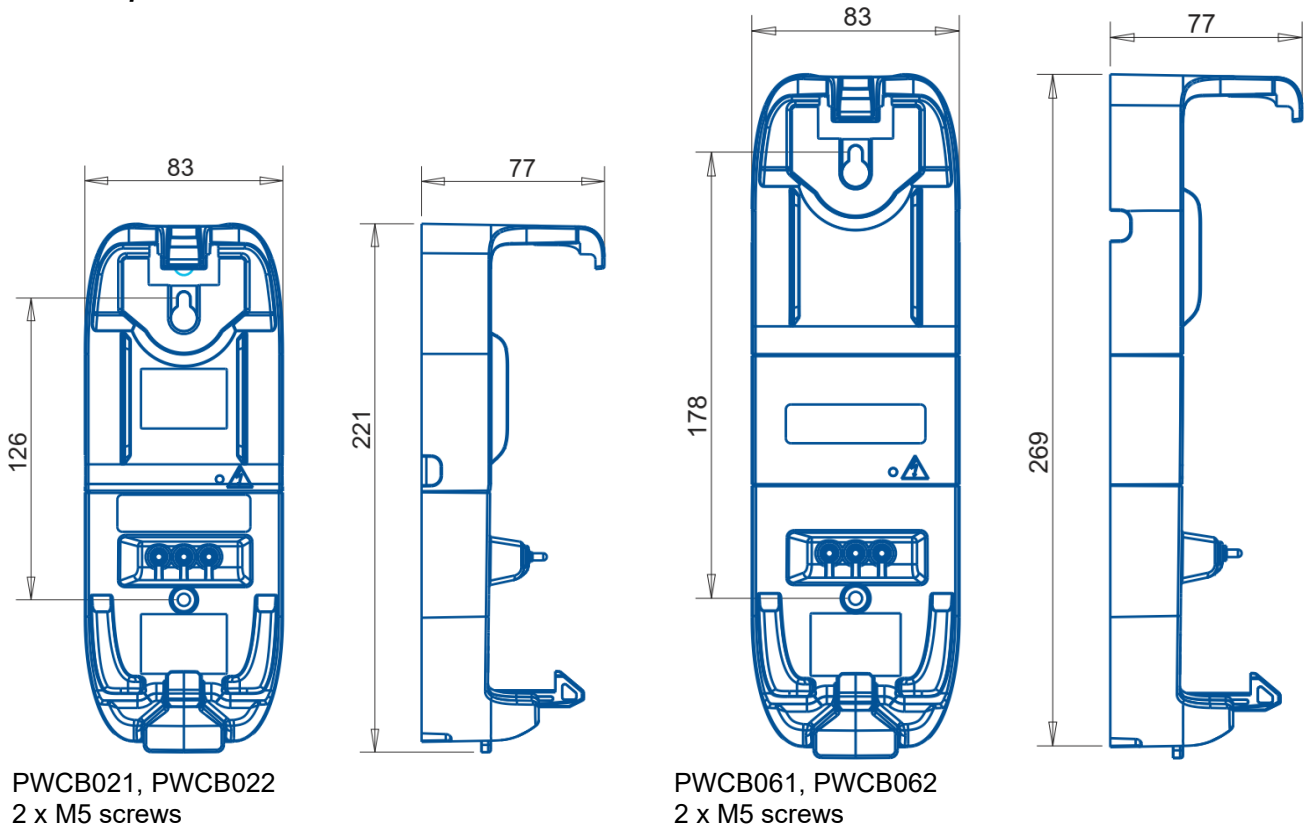

➤ **GAMA products**

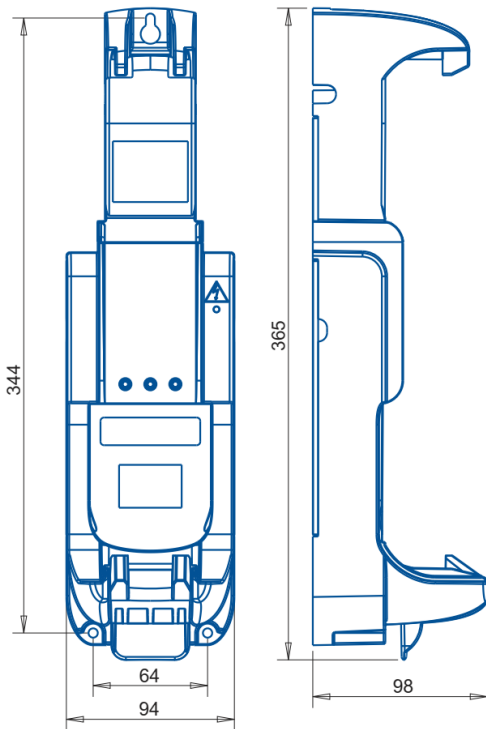

PWCG061
3 x M5 screws

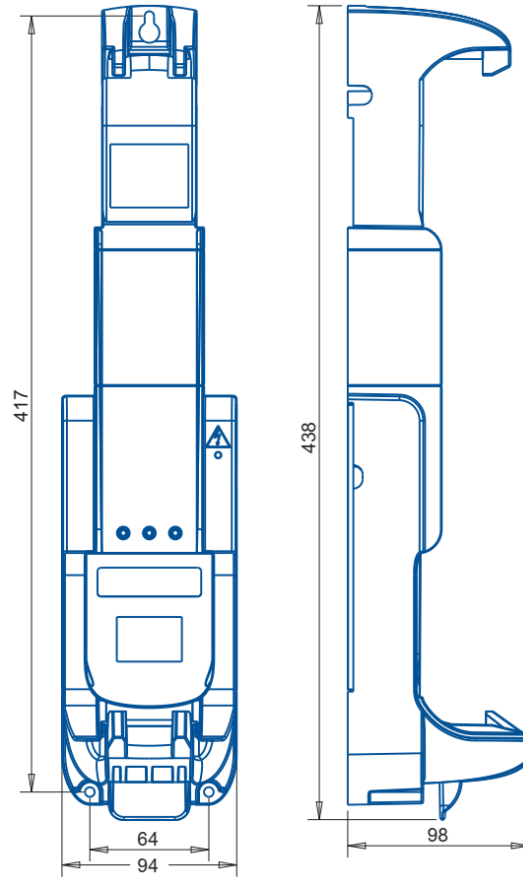

PWCG101
3 x M5 screws

5.8.5 Load and work support for PIKA or MOKA Manipulators: PWCPM01

The PIKA - MOKA charging cradle allows the transmitter to be recharged and stowed away. This means that the radio control unit is immobilised while its battery is being charged. The transmitter must be locked in its holder so that the charging contacts of the PIKA or MOKA are maintained despite shocks and vibrations. The charging cradle also allows the operator to work while charging the radio control.

5.8.5.1 Technical data

- IP65 tightness level
- Plastic material: ABS PC, flammability UL class V0
- Power supply: externally regulated and stabilised 12-24VDC or power plug for UBCU voltage adapter
- For interface of electronic board, it is same that charger support PWCB022 and PWCB062 refer to paragraph 5.8 Options on chargers.
- Weight: 1400 g.

5.8.5.2 Attaching the load support

- With 3 M5 screws for fixing on a horizontal plane.
- By 4 M5 screws for fixing on a vertical plane

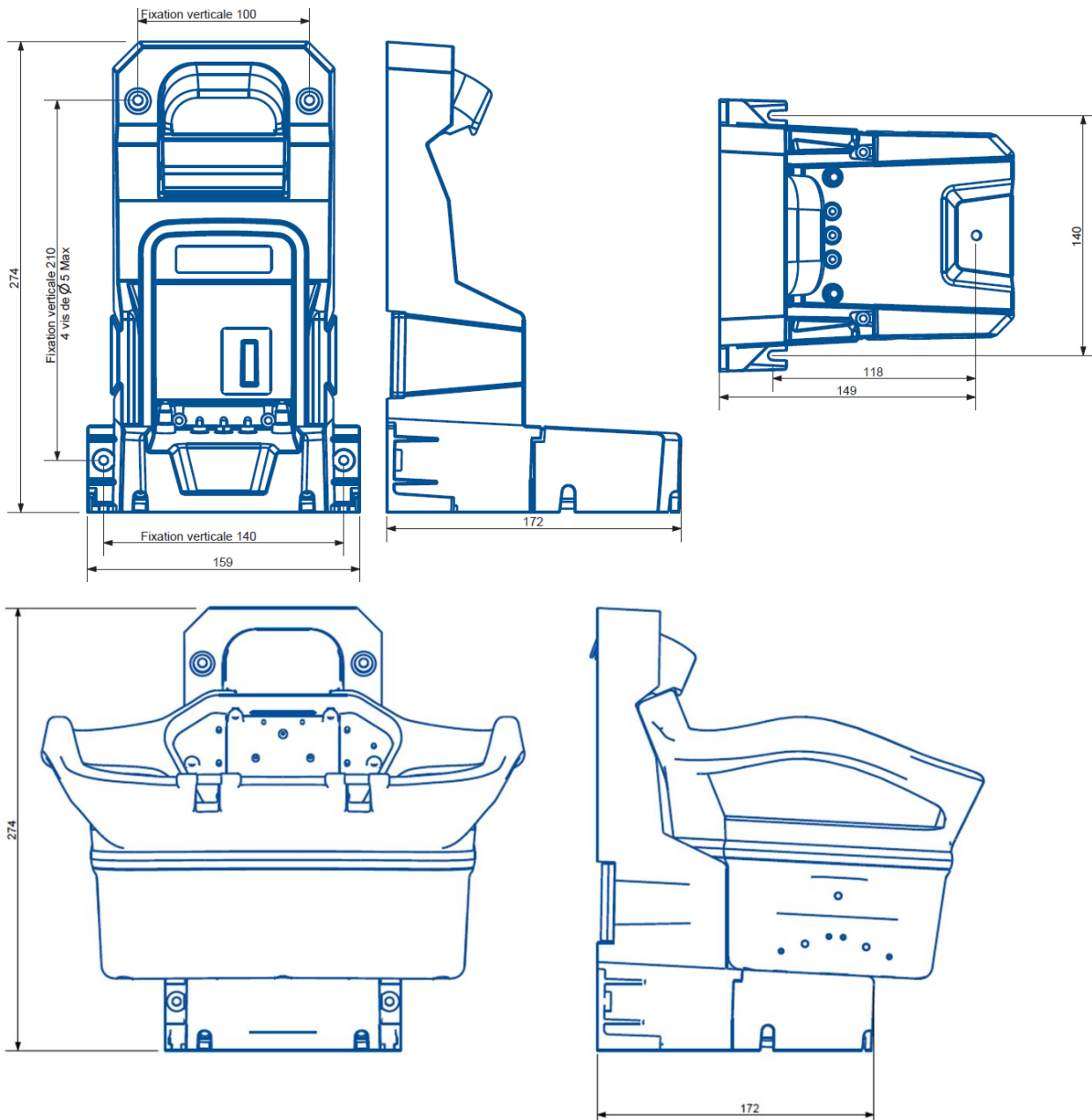

6 Receiver

6.1 General view of Receivers

6.1.1 Elio Receiver



TO AVOID ANY RISK OF ELECTROCUTION, NEVER OPEN THE TRANSCIEVER HOUSING WHICH IS POWERED UP.

The opening of the housing must be done by ensuring that the power supply cables and control cables are out of voltage

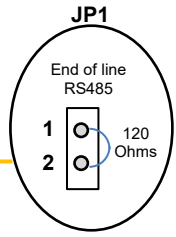
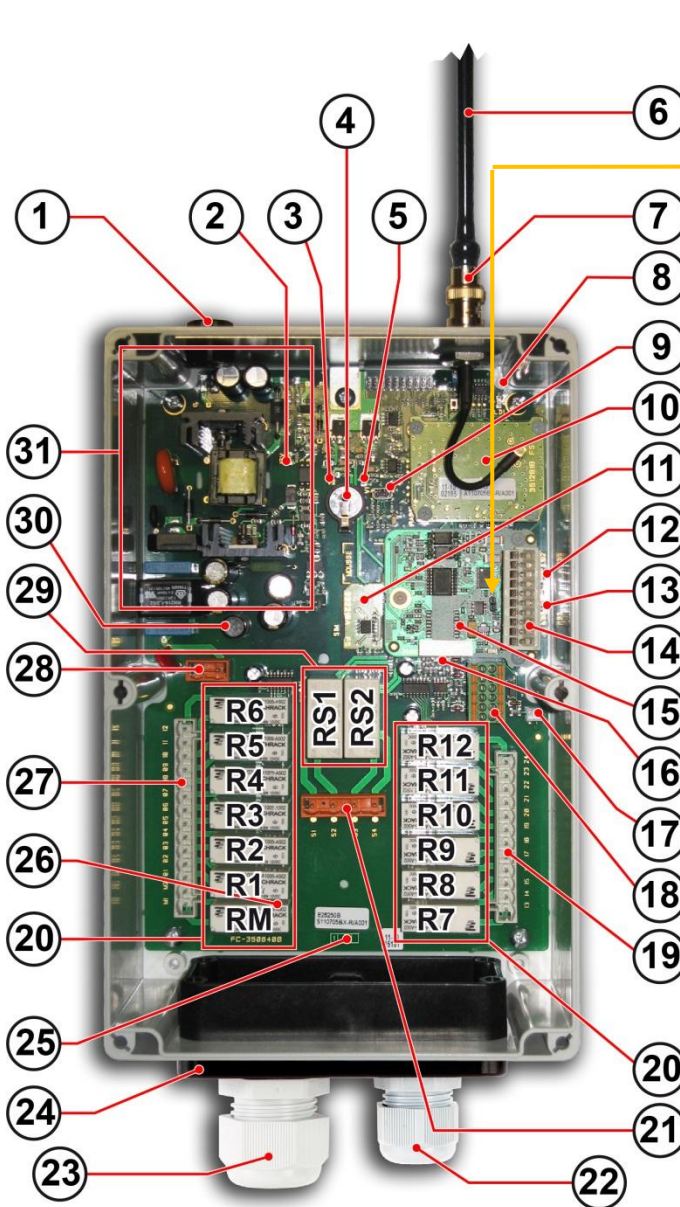

1	Breathable membrane (internal anti-condensation)
2	Yellow indicator light 12V : motherboard power supply OK
3	Yellow indicator light V2 : processor power supply No. 2 OK
4	Backup battery (daily time stamping of events)
5	Yellow indicator light V1 : processor power supply No. 1 OK
6	Antenna (BNC connection)
7	Antenna BNC / antenna extension connector
8	Red indicator light LD1 : Diagnostics
9	USB connector (configuration and diagnostics)
10	2-way radio module
11	SIM card (system configuration backup)
12	Green indicator light LD2 : Radio reception + Diagnostics
13	Red indicator light LD3 : Diagnostics
14	Input/output connector of extension board (option)
15	Extension board (analogue outputs, On/Off, RS485 etc.) (option)
16	Red indicator light: status of safety relays RS1 and RS2
17	Connector for internal horn (option)
18	Connector for IR cells (option, IR validation startup / Operator presence detection)
19	Connector for relay outputs R7 to R12
20	Function relay
21	Connector for safety relay outputs
22	Cable gland M25 (signal input/output)
23	Cable gland M32 for passage of « control » and power supply cables
24	Removable base
25	Main board
26	Red indicator light: status of function relays
27	Connector for relay outputs RM , R1 to R6
28	Power supply connector for Elio Receiver
29	Safety relays RS1 and RS2
30	Fuse FU1 (250V@T500mA)
31	Receiver power supply circuit

Elio

6.1.1.1 Wire terminal strips for Elio Receiver

Note: The match-up between the Transmitter control component commands and the Receiver relays is given on the configuration sheet supplied with the radio control system.

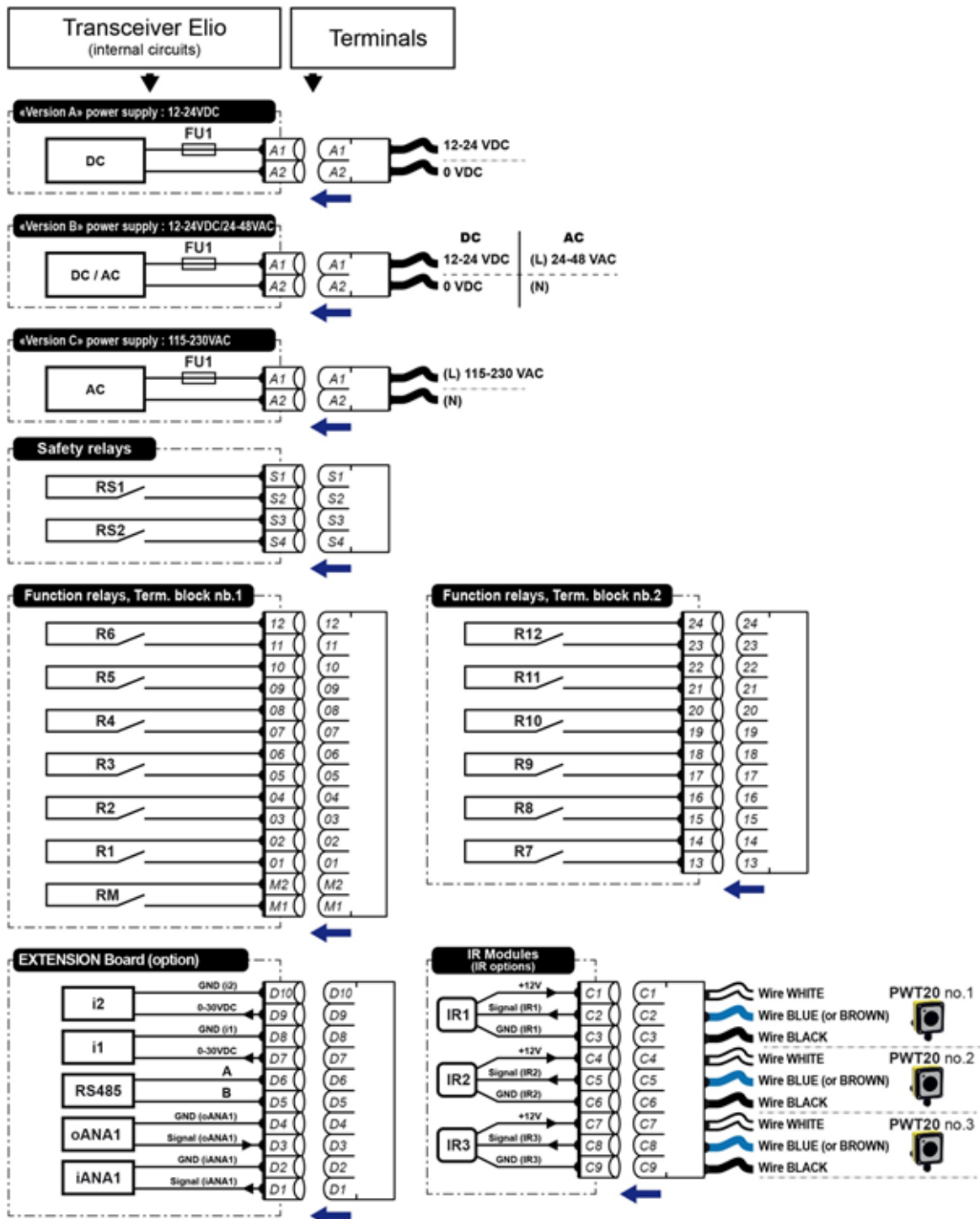

6.1.2 Alto Receiver

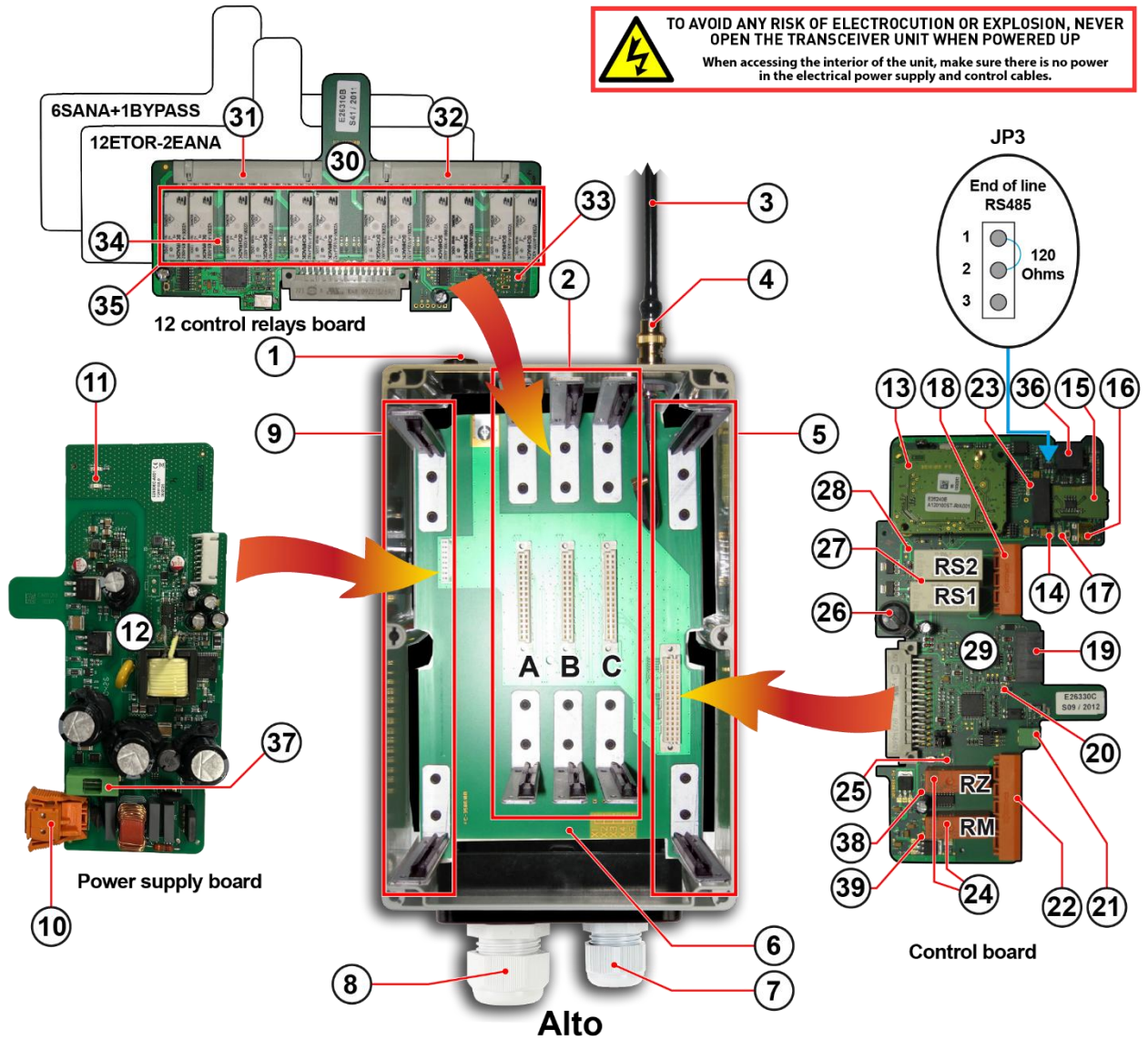

1	Breathable membrane (internal anti-condensation)
2	Positions for Input/Output board (Slot A, B, C)
3	Antenna (BNC connection)
4	Antenna BNC / antenna extension connector
5	Position for management board
6	Motherboard
7	Cable gland M25 (signal input/output)
8	Cable gland M32 for passage of « control » and power supply cables
9	Position for power supply board
10	Power supply connector for Alto Receiver
11	Yellow indicator lights 12V and 5V : board power supply OK
12	Power supply board
13	2-way radio module
14	Green indicator light LD2 : Radio reception + Diagnostics
15	SIM card (system configuration backup)
16	USB connector (configuration and diagnostics)
17	Red indicator light LD3 : Diagnostics
18	Connector for safety relay outputs
19	Connector for IR cells (option: IR validation startup / Operator presence detection)
20	Red indicator light for active On/Off input

21	Terminal strip for relays ETOR
22	Terminal strip for relays RM and RZ
23	Yellow indicator light: Control board power supply OK
24	Relays RM and RZ
25	Red indicator light LD1 : Diagnostics
26	Backup battery (daily time stamping of events)
27	Safety relays RS1 and RS2
28	Red indicator light: status of safety relays RS1 and RS2
29	Management board
30	Additional board, « 12 control relays »
31	Connector for relay outputs R7 to R12
32	Connector for relay outputs R1 to R6
33	Red and green indicator lights: Relay board status (red=fault)
34	Red indicator light: status of function relays
35	Function relays
36	Terminal strip (Analogue input 1, RS485, +5VDC output, etc.)
37	Fuse FU1 (250V@T1.6A)
38	Red indicator light: status of RZ relay
39	Red indicator light: status of RM relay

6.1.2.1 Wiring terminal strips of Alto Receiver

Note: The match-up between the Transmitter control component commands and the Receiver relays is given on the configuration sheet supplied with the radio control system.

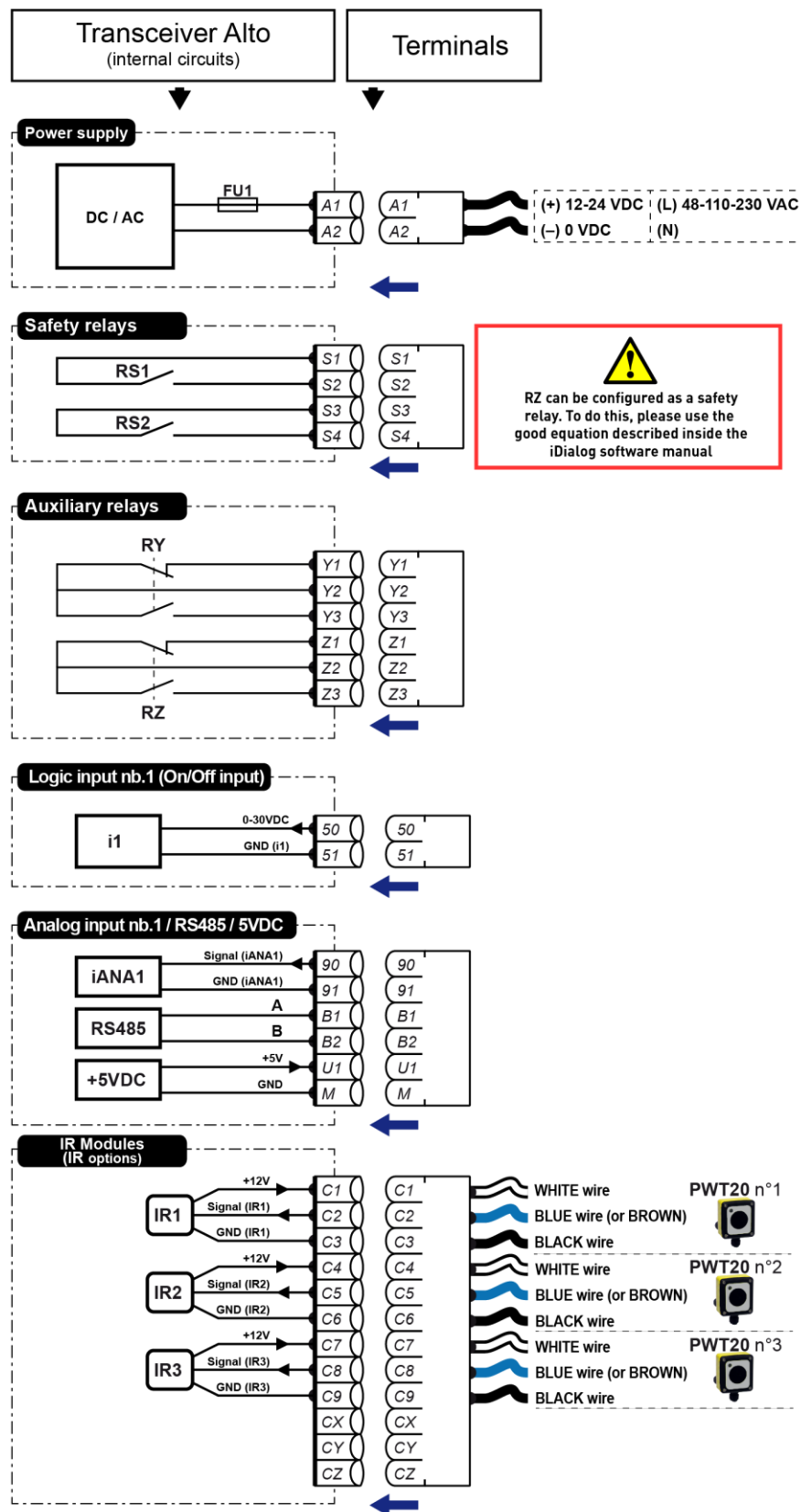

RS485 line termination (jumper JP3):

Jumper JP3 / 1-2	RS485 end of line at 120 Ohms - Modbus Network Termination
Jumper JP3 / 2-3	RS485 end of line at 1.5 kOhm - Termination Wired Link

6.1.2.2 Board with 12 control relay outputs

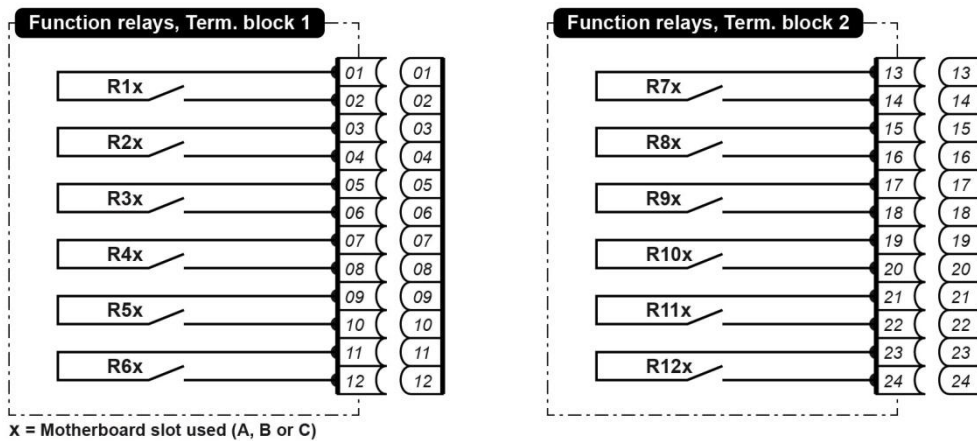

6.1.2.3 Board with 12 On/Off inputs + 2 analogue inputs

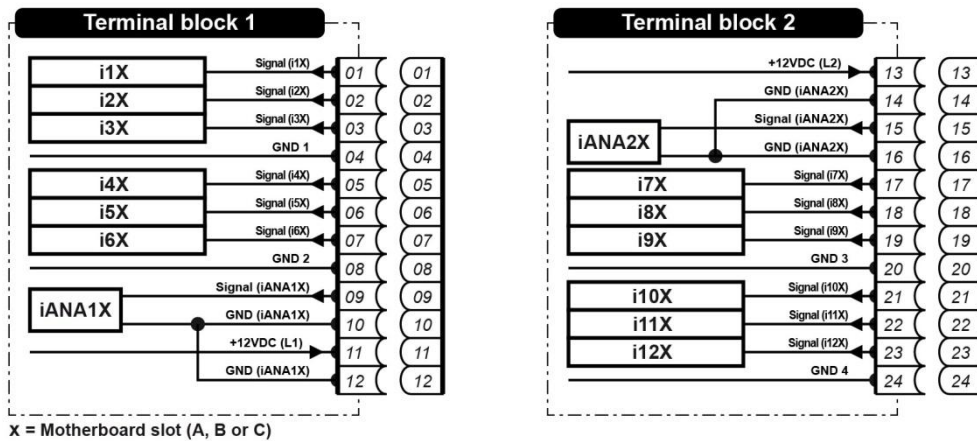

6.1.2.4 Board with 6 analogue outputs + 1 BYPASS output

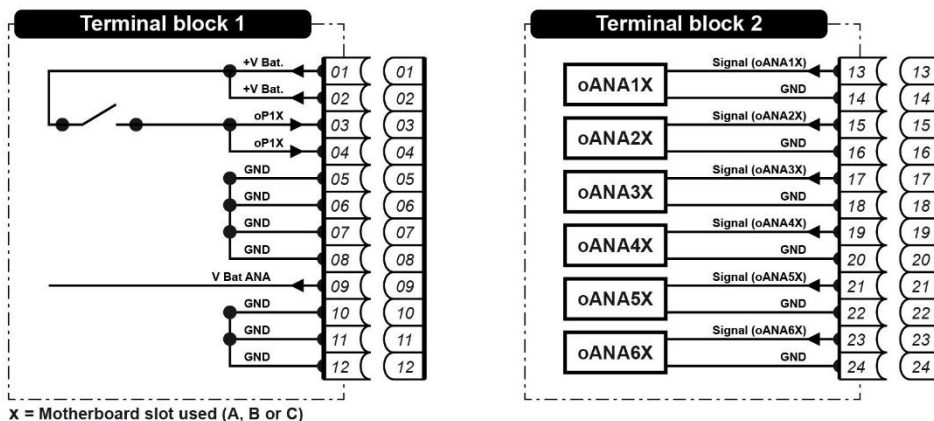

6.1.3 Timo Receiver

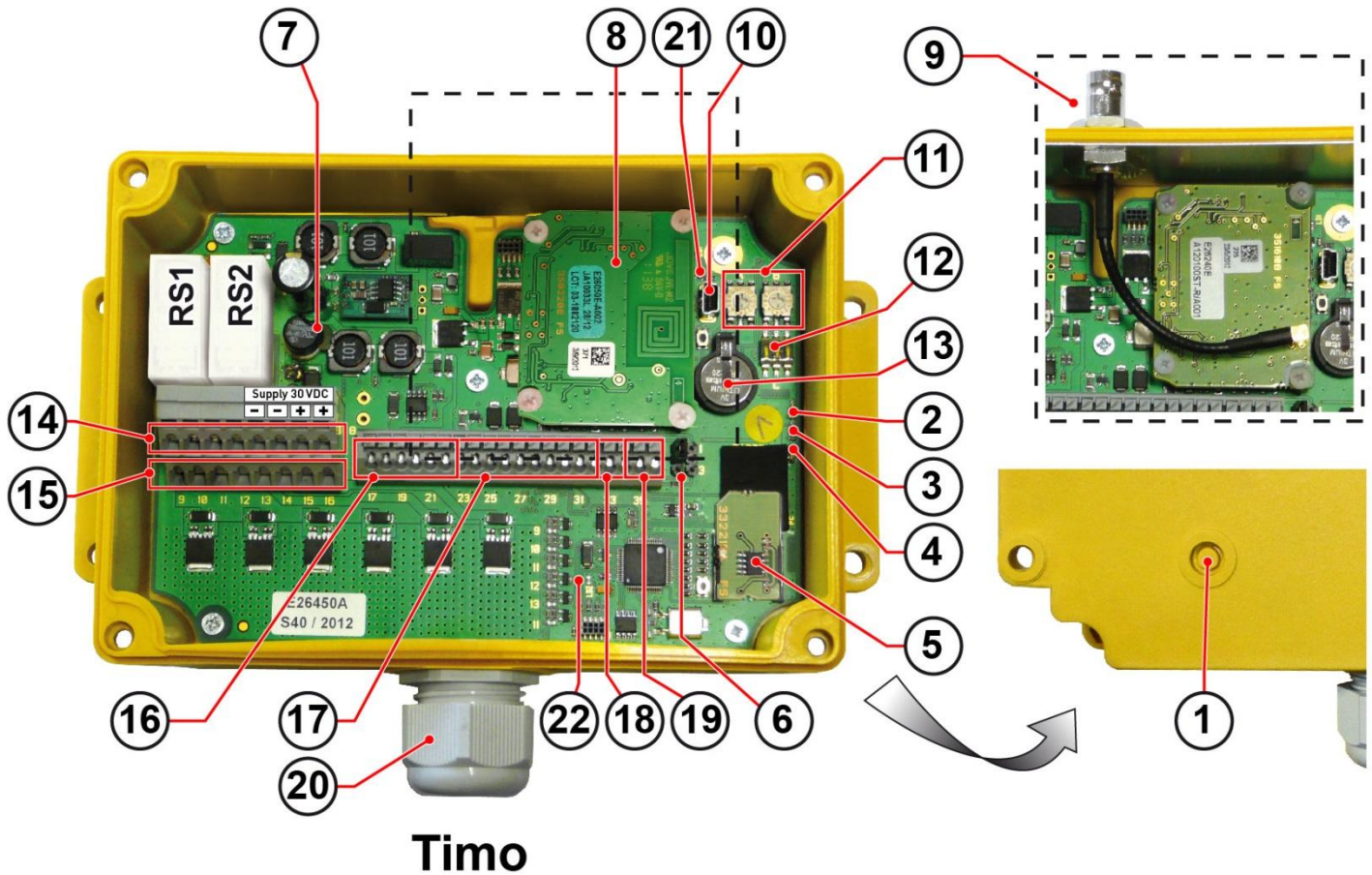

1	Breathable membrane (internal anti-condensation)
2	Yellow indicator light : Receiver power supply OK
3	Red indicator light : status of safety relays RS1 and RS2
4	Green indicator light LD2 : Radio reception + Diagnostics
5	SIM card (system configuration backup)
6	End line configuration jumpers for RS485 and CANopen links
7	Fuse FU1 (250V@T500mA)
8	2-way radio module with PCB antenna
9	Receiver Timo with option "external antenna on BNC connector"
10	USB connector (configuration and diagnostics)
11	Rotary DIP switches for bus CANopen configuration: addressing
12	DIP switch bus CANopen configuration: data rate
13	Backup battery (daily time stamping of events)
14	Terminal block: constacts of safety relays RS1 and RS2 and Receiver Power supply
15	Terminal block: On/Off or PWM outputs
16	Terminal block: Infrared cells for IR options
17	Terminal block: ANA outputs and On/Off inputs
18	Terminal block: CANopen link
19	Terminal block: RS485 link
20	M25 cable gland (according to Timo Receiver version, other connectors as: M12, C16 or industrial can be instead of or in addition of the cable gland)
21	Red indicator light LD3 : Diagnostics
22	Red indicator light LD1 : Diagnostics

6.1.3.1 Wiring terminal blocks of Timo Receiver

Note: The match-up between the Transmitter control component commands and the Receiver inputs/outputs is given on the configuration sheet supplied with the radio control system.

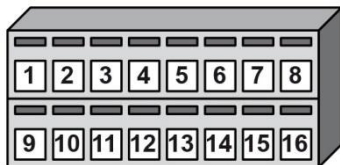

1	
2	RS1 Safety relay contact
3	
4	RS2 Safety relay contact
5	GND
6	GND (for bridging)
7	V+ Receiver Timo power supply
8	V+ Receiver Timo power supply (for bridging)
9	On/Off or PWM output nb.1 (O1)
10	On/Off or PWM output nb.2 (O2)
11	On/Off or PWM output nb.3 (O3)
12	On/Off or PWM output nb.4 (O4)
13	On/Off or PWM output nb.5 (O5)
14	On/Off or PWM output nb.6 (O6)
15	V+ On/Off or PWM outputs
16	V+ Receiver Timo power supply (for bridging)

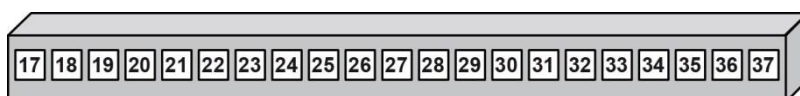

17	IR Module nb.1: GND (black wire)
18	IR Module nb.1: Signal (blue or brown wire)
19	IR Module nb.1: +12V (white wire)
20	IR Module nb.2: GND (black wire)
21	IR Module nb.2: Signal (blue or brown wire)
22	IR Module nb.2: +12V (white wire)
23	Analog input (IANA1)
24	GND
25	Analog output nb.1 (OANA1)
26	GND
27	Analog output nb.2 (OANA2)
28	GND
29	On/Off input nb.1 (i1)
30	GND
31	On/Off input nb.2 (i2)
32	GND
33	CAN Link Low
34	CAN Link High
35	RS485 Link A
36	RS485 Link B
37	+5V wired link (reserved)

(*) When using a single Infrared module, connect the "signal" terminals 18 and 21

(**) Unusable if TIMO is configured with cable link

6.1.3.2 End line configuration panel for CANopen and RS485 links

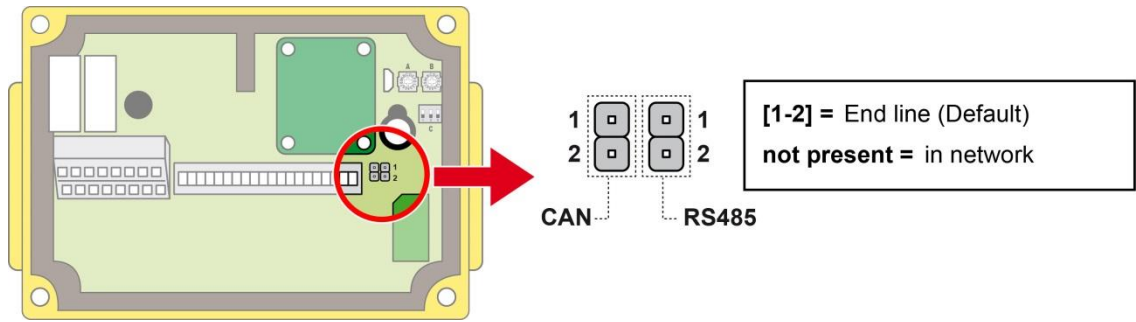

6.1.3.3 CANopen link configuration: Addressing

2 rotary switches allow to assign a slave address for the Receiver Timo.

The programmable address range is **1 to 127**.

The address must be set in hexadecimal by the two rotary switches (with **rotary switch A** = MSB).

By default, these rotary switches are on "0" position.

IMPORTANT:

Rotary switches setting must be performed when the receiver is powered off, all settings will be considered when Timo Receiver is powered on.

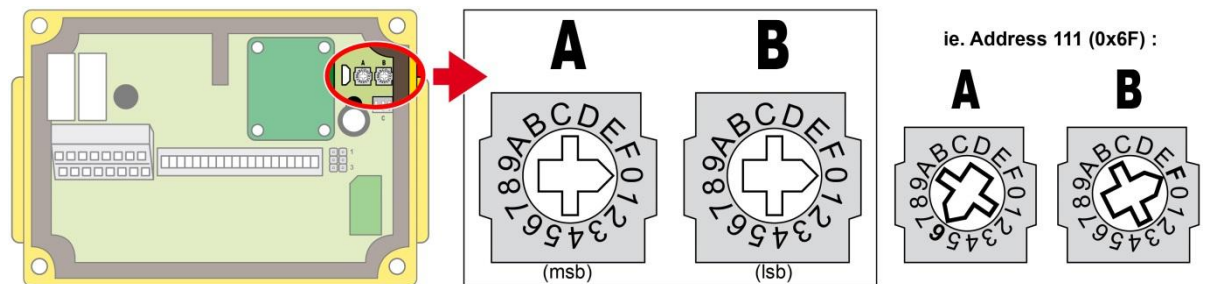

When the rotary switches are on "0" position when the Receiver is powered up, the receiver seeks application parameters related to the CANopen bus:

- If these parameters exist, they are considered (as determined by the configuration sheet or changed using software iDialog).
- If no configuration is saved, the default address is 10 (0xA).

If an address is set greater than 127 (ie 128 (0x80)), the Receiver Timo indicates a programming error by a flash of **LD1** red indicator light at power on. Then, the receiver seeks application parameters related to the CANopen bus:

- If these parameters exist, they are considered (as determined by the configuration sheet or changed using software iDialog).
- If no configuration is saved, the default address is 10 (0xA).

6.1.3.4 CANopen link configuration: data rate

A DIP switch with 3 micro switches (2 positions) allow to configure the communication rate of the Receiver Timo.

IMPORTANT:

Setting the DIP switch must be performed when Receiver is powered off, all cursor positions will be considered when the receiver Timo will be powered up.

Table of values according to the positions of the cursors:

Data rate	Cursor "1"	Cursor "2"	Cursor "3"
Non assigned	OFF	OFF	OFF
20 kbits/s	OFF	OFF	ON
50 kbits/s	OFF	ON	OFF
100 kbits/s	OFF	ON	ON
250 kbits/s	ON	OFF	OFF
500 kbits/s	ON	OFF	ON
800 kbits/s	ON	ON	OFF
1000 kbits/s	ON	ON	ON

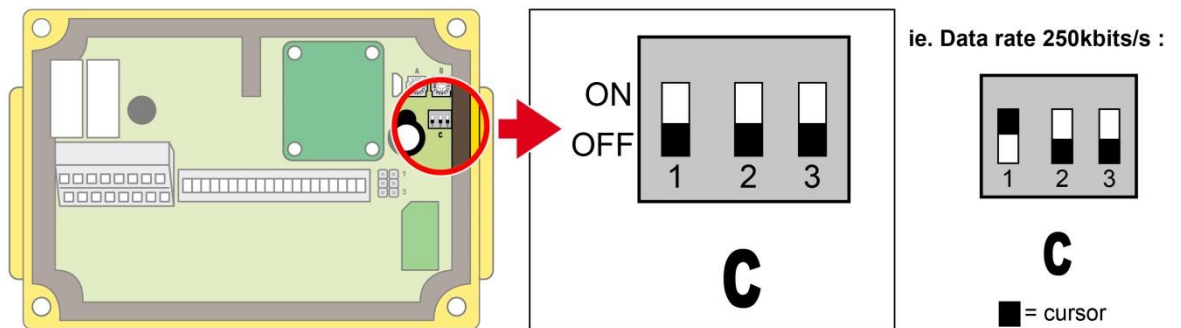

When cursors are on "0" positions when the Receiver is powered up, the receiver seeks application parameters related to the CANopen bus:

- If these parameters exist, they are considered (as determined by the configuration sheet or changed using software iDialog).
- If no configuration is saved, the default data rate is 125 Kbits/s.

6.1.4 Receiver Nemo

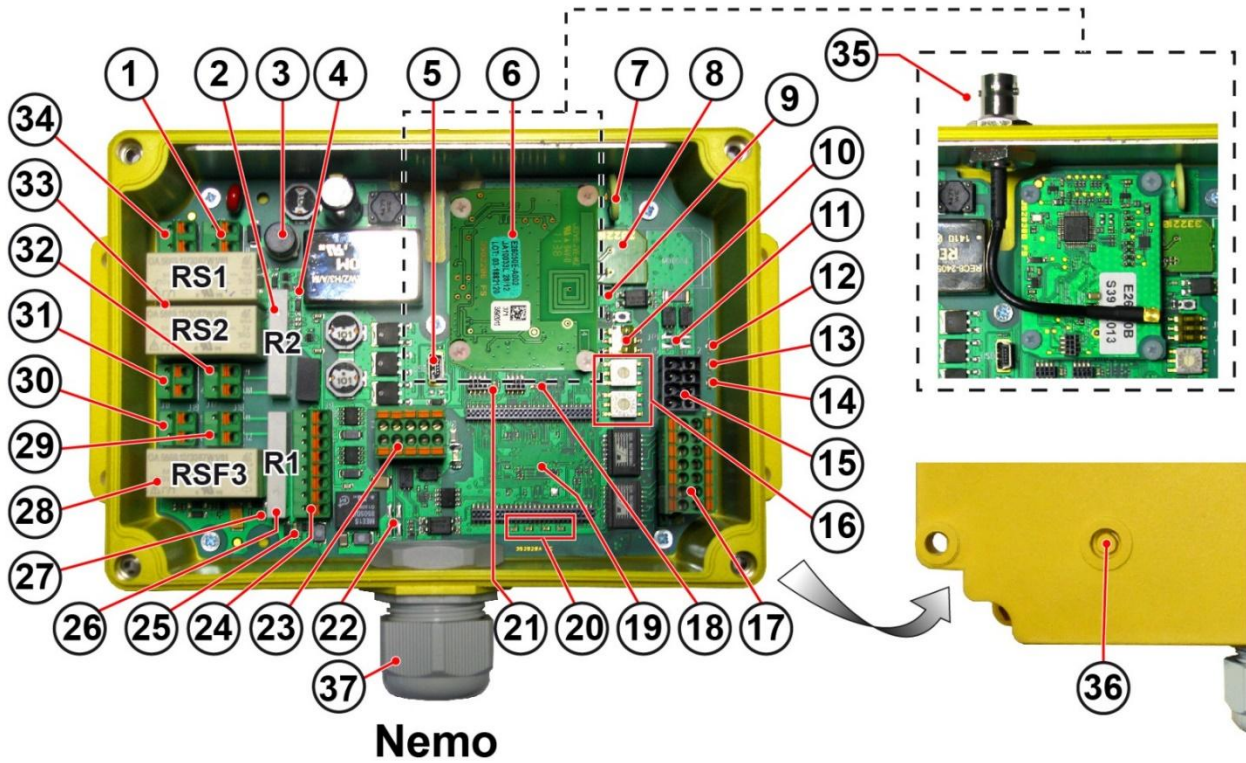

Nemo

1	Terminal block: Receiver Power Supply (see next page)
2	Function relay R2
3	Fuse FU1 (250V@T2A)
4	Red indicator light LD7 : Function relay R2 activated
5	USB connector (configuration and diagnostics)
6	2-way radio module with PCB antenna
7	Backup battery (daily time stamping of events)
8	SIM card (system configuration backup)
9	Red indicator light LD13 : On/Off input activated
10	DIP switch bus CANopen configuration: data rate
11	End line configuration jumpers JP1 and JP2 : RS485 and CANopen
12	Yellow indicator light V+ (LD8): Receiver power supply OK
13	Red indicator light LD5 : status of safety relays RS1 and RS2
14	Green indicator light LD2 : Radio reception + Diagnostics
15	Terminal block: CANopen and RS485 Links (see next page)
16	Encoding Wheels for bus CANopen and Profibus ¹ parameter setting: addressing
17	Terminal block: Ethernet bus (option) (see next page)
18	Red indicator light LD1 : Diagnostic
19	Location for the communication bus card (option)
20	Indicator lights LD9 (green), LD10 (red), LD11 (green) and LD12 (red): Status for network and communication bus card

21	Red indicator light LD3 : Diagnostic
22	End line configuration jumpers JP3 and JP4 : PROFIBUS-CCLINK (option) and DEVICENET (option)
23	Terminal block: PROFIBUS-CCLINK (option) and DEVICENET (option) (see next page)
24	Terminal block: IR Modules (IR option) and cable link (option) (see next page)
25	Red indicator light LD4 : Function relay R1 activated
26	Function relay R1
27	Red indicator light LD6 : safety relay for common control RSF3 activated
28	Safety relay for common control RSF3
29	Terminal block: output contact of function relay R1
30	Terminal block: output contact of safety relay for common control RSF3
31	Terminal block: output contact of safety relay RS2
32	Terminal block: output contact of function relay R2
33	Safety relays RS1 and RS2
34	Terminal block: output contact of safety relay RS1
35	Receiver Nemo with option "external antenna on BNC connector"
36	Breathable membrane (internal anti-condensation)
37	M25 Cable gland (an additional M16 cable gland will be present for IR option, an M12 connector will be present for communication bus option).

¹ Only per encoder wheel for Profibus

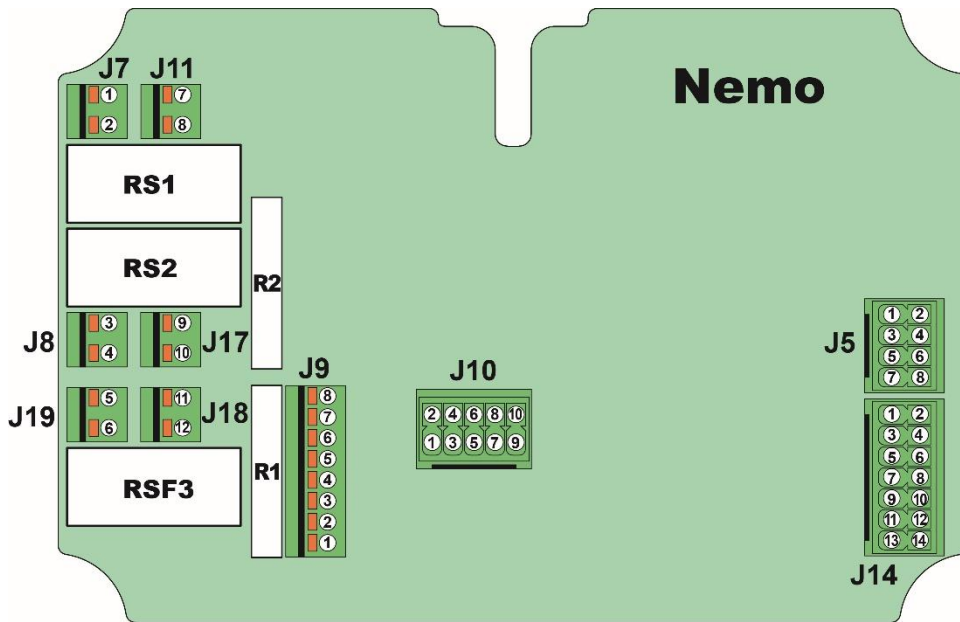

6.1.4.1 Wiring terminal blocks of Nemo Receiver

Note: The match-up between the Transmitter control component commands and the Receiver inputs/outputs is given on the configuration sheet supplied with the radio control system.

Receiver Nemo POWER SUPPLY

J11



Contacts of safety relays RS1 and RS2, and common safety relay RSF3

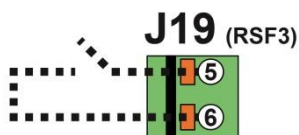
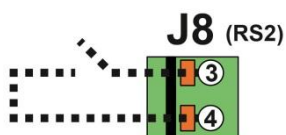
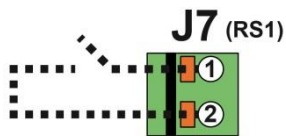



RSF3 can be configured as a safety relay.
To do it, please use the right equation described inside IDialog user manual.

Contacts of function relays R1 and R2

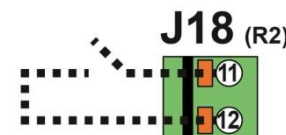
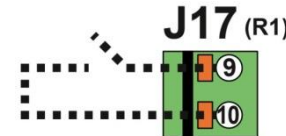

■ Other terminal blocks

T.block terminal	Function / item	Characteristics / description
J9 - 3	IR option – IR module no 1	V+ IR module no 1 (white wire)
J9 - 4	IR option – IR module no 1	Signal (brown or blue wire)
J9 - 5	IR option – IR module no 1	GND (black wire)
J9 - 6	IR option – IR module no 2	V+ IR module no 2 (white wire)
J9 - 7	IR option – IR module no 2	Signal (brown or blue wire)
J9 - 8	IR option – IR module no 2	GND (black wire)
J10 - 1	DEVICENET option	V+ bus
J10 - 2	DEVICENET option	V- bus
J10 - 3	DEVICENET option	CAN-L
J10 - 4	DEVICENET option	CAN-H
J10 - 5	PROFIBUS – CCLINK option	+5VDC (insulated) **
J10 - 6	PROFIBUS – CCLINK option	GND (insulated) **
J10 - 7	PROFIBUS – CCLINK option	A
J10 - 8	PROFIBUS – CCLINK option	B
J10 - 9	PROFIBUS – CCLINK option	Shielding
J10 - 10	PROFIBUS – CCLINK option	RTS
J5 - 1	On/Off input	V+ (+30VDC max) **
J5 - 2	On/Off input	GND (insulated) **
J5 - 3	MODbus RS485	A serial link **
J5 - 5	MODbus RS485	B serial link **
J5 - 7	MODbus RS485	GND **
J5 - 4	CANopen	CANopen-H
J5 - 6	CANopen	CANopen-L
J5 - 7	CANopen	GND
J5 - 8	CANopen	Shielding
J14 - 1	Communication bus option*	TDA+ (Ethernet A) (Ethercat IN PORT)
J14 - 2	Communication bus option*	TDA- (Ethernet A) (Ethercat IN PORT)
J14 - 3	Communication bus option*	RDA+ (Ethernet A) (Ethercat IN PORT)
J14 - 4	Communication bus option*	not used
J14 - 5	Communication bus option*	RDA- (Ethernet A) (Ethercat IN PORT)
J14 - 6	Communication bus option*	not used
J14 - 7	Communication bus option*	Shielding (Ethernet A) (Ethercat IN PORT)
J14 - 8	Communication bus option*	Shielding (Ethernet B) (Ethercat OUT PORT)
J14 - 9	Communication bus option*	TDB+ (Ethernet B) (Ethercat OUT PORT)
J14 - 10	Communication bus option*	TDB- (Ethernet B) (Ethercat OUT PORT)
J14 - 11	Communication bus option*	RDB+ (Ethernet B) (Ethercat OUT PORT)
J14 - 12	Communication bus option*	not used
J14 - 13	Communication bus option*	RDB- (Ethernet B) (Ethercat OUT PORT)
J14 - 14	Communication bus option*	not used

** Unusable if NEMO is configured with cable link

* = ETHERNET (A/B) / POWERLINK / PROFINET / Modbus TCP/IP/ Ethernet/IP

Note 1: The match-up between the Transmitter control component commands and the Receiver inputs/outputs is given on the configuration sheet supplied with the radio control system.

Note 2: See the corresponding Commissioning Manual supplied with the product, for:



BUS EtherCAT, user manuel: 353210



BUS PROFIBUS, user manuel: 353220



BUS PROFINET, user manuel: 353250



BUS MODBUS TCP/IP, user manuel: 353330



BUS POWERLINK, user manuel: 333250



BUS Ethernet IP, user manuel: 353340

6.1.4.2 End line configuration panel for CANopen and RS485 links

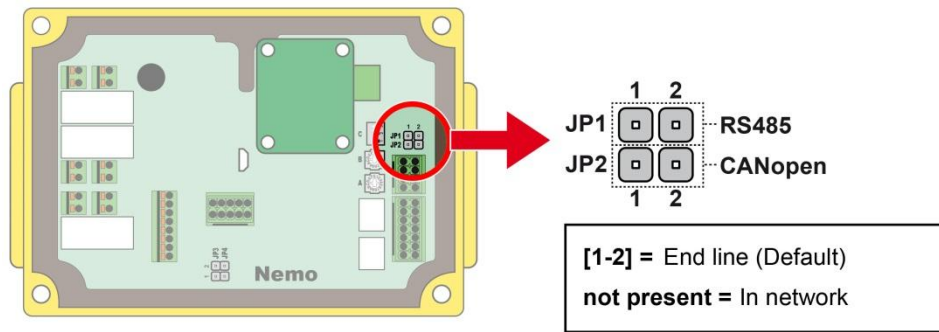

6.1.4.3 Addressing configuration for CANopen, MODBUS, PROFIBUS² and POWERLINK

2 rotary switches allow to assign a slave or node address for the Receiver Nemo.

The address must be set in hexadecimal by the two rotary switches (with **rotary switch A** = MSB). By default, these rotary switches are on “0” position.

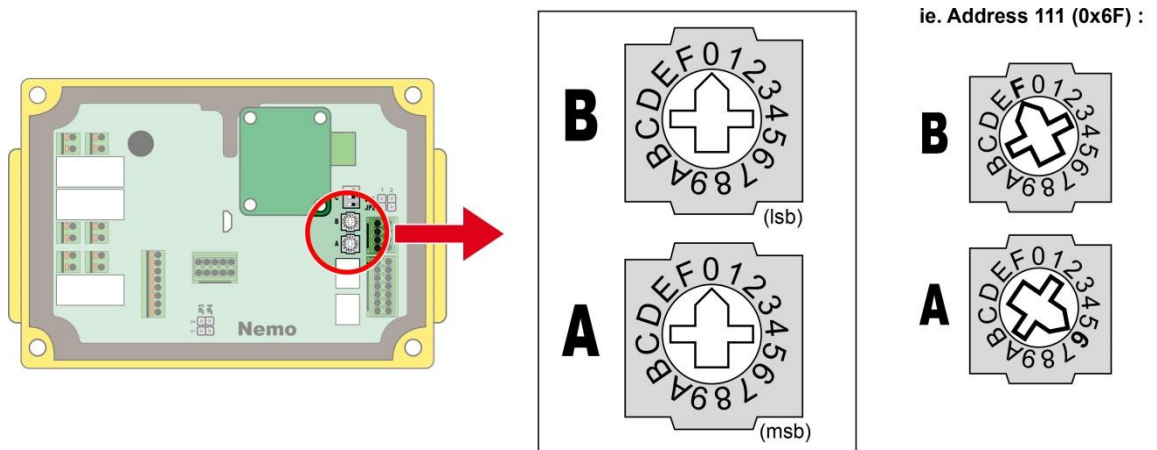

IMPORTANT:

If the rotary switches are on “0” position when the Receiver is powered up, the receiver seeks application parameters related to iDialog network settings:

- If these parameters exist, they are considered (as determined by the iDialog parameter file).
- If no iDialog configuration is set, the default address is **10 (0xA)**.

The programmable address range for **CANopen** is **1 to 127**.

The programmable address range for **MODBUS** is **1 to 247**.

The programmable address range for the **PROFIBUS** is **1 to 125**. If **126** is set, the master can modify the PROFIBUS NEMO address

The programmable address range for **POWERLINK** is **1 to 239**.

If rotary switches are set greater than programmable address range, the Receiver Nemo indicates a programming error by a flash of **LD1** red indicator light at power on. Then, the receiver seeks application parameters related to the CANopen bus or Profibus:

- If these parameters exist, they are considered (as determined by the iDialog parameter file).
- If no iDialog configuration is set, the default address is **10 (0xA)**.

IMPORTANT:

Rotary switches setting must be changed when the receiver is powered off, all settings will be considered when Nemo Receiver will be powered up.

² Only by coding wheel for Profibus

6.1.4.4 CANopen link configuration: data rate

A DIP switch with 3 micro switches (2 positions) allow to configure the communication rate of the Receiver Nemo.

IMPORTANT:

Setting the DIP switch must be performed when Receiver is powered off, all cursor positions will be considered when the receiver Nemo will be powered up.

Table of values according to the positions of the cursors:

Data rate	Cursor "1"	Cursor "2"	Cursor "3"
Non assigned	OFF	OFF	OFF
20 kbits/s	OFF	OFF	ON
50 kbits/s	OFF	ON	OFF
100 kbits/s	OFF	ON	ON
250 kbits/s	ON	OFF	OFF
500 kbits/s	ON	OFF	ON
800 kbits/s	ON	ON	OFF
1000 kbits/s	ON	ON	ON

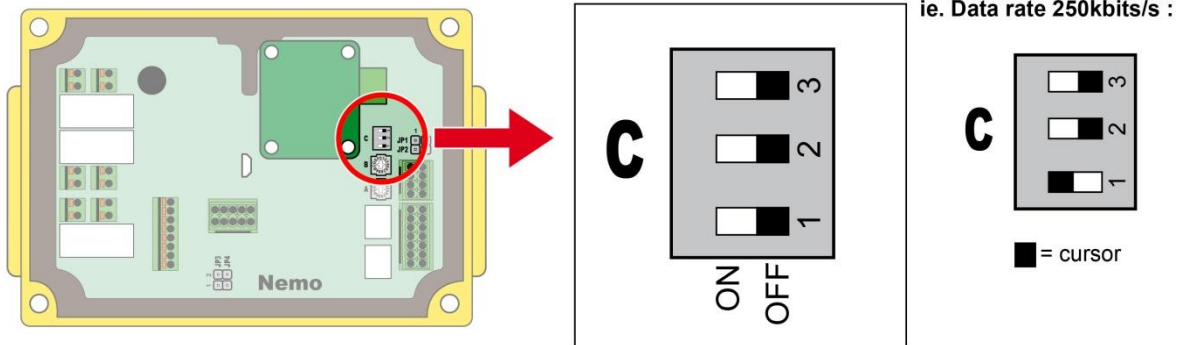

When cursors are on "0" positions when the Receiver is powered up, the receiver seeks application parameters related to the CANopen bus:

- If these parameters exist, they are considered (as determined by the configuration sheet or changed using software iDialog).
- If no configuration is saved, the default data rate is 125 Kbits/s.

6.1.4.5 End line configuration panel for options: DEVICENET or PROFIBUS-CCLINK

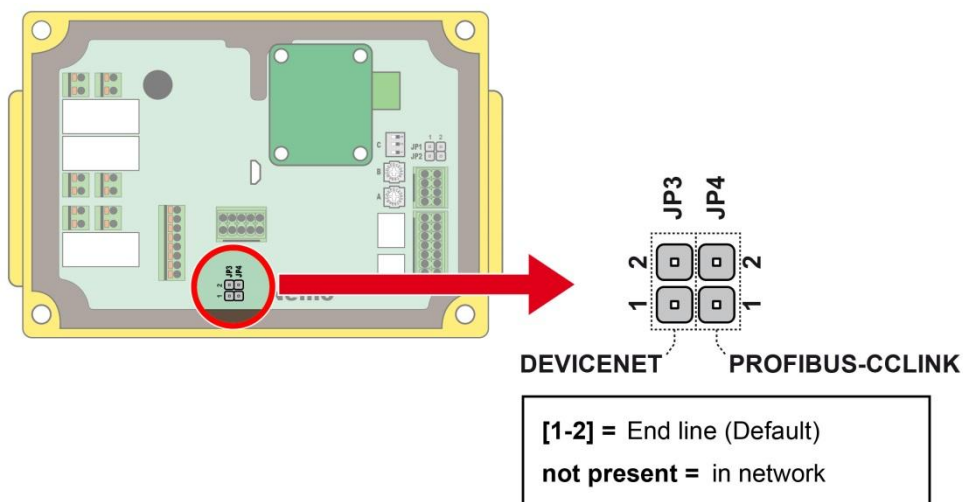

6.1.4.6 Meanings of LEDs

6.1.4.6.1 Modbus IP

Network status

LED State	Indication
Off	No IP address or in state EXCEPTION
Green	At least one Modbus message received
Flashing Green	Waiting for first Modbus message
Red	IP address conflict detected, FATAL ERROR
Red, flashing	Connection timeout. No Modbus message has been received within the configured "process active timeout" time

A test sequence is performed on this LED during startup.

Module status

LED State	Indication
Off	No power
Green	Normal operation
Red	Major fault (including Anybus exception), FATAL
Red, flashing	Minor fault
Alternating red/green	Firmware update from file system in progress

A test sequence is performed on this LED during startup.

6.1.4.6.2 DeviceNet

Network status

LED State	Indication
Off	Not online / No network power
Green	On-line, one or more connections are established
Flashing Green (1Hz)	On-line, no connections established
Red	Critical link failure, fatal event
Flashing Red (1Hz)	One or more connections timed-out
Alternating red/green	Executing self test

Module status

LED State	Indication
Off	Not operating
Green	Operating in normal condition
Flashing Green (1Hz)	Missing, incorrect or incomplete configuration, device needs commissioning.
Red	Unrecoverable Fault(s)
Flashing Red (1Hz)	Recoverable Fault(s)
Alternating red/green	Executing self test

6.1.4.6.3 EtherCAT

Network status

This LED reflects the status of the EtherCAT device.

LED State	Indication	Comments
Off	INIT	EtherCAT device in 'INIT'-state (or no power)
Green	OPERATIONAL	EtherCAT device in 'OPERATIONAL'-state
Green, blinking	PRE-OPERATIONAL	EtherCAT device in 'PRE-OPERATIONAL'-state
Green, 1 flash	SAFE-OPERATIONAL	EtherCAT device in 'SAFE-OPERATIONAL'-state
Flickering	BOOT	The EtherCAT device is in 'BOOT' state
Red	(Fatal Event)	If RUN and ERR turn red, this indicates a fatal event, forcing the bus interface to a physically passive state. Contact HMS technical support.

Module status

This LED indicates EtherCAT communication errors etc.

LED State	Indication	Comments
Off	No error	No error (or no power)
Red, blinking	Invalid configuration	State change received from master is not possible due to invalid register or object settings.
Red, 1 flash	Unsolicited state change	Slave device application has changed the EtherCAT state autonomously.
Red, 2 flashes	Sync Manager watchdog timeout	See Watchdog Functionality, p. 16 for more information.
Red	Application controller failure	Anybus module in EXCEPTION. If RUN and ERR turn red, this indicates a fatal event, forcing the bus interface to a physically passive state. Contact HMS technical support.
Flickering	Booting error detected	E.g. due to firmware download failure.

6.1.4.6.4 Powerlink

Network status

LED State	Indication
Off	No error
Red	If the STATUS LED is not red, a non-fatal error has been detected. If the STATUS LED is red, a fatal event was encountered.

Module status

LED State	Indication
Off	Module is off, initializing, or not active.
Green, fast flashing (on 50 ms, off 50 ms) NMT_CS_BASIC_ETHERNET	NMT_CS_BASIC_ETHERNET Basic Ethernet state: no POWERLINK traffic has been detected.
Green, single flash	NMT_CS_PRE_OPERATIONAL_1. Only asynchronous data.
Green, double flash	NMT_CS_PRE_OPERATIONAL_2. Asynchronous and synchronous data. No PDO data. Any process data sent is declared not valid and process data received must be ignored in this state.
Green, triple flash	NMT_CS_READY_TO_OPERATE. Ready to operate. Asynchronous and synchronous data. No PDO data. Any process data sent is declared not valid and process data received must be ignored in this state.
Green	NMT_CS_OPERATIONAL. Fully operational. Asynchronous and synchronous data. PDO data is sent and received.
Green, slow flashing (on 200 ms, off 200 ms)	NMT_CS_STOPPED Module stopped (for controlled shutdown, for example). Asynchronous and synchronous data. No PDO data. Any process data sent is declared not valid and process data received must be ignored in this state.
Red	If the ERROR LED also is red, a fatal event was encountered.

6.1.4.6.5 EtherNet IP

Network status

LED State	Indication
Off	No power or no IP address
Green	Online, one or more connections established (CIP Class 1 or 3)
Green, flashing	Online, no connections established
Red	Duplicate IP address, FATAL error
Red, flashing	One or more connections timed out (CIP Class 1 or 3)

A test sequence is performed on this LED during startup.

Module status

LED State	Indication
Off	No power
Green	Controlled by a Scanner in Run state and, if CIP Sync is enabled, time is synchronized to a Grandmaster clock
Green, flashing	Not configured, Scanner in Idle state, or, if CIP Sync is enabled, time is synchronized Grandmaster clock
Red	Major fault (EXCEPTION-state, FATAL error etc.)
Red, flashing	Recoverable fault(s). Module is configured, but stored parameters differ from currently used parameters.

A test sequence is performed on this LED during startup.

6.1.4.6.6 PROFIBUS

Network status

LED State	Indication	Comments
Off	Not online / No power	-
Green	Online, data exchange	-
Flashing Green	Online, clear	-
Flashing Red (1 flash)	Parameterization error	See Parameterization Data Handling, p. 14
Flashing Red (2 flashes)	PROFIBUS Configuration error	See Configuration Data Handling, p. 15

Module status

LED State	Indication	Comments
Off	Not initialized	Anybus state = SETUP or NW_INIT
Green	Initialized	Anybus module has left the NW_INIT state
Flashing Green	Initialized, diagnostic event(s) present	Extended diagnostic bit is set
Red	Exception error	Anybus state = EXCEPTION

Network status

LED State	Indication	Comments
Off	Offline	<ul style="list-style-type: none"> No power No connection with IO Controller
Green	Online (RUN)	<ul style="list-style-type: none"> Connection with IO Controller established IO Controller in RUN state
Green, 1 flash	Online (STOP)	<ul style="list-style-type: none"> Connection with IO Controller established IO Controller in STOP state or IO data bad IRT synchronization not finished
Green, blinking	Blink	Used by engineering tools to identify the node on the network
Red	Fatal event	Major internal error (this indication is combined with a red module status LED)
Red, 1 flash	Station Name error	Station Name not set
Red, 2 flashes	IP address error	IP address not set
Red, 6 flashes	Configuration error	Expected Identification differs from Real Identification

Module status

LED State	Indication	Comments
Off	Not initialized	No power OR Module in SETUP or NW_INIT state.
Green	Normal Operation	Module has shifted from the NW_INIT state.
Green, 1 flash	Diagnostic Event(s)	Diagnostic event(s) present
Red	Exception error	Device in state EXCEPTION.
	Fatal event	Major internal error (this indication is combined with a red network status LED)
Alternating Red/Greed	Firmware update	Do NOT power off the module. Turning the module off during this phase could cause permanent damage.

6.2 SIM card

A **SIM** card is supplied with the Receiver.

The **SIM** card contains the configuration corresponding to the radio-controlled application. This memory is called the “application memory”.

The radio control system **cannot operate without the “application memory”**.

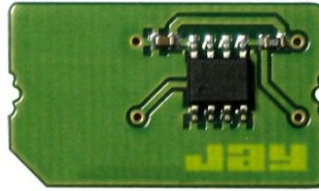

On delivery, the **SIM** card must be installed in the Receiver on a specific connector of the management board.



TO AVOID ANY RISK OF ELECTROCUTION, NEVER OPEN THE TRANSCEIVER HOUSING WHICH IS POWERED UP.
The opening of the housing must be done by ensuring that the power supply cables and control cables are out of voltage

1 Detach the SIM card from its holder

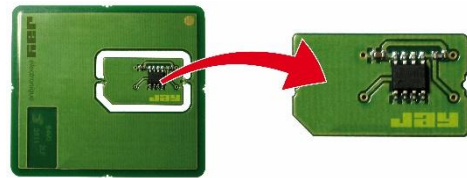

2 Locate connector Receiver board

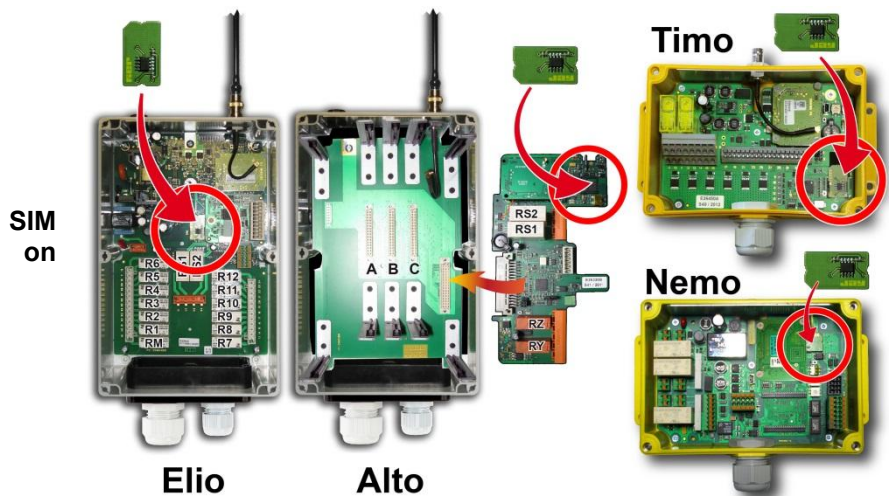

3 Insert the SIM card into the connector

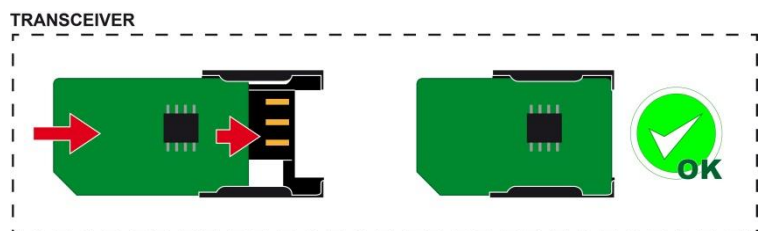

6.3 USB connection

Using the USB connection is possible only when the receiver is powered off.



TO AVOID ANY RISK OF ELECTROCUTION, NEVER OPEN THE TRANSCEIVER HOUSING WHICH IS POWERED UP.
The opening of the housing must be done by ensuring that the power supply cables and control cables are out of voltage

6.4 Receiver indicator light functions and messages

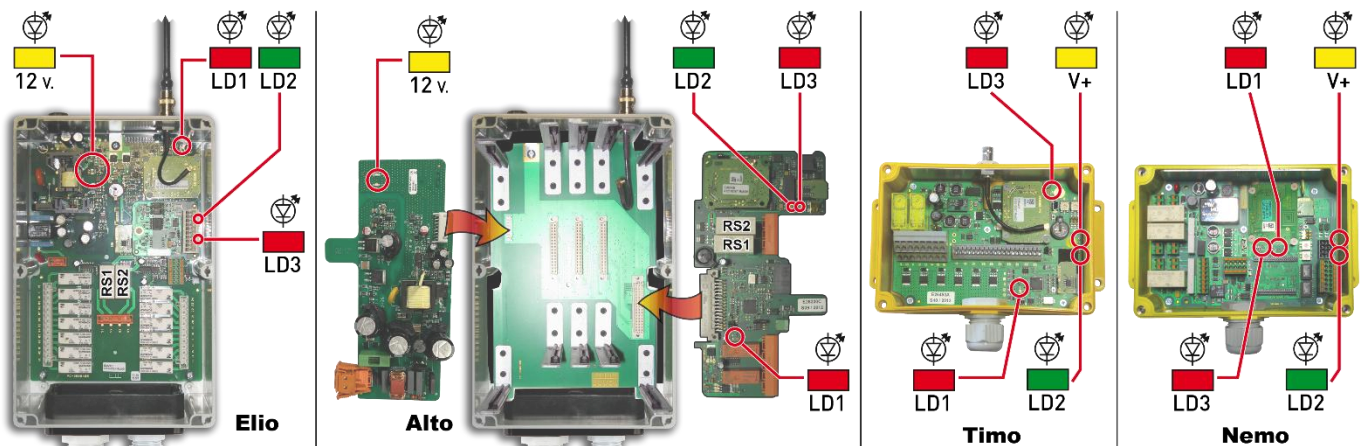

Safe Mode = The Receiver is energized, and standby for a « Start » order

Operating mode = The Receiver is started, its safety relays **RS1** and **RS2** are activated and their contacts are closed

Messages in nominal operating condition:

Mode	LD1 (red)	LD3 (red)	LD2 (green)	12V - power. V+ power. (yellow)	Description
Safe	OFF	OFF	OFF	ON	Nominal operating state
Safe	OFF	OFF	Flashing	ON	The Receiver is in "Association" mode
Safe	Flashing with pauses for a second	OFF	Flashing with pauses for a second	ON	The Receiver is in configuration mode with the Transmitter
Operating	OFF	OFF	ON and OFF for a short period (once per second)	ON	Nominal operating state

Messages in case of errors or operating problems:

Mode	LD1 (red)	LD3 (red)	LD2 (green)	Power (yellow)	Description
When powering up	OFF				Power problem, check fuse(s) or power cables
Under voltage	ON		OFF	ON	Hardware or software defect that prevents starting. Read the logbook and contact the after-sales service.
Under voltage	Flashing lights 2 flashes		OFF	ON	SIM or EEprom fault. Check and/or reload the parameterization sheet.
Under voltage	OFF	8 fast flashes	OFF	ON	Additional card defect. Check unexpected presence/absence, positioning error...
Under voltage	OFF	8 slow flash	OFF	ON	Default time internal clock. Check time (iDialog), check battery.
Under voltage	Cycle LD1 LD3 ON and LD2 OFF / LD1 LD3 OFF and LD2 ON			ON	Synchronization in progress. Wait for restart.
Under voltage	OFF		1 Flash	ON	Indicator for the reception of a radio frame.
Under voltage	OFF		3 Flashes	ON	Indicator for the reception of a radio frame with an unrecognized identity code

6.5 Use of safety relay RSF3

The output of safety relay function **RSF3** or **RZ** have a performance level Category 2/PLd - SIL 2. This output could be used to open circuit of relays **R1** and **R2** or every functional relay on the ALTO directly or by an external contactor. If you use an external contactor you need to evaluate what performance level the whole system can achieve themselves.

The function of outputs **RSF3** or **RZ**, **R1** and **R2** or functional relay on the ALTO are configurable with **iDialog** software. Please check the IDialog user manual to know how to configure RSF3 or RZ as a safety relay.

RSF3 has to be powered by **RS1** or **RS2**. In case of failure, **RS1** and **RS2** will be de-energized.

Wiring example of the outputs:

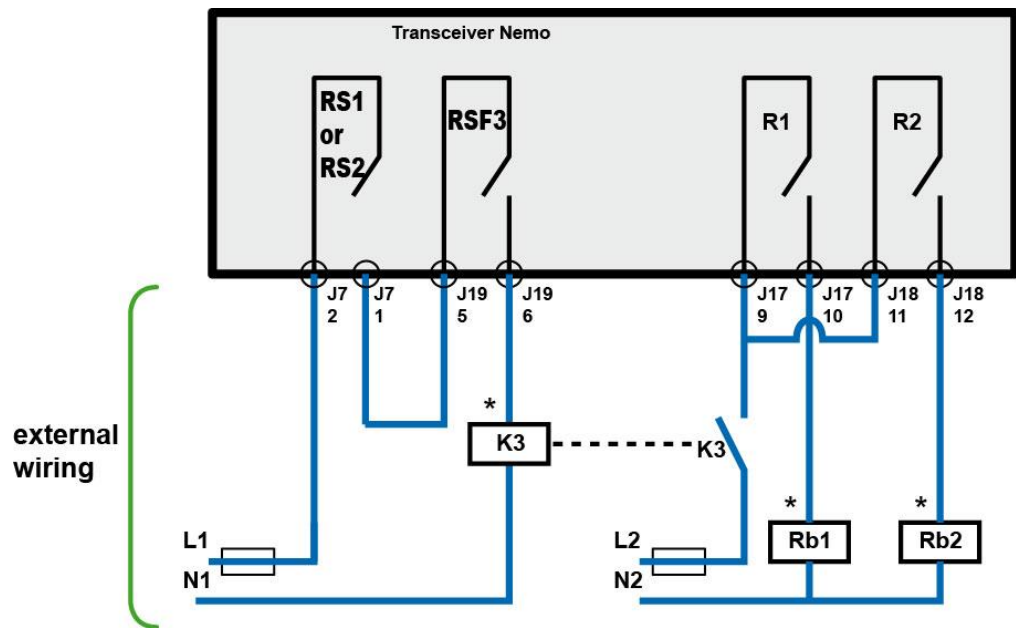

K3 is a guided contact contactor, to be integrated in the safety circuit of the system controlled.

* = The use of overvoltage limiting circuits will increase the service life of the relay contacts (ex: RC circuits with AC, diodes + Zener with DC, etc.).



The function relays R1, R2 of NEMO or function relays of ALTO are not part of the safety function.
Only RSF3 and RZ are monitored.

RSF3 and RZ must be placed to cut the power supply which go throw the functional relay.

To know how to configure RZ and RSF3, please check the IDialog user manual.

7 Options and special functions

7.1 “Start-up by infrared validation” function

The start-up area of an equipment and the equipment’s identification can be secured by an infrared validation on start-up.

To start up the equipment, the user must:

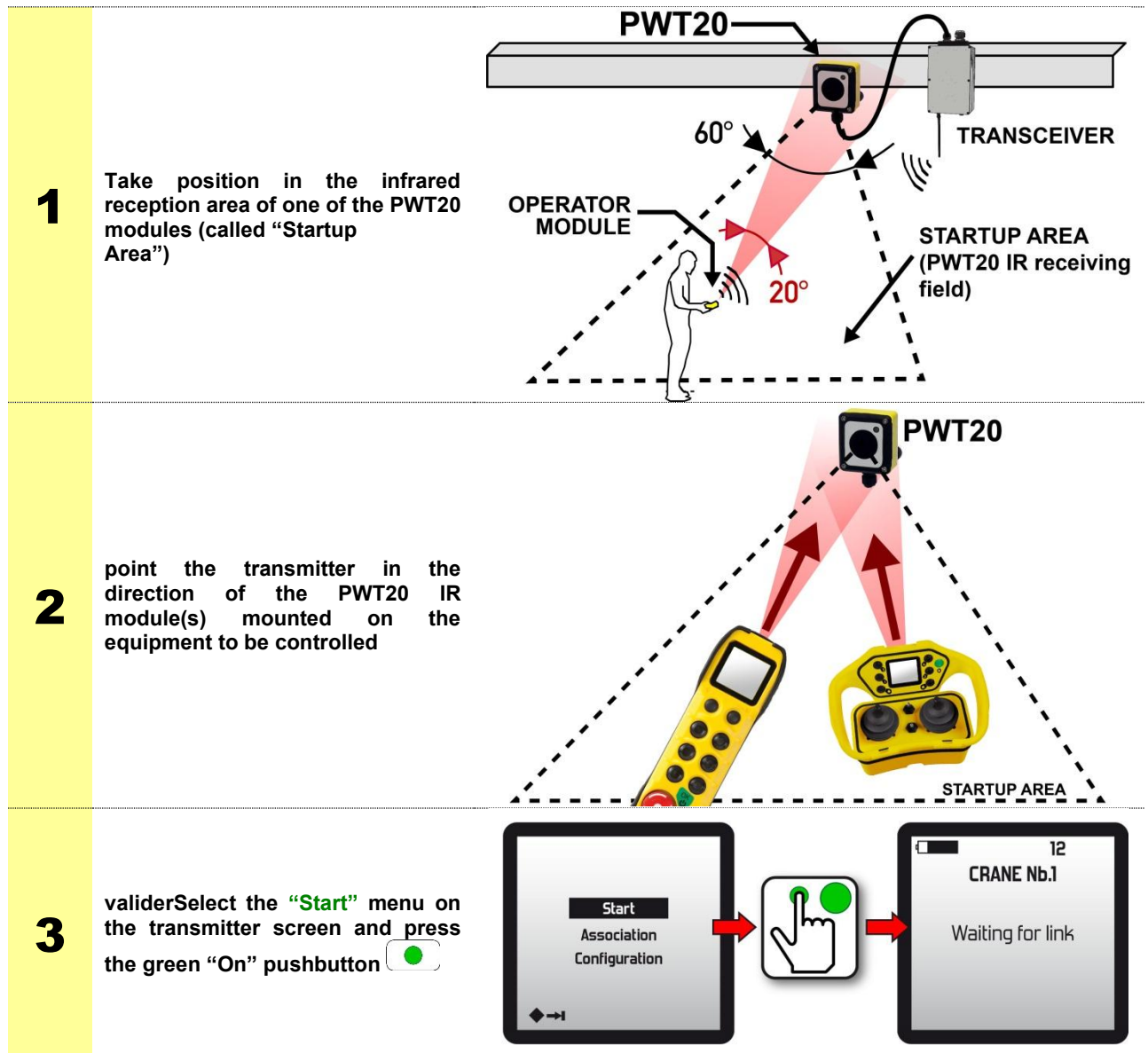

Once the validation has been performed, the «Transmitter and the Equipment to be controlled» are matched up with no possibility for error. The operator can then move freely with no limitation.

- Up to 3 IR **PWT20** modules can be connected to Receiver Alto and Elio.
- Up to 2 IR **PWT20** modules can be connected to Receiver Timo and Nemo.

- The infrared startup function has a range of action described in the tables below:

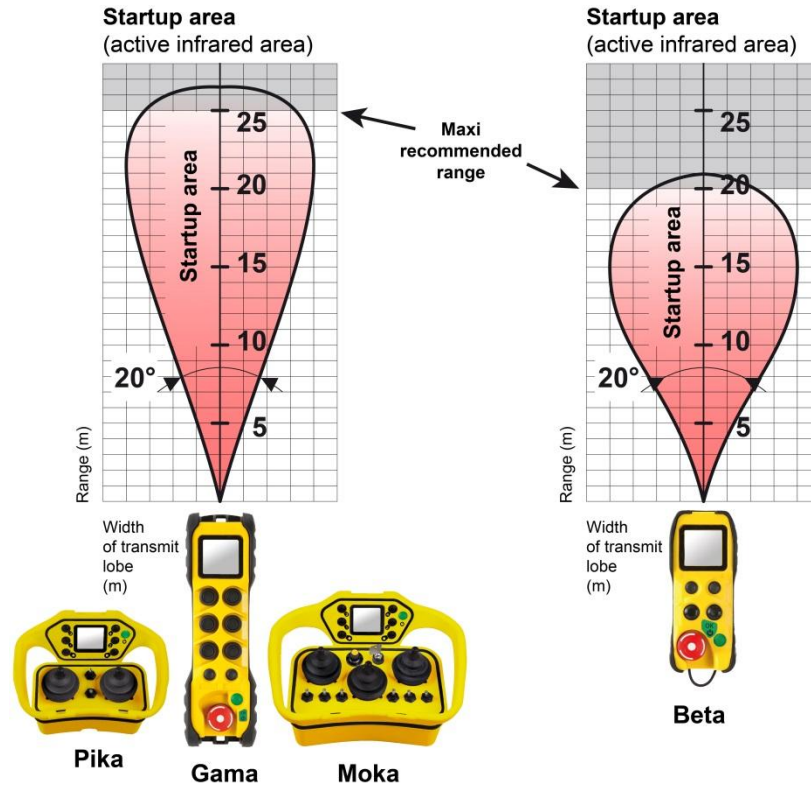

7.1.1 Examples of PWT20 IR modules positioning

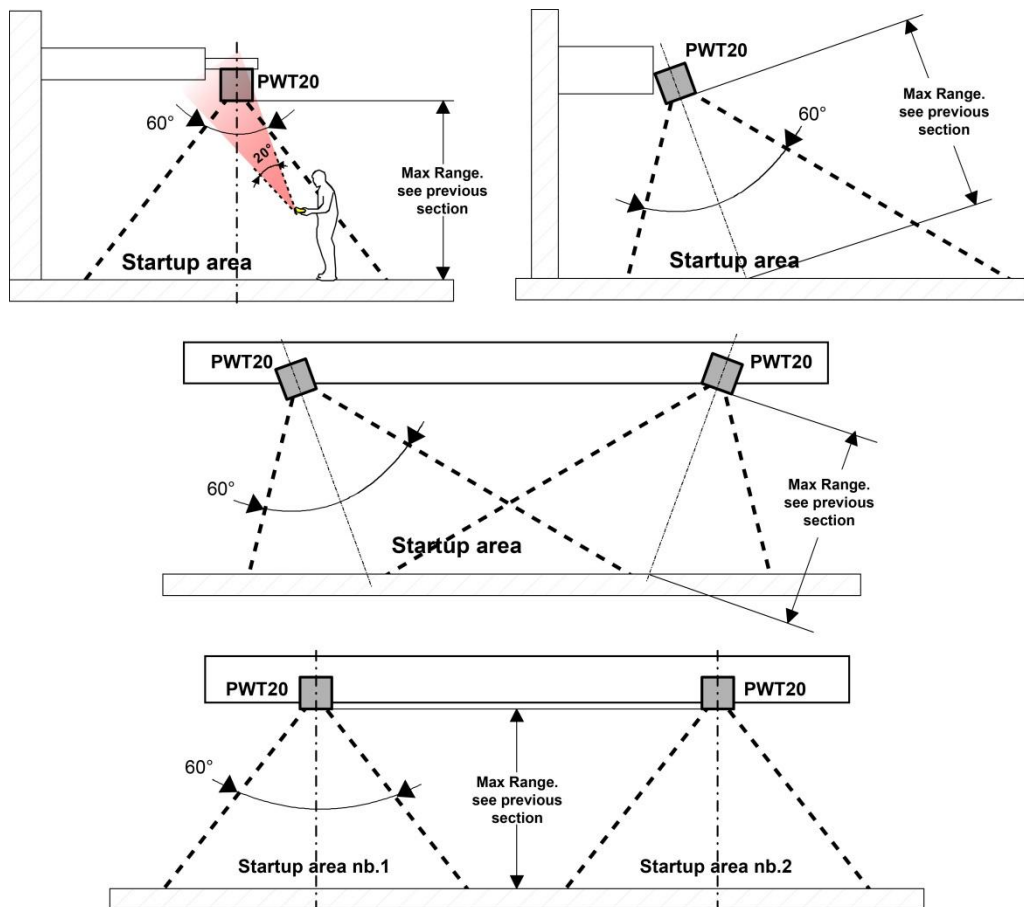

7.2 "Area limitation by IR" function

This function makes it possible to condition commands (start-up, movement ...) according to the physical position of the operator equipped with the transmitter.

Examples:

- Start a crusher if the operator is on a platform,
- Unfold the stabilizing arms of a truck if the operator is in sight of the arms.

The zone (s) from which the commands are authorized are covered by one or more infrared cells.

The infrared signal emitted by the transmitter must be received by one of the cells for the command to be authorized.

However, it is possible to temporize the momentary absence of the operator in the infrared detection field (setting with the **iDialog** software).

With the **Timo** or **Nemo** Receivers, it is possible to create 2 groups of IR cells and to condition commands according to the infrared signal received by one of the cells of group 1 or group 2.

Example:

- Group 1 cells condition the stabilizer controls on the right side.
- Group 2 cells condition the controls of the left stabilizers.

7.3 "Association and selection by infrared" function

This function is strongly recommended when several identical equipments (wagons, drilling heads, overhead cranes, handling trucks, conveyors, trailers ...) are available to one or more operators.

Each operator can, by the IR (infrared) of his transmitter, select the equipment that he wants to control (receiver).

- It is no longer necessary to have a transmitter for each device and it is no longer necessary to change the transmitter when changing equipment.
- Each device must be equipped with a receiver and one or more IR cells.
- Several operators can simultaneously select and associate with a different receiver.
- A configuration menu allows the user to choose the radio channel. This channel is transmitted during infrared association.
- A selected / associated device (receiver) remains under the control of the operator who selected it until it has been "released".
- The release of a receiver results either from a stop (push button on the transmitter) or from a power failure.

Note: This function is not accessible when the receiver is configured with a cable link

7.4 Cable link between Transmitter / Receiver

NOTE: When using the cable link option, the Transmitter is powered by its battery.



**Operator module
Pika / Moka :**



male C16 connector

**Transceiver module
Alto / Timo / Nemo :**



female C16 connector

The connection points between the transmitter and the receiver are compatible pin to pin:

C16 connector pins	C16 connector Transmitter Pika / Moka	C16 connector Receiver module Alto / Timo / Nemo
1	1	1
2	2	2
3	3	3
4	4	4
5	5	5
6	shielding	shielding
7	/	/

7.5 "Tandem synchronised command" function

This function allows to control two equipments with a single Transmitter. The control of the two Receivers can be synchronized or not.

A product solution with this function is composed of:

- 1 Transmitter (specially configured for the "synchronized control" function)
- 2 Receivers

Note 1: It is possible with this function to have a « *live signal* » transmitted by radio between the two Receivers to secure the two Receivers, in case of security of one or the other receivers following a passive stop. In case of failure, both MT will stop in 2069ms max. The time between the first MT stop and the second MT stop will not exceed 1169ms.



The life signal can only be set by iDialog. Please check the iDialog user manual to know how to use the life signal.

Note 2: This function is not accessible when the receiver is configured with a cable link

7.5.1 Operating principle

The products can work in different ways:

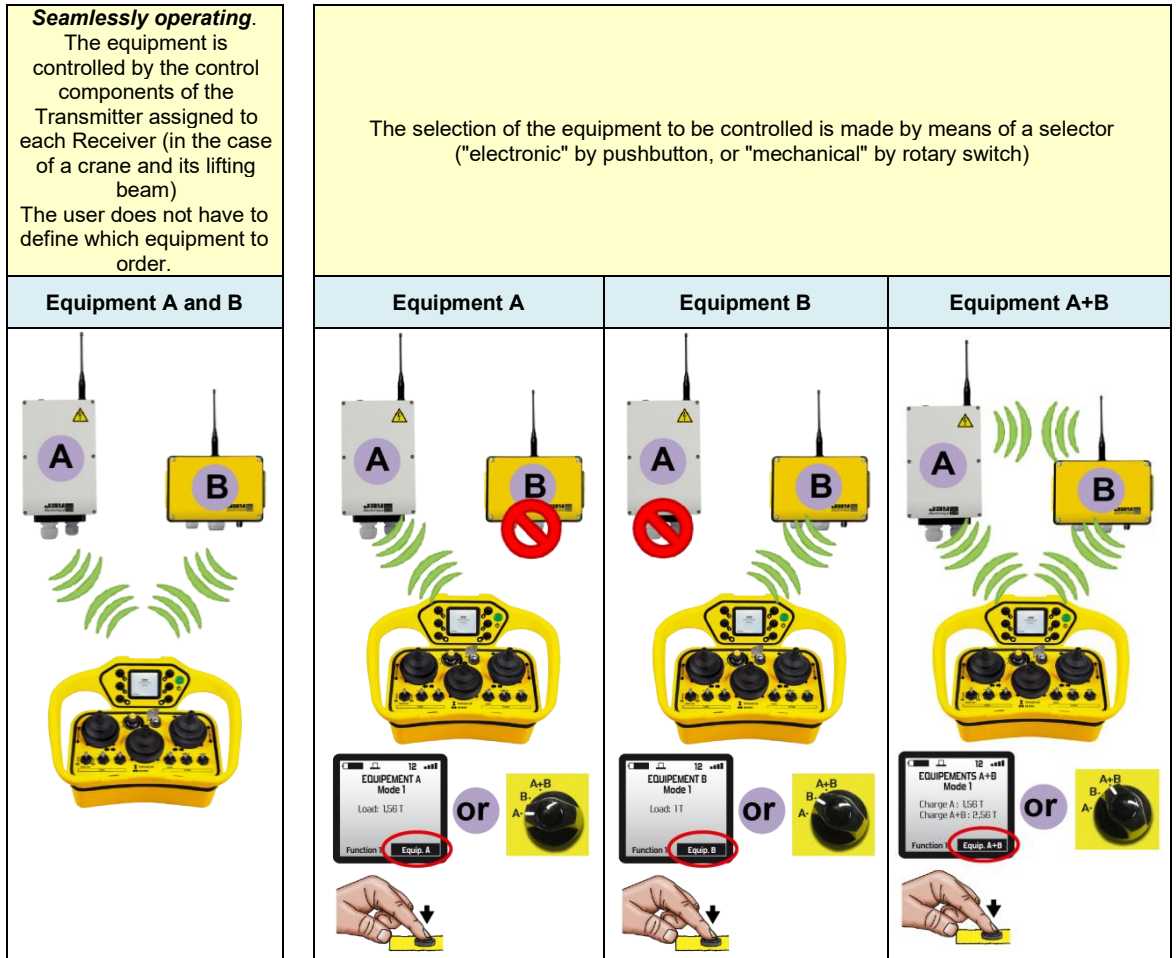

In the coupled DUO mode (**A + B**), the 2 Receivers can exchange the status of limit switches and sensors (up to 16 on-off information and 1 analog information) as well as the status of their safety relays.

Note: If one of the two receivers do not respond in the start phase, only the receiver that responded to the start request will be active.

7.5.2 Use

During use: Examples of information feedback on the transmitter screen (2 travelling cranes: 3T and 5T):

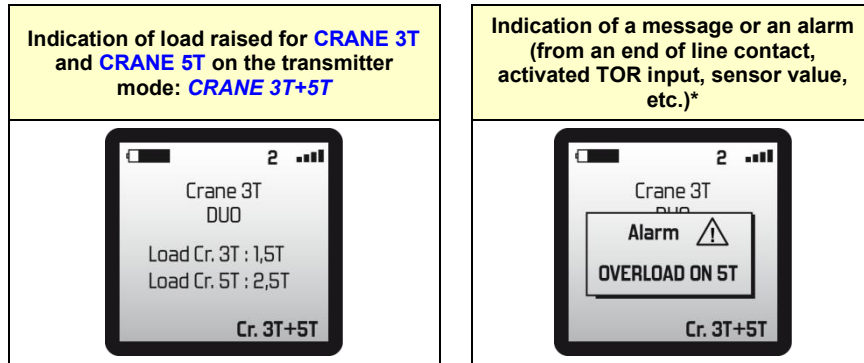



* = can be changed with the programming software **iDialog**

7.5.3 System Shutdown

After pressing the stop button on the Transmitter, the Receivers are automatically "released". The system can be started again.

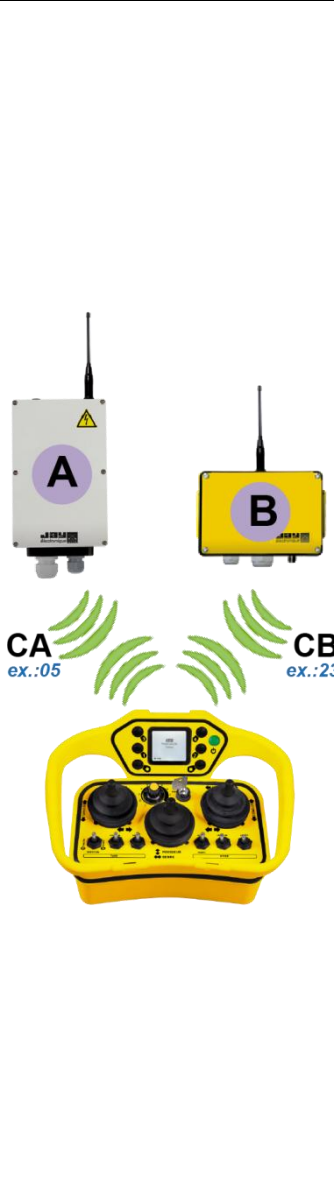
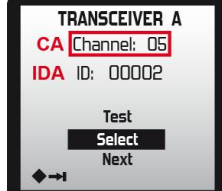
7.5.4 Associating the Transmitter with Receivers

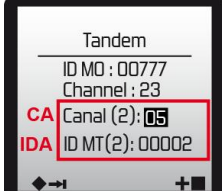
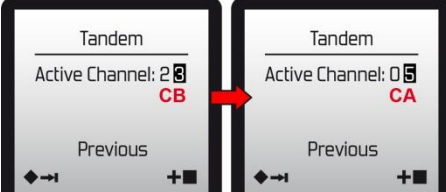
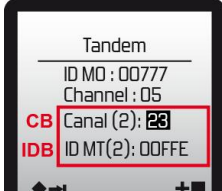
	<p>1. Associate the Transmitter with Receiver A, note the working radio channel CA and the IDA code (see chapter 4.5 "Learning function")</p>		
	<p>2. Associate the Transmitter with Receiver B, note the working radio channel CB and the IDB code. (see chapter 4.5 "Learning function")</p>		
	<p>3. Indicate the working radio channel CA and the IDA code to Receiver B. Go to the menu: Setup / Radio / Tandem / Settings</p>		
	<p>4. Then, select the radio channel used to communicate to Receiver A to finalize the association. Go to the menu: Setup / Radio / Tandem / Selection</p>		
	<p>5. Indicate the working radio channel CB and the IDB code to Receiver A. Aller dans le menu: Go to the menu: Setup / Radio / Tandem / Settings</p>		
	<p>6. Press the safety stop palmswitch on the transmitter</p>		
	<p>7. Wait for twenty seconds before starting the transmitter</p>	<p style="text-align: center;">The association procedure is completed</p>	

7.5.5 Changing the radio channel on a Receiver

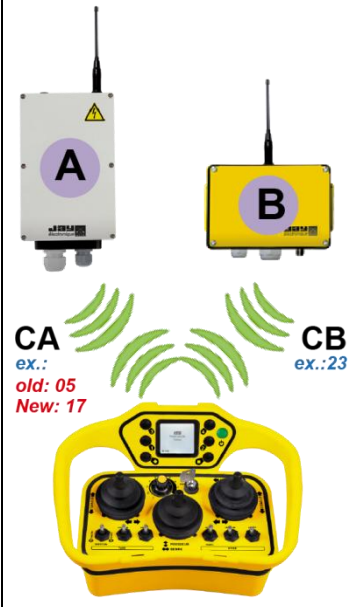

CA
ex.:
old: 05
New: 17

CB
ex.: 23

1. If not already done, select the radio channel you wish to add. right hereReceiver **A**
Go to the menu: **Setup / Radio / Tandem / Selection**

Tandem

Active Channel: 0**5**

CA

Previous

◀ → + ▢

2. Modify the active working channel with Receiver **A** in the menu **Setup / Radio / Tandem / Settings**

Tandem

ID MO : 00777

CA Active channel: 0**5**

CB Canal (2): 23

ID MT(2): 00FFE

Previous

◀ → + ▢

Tandem

ID MO : 00777

CA Active channel: 1**7**

CB Canal (2): 23

ID MT(2): 00FFE

Previous

◀ → + ▢

3. Then select the radio channel used to communicate with the Receiver **B**
Go to the menu: **Setup / Radio / Tandem / Selection**

Tandem

Active Channel: 1**7**

CA

Previous

◀ → + ▢

Tandem

Active Channel: 2**3**

CB

Previous

◀ → + ▢

4. Enter the new radio channel **CA** at Receiver **B**
Go to the menu: **Setup / Radio / Tandem / Settings**

Tandem

ID MO : 00777

CB Active channel: 23

CA Canal (2): 0**5**

ID MT(2): 00002

Previous

◀ → + ▢

Tandem

ID MO : 00777

CB Active channel: 23

CA Canal (2): 1**7**

ID MT(2): 00002

Previous

◀ → + ▢

5. Press the safety stop palmswitch on the transmitter
6. Wait for twenty seconds before starting the transmitter

The radio channel change procedure on Receiver **A** is completed

7.6 "Master – Master synchronised command" function

This function enables one to control two items of equipment in a synchronised manner. The movements made by the items of equipment will be from a single transmitter.

A solution produced with this function comprises:

- **2 transmitters** (Either Beta/Gamma or Pika/Moka type, it is not possible to mix Transmitters with buttons and Joysticks in DUO mode)
- **2 Receivers**

Note 1: It is possible with this function to have « *life signal* » transmitted by radio between the two Receivers to secure the two Receivers, in case of security of one or the other receivers following a passive stop. In case of failure, both MT will stop in 2069ms max. The time between the first MT stop and the second MT stop will not exceed 1169ms.



The life signal can only be set by IDialog. Please check the IDialog user manual to know how to use the life signal.

Note 2: This function is not accessible when the receiver is configured with a cable link.

7.6.1 Operating principle



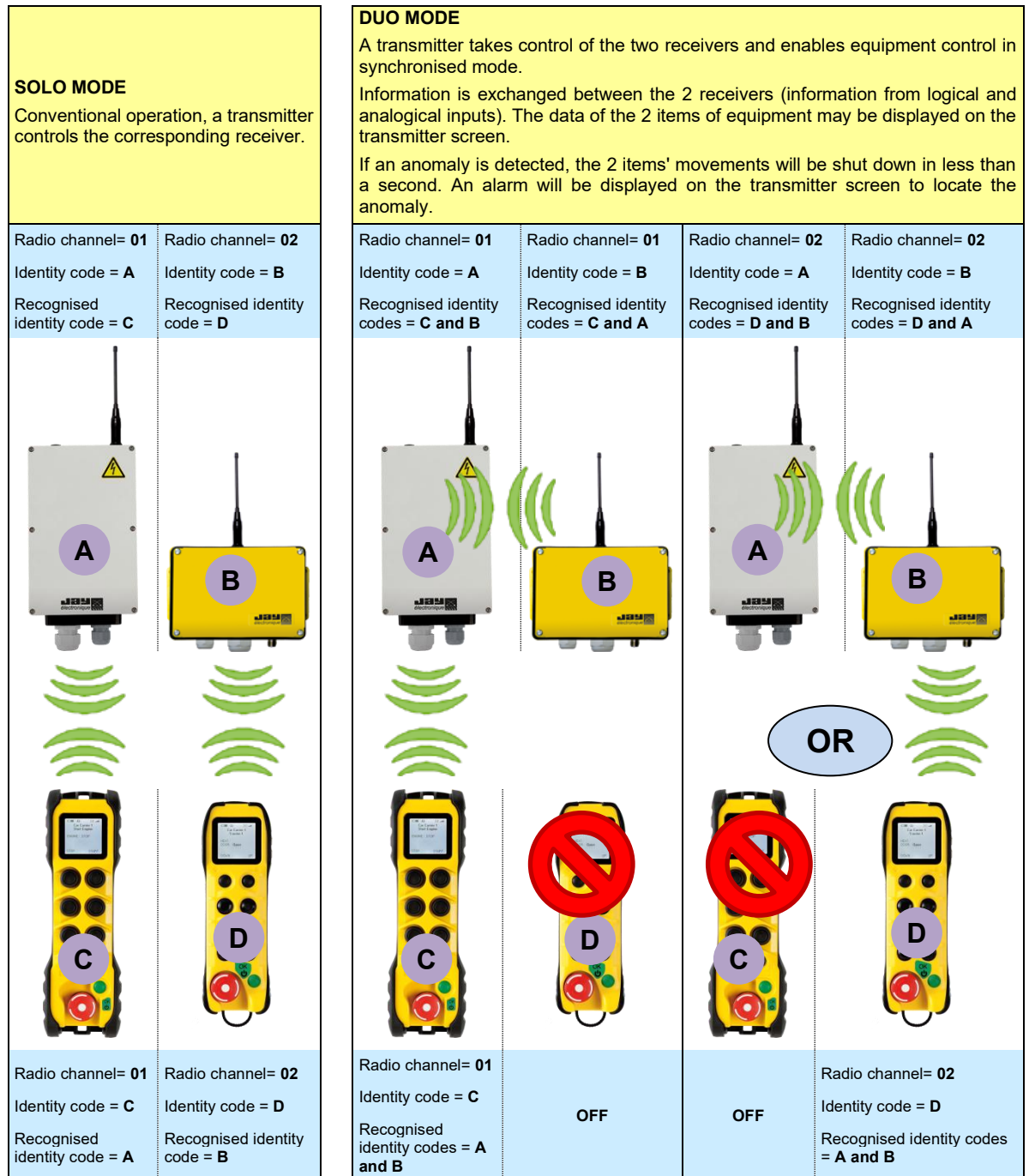

The products may operate together in **3 different ways**. An operating mode is selected **when the transmitters start up**:



In the coupled DUO mode (**A + B**), the 2 Receivers can exchange the status of limit switches and sensors (up to 16 on-off information and 1 analog information) as well as the status of their safety relays.

7.6.2 Use

Examples of possible ways of starting transmitters:

<p>Operating mode selection screen:</p>	<p>This screen indicates that DUO mode is not accessible (the 2nd Receiver is used in SOLO mode or has not been released by the other transmitter):</p>	<p>Possibility of blocking access to coupling for one of the two transmitters. Setup / Function / Master-Slave menu</p>
		
<p> If one of the two receivers is unavailable (already used by another transmitter), the following message will appear:</p>		
		

During use: Examples of information feedback on the transmitter screen

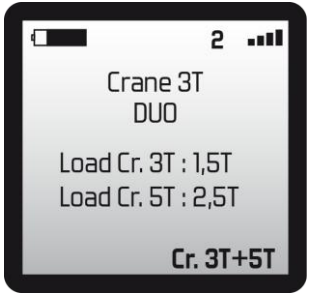
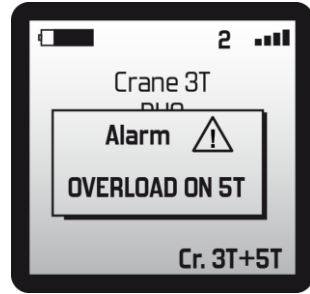
<p>Indication of load raised for CRANE 3T and CRANE 5T on the transmitter in DUO mode</p>	<p>Indication of a message or an alarm (from an end of line contact, activated TOR input, sensor value, etc.)*</p>
	

* = can be changed with the programming software **iDialog**

7.6.3 Change to operating mode and system shutdown

A mode change selection (**DUO** or **SOLO**) can be made each time the products start up.

Release of a Receiver when the system is shut down:

A receiver can be released automatically after a shutdown or by a voluntarily order. The choice of a voluntary release can be set using the **iDialog** programming software.

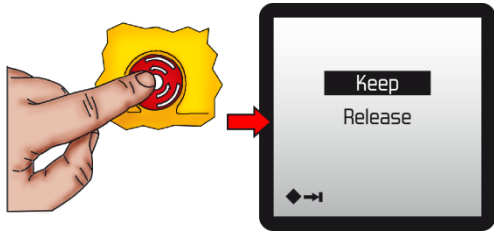

7.6.4 Procedure for associating Transmitters / Receivers

Products with the "**synchronised command**" function are delivered already configured and associated.

However, it may be necessary to create an association again, if a product is replaced for example.

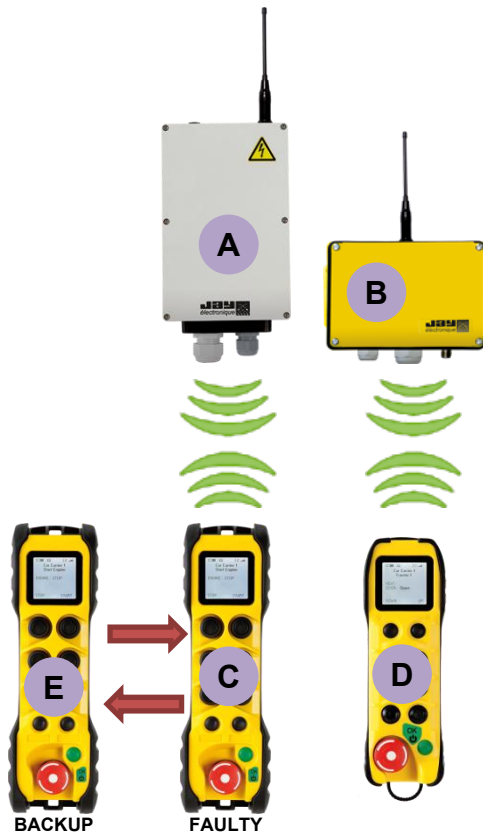

1. Follow the procedure for association between Transmitter **E** and Receiver **A** described in chapter [4.5 "Learning" function](#).

For each of the transmitters, go to the menu: **Setup / Radio / Master-Slave / Settings**

2. Configure the backup Transmitter **E** by copying the identity code and radio channel information used by the Transmitter **D** and the Receiver **B** id code.
3. Confirm by pressing the green "validate" pushbutton.
4. Configure the Transmitter **D** by copying the identity code and radio channel information used by the backup Transmitter **E** and the Receiver **A** id code.
5. Confirm by pressing the green "validate" pushbutton.

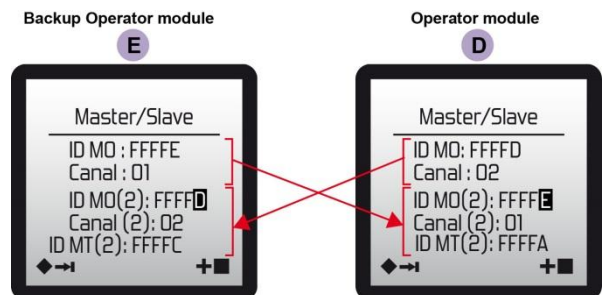

6. Press the safety stop palmswitch on the 2 transmitters.
7. Wait for twenty seconds before starting the transmitter(s)

The association procedure is complete.

7.6.5 Procedure to change radio channel

Prerequisites:

Unless the "Transmitters and Receivers" assembly is configured in **automatic release** mode, both receivers must be released.

To do so, the receivers must be on, press the "Master" Transmitter stop palmswitch and validate the choice "Release" by pressing the green "validate" pushbutton.

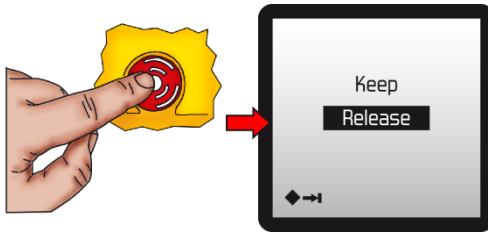

Example changing a radio channel on one of the two transmitters:

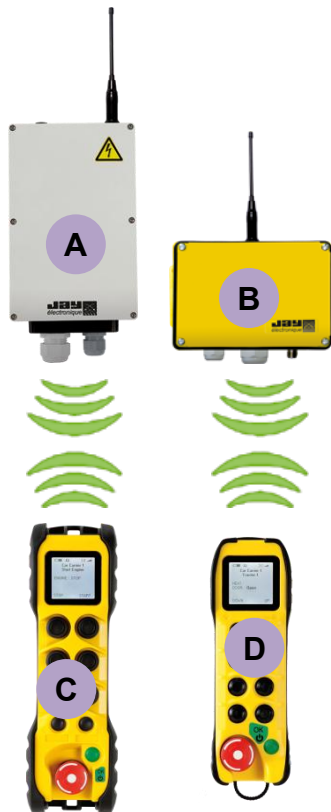

1. On the 2 transmitters, access the **Setup / Radio / Master/Slave / Settings** menu
2. On transmitter **C**, change the **Active Channel**
3. Confirm by pressing the green "validate" pushbutton.
4. On transmitter **D**, change the **Channel (2)**
5. Confirm by pressing the green "validate" pushbutton.

E.g. changing the radio channel on the transmitter C, radio channel no. 34 instead of no.22:

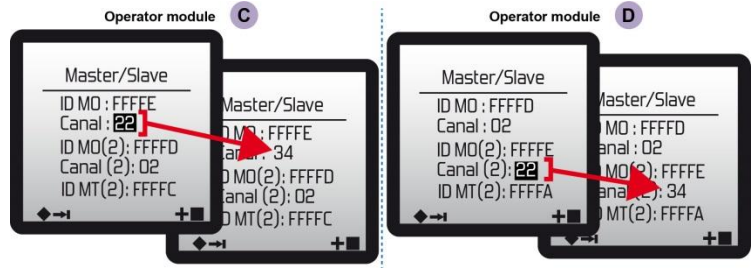

6. Press the safety stop palmswitch on the 2 transmitters.
7. Wait for twenty seconds before starting the transmitter(s)

The radio frequency changing procedure is complete.

7.6.6 Compatibility with "Start up by infrared validation" option

This option is compatible with the "Master-Master synchronised command" function.

To start the system, both in **SOLO** mode and in **DUO** mode, the transmitter must be pointing towards the IR cell on the associated Receiver:

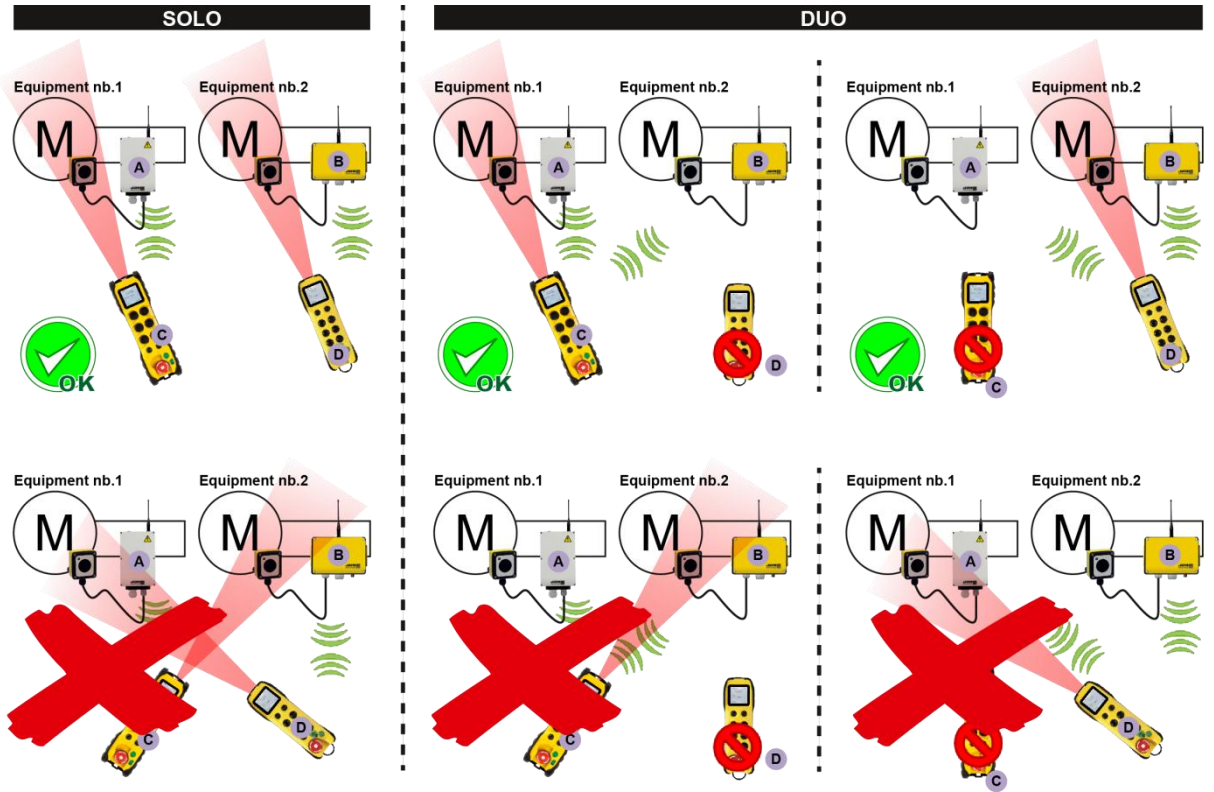

7.7 “Pitch & catch 2.0” function

This function allows to manage:

- Alternately from **2 up to 20 Transmitters** (20 Operators) *
- With **1 Receiver** (1 equipment).

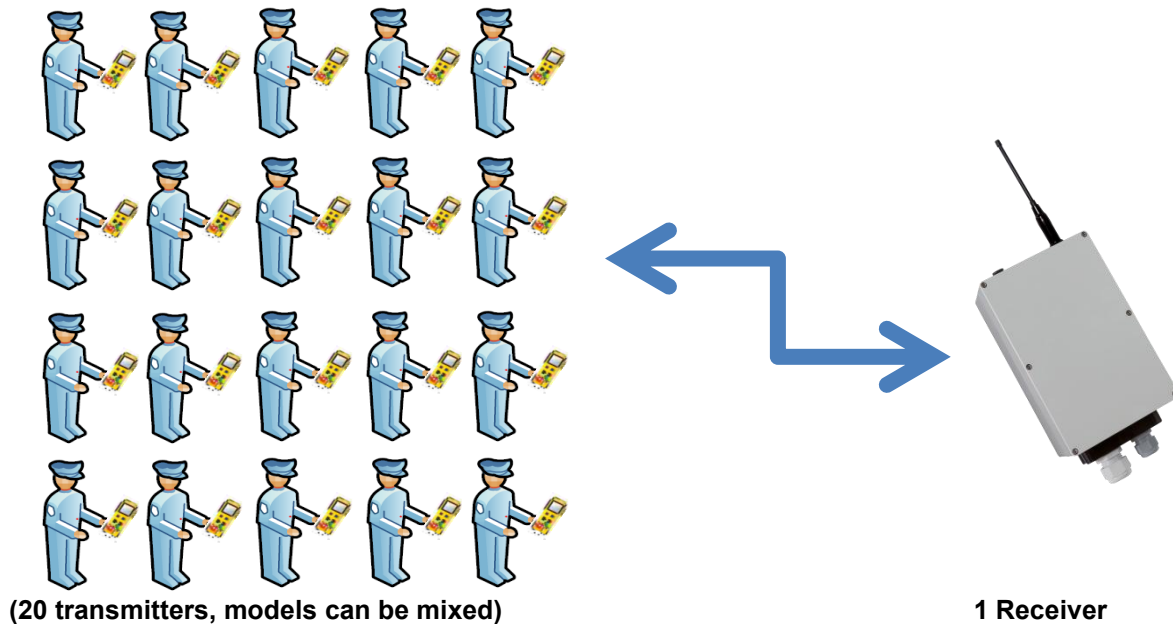

Note 1: The functions (start by IR enable, Multimodes 3 to 32 ...) are compatible with the Pitch & Catch 2.0 function

*= The number of Transmitters can be set with the **iDialog** software, see the following chapter **“Configuration”**.

7.7.1 Operating principle

The Receiver is radio-controlled by one Transmitter at a time.

When an equipment is controlled by an operator, the other operators must wait for the **release** (availability) of the equipment to take control.

All the Transmitters operate on the same radio.

7.7.2 Use

The use of the Receiver can only be done with **one Transmitter at a time**.

The Receiver is starting in the normal way. However, if the Receiver is already used by a Transmitter or has not been **“Released”** at the end of a previous use, the following message appears on the Transmitter screen:

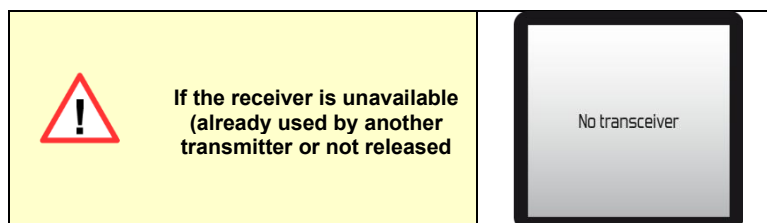

7.7.3 System shutdown (and release)

After pressing the stop button on the Transmitter, the Receiver can be released either **automatically*** or **manually***:

"Automatic release": Generally, the equipment is released as soon as the radio connection is interrupted. Another transmitter can then immediately start the Receiver.

"Manual release": For applications where safety must be reinforced, the equipment can be released by a voluntary action of the operator (eg combination of buttons etc ...). Another transmitter will not be able to start the Receiver until it has been "released".

* = The « release mode » is configurable with **iDialog** programming software

7.7.4 Configuration

The configuration of the Pitch and Catch function is performed using the **iDialog** software, menu **Use parameter / Synchronized control**

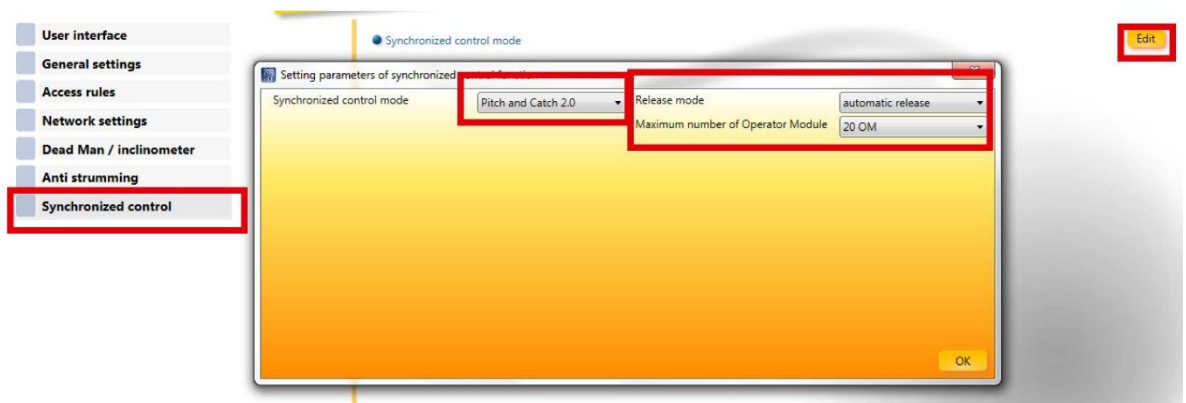

Release Mode: Automatic or Manual

Maximum number of Transmitter: Enter the number of Transmitters that will drive the Receiver sequentially (max 20).

The information associated with this operating mode is displayed by a logo in **Setup / Radio** menu.

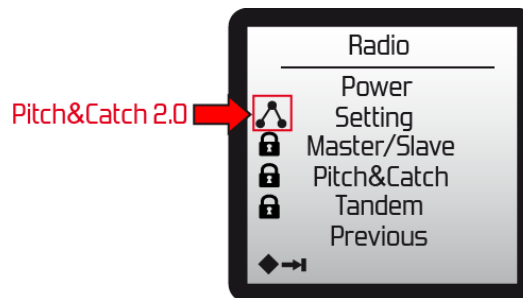

7.7.5 Associating a Transmitter with the Receiver

The procedure for associating Transmitters is the same as for a standard association.

Each Transmitter must be associated one by one with the Receiver (see section **4.5 "Association" function (association with a Receiver)**).

7.7.6 Changing the radio channel

Take one of the Transmitters and apply the radio channel change procedure of a standard solution.

For the other Transmitters already associated with the Receiver, make a start and wait until they find the new radio channel.

7.7.7 Replacing a Transmitter (backup model)

Same procedure as with standard solution (Transmitter / Standard Receiver association procedure).

Note: The new Transmitter will take the place of the one whose use is the oldest.
In case of doubt, start by starting alternately all the transmitters to keep.

7.7.8 Replacing the Receiver

Same procedure as with standard solution.

The Transmitter / Receiver combination must be performed for each Transmitter.

7.8 “Pick & Control 2.0” function

The “Pick & Control 2.0” function allows transmitters to select 1 receiver from a maximum of 32.

This function requires some prerequisites, namely:

- **Receivers must be equipped with the same configuration sheet and a TOR entry or infrared.**
- For each transmitter, the operating channel must be different from the rest channel.
If several transmitters are devoted to be used simultaneously, their operating channel must be different.
(See chapter §7.8.5)
- The ELIO receiver must be equipped with its extension board.

The flowchart below describes the procedure to be executed to configure this function:

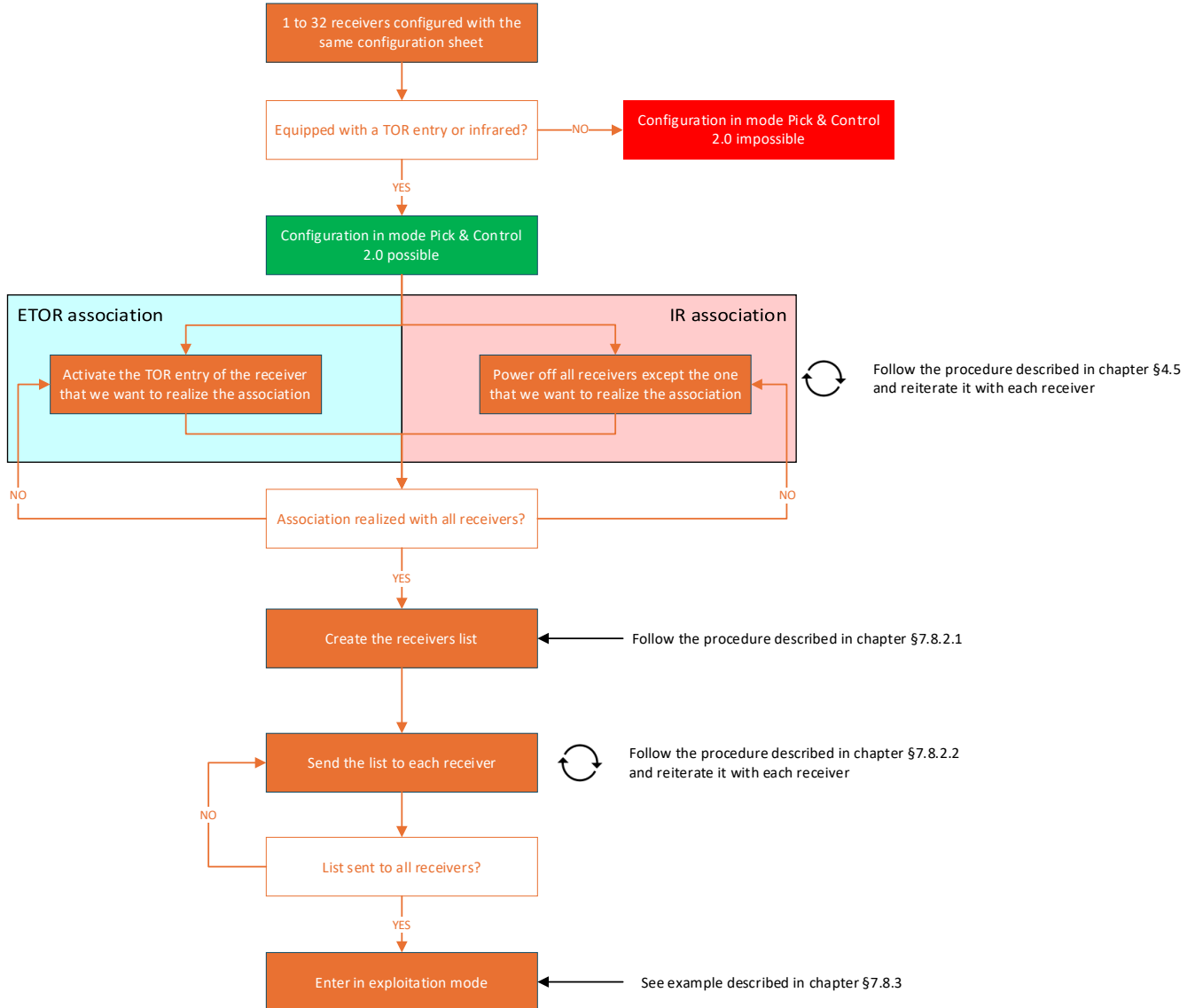

7.8.1 Association in “Pick & Control 2.0”

The association phase is used to retrieve the configuration sheet and the different HMI on the transmitter and to teach the transmitter identity code to the various receivers configured in “Pick & Control 2.0”.

The association in “Pick & control 2.0” is performed as described in the chapter [4.5 “Association” function \(association with a Receiver\)](#).

To select one specific receiver and realize the association with it, a target discriminator must be used.

This discriminator is declined under the two following conditions:

- **TOR entry as target discriminator:**
If the receiver is configured with a TOR entry, the TOR entry of the targeted receiver must be activated. Only the receiver with the active TOR entry will answer on the rest channel.
 - **The receiver TOR entry must be maintained active during the receiver selection until the transfer starts.**
- **IR as target discriminator:**
If the receiver is configured in infrared, all receivers except the targeted one must be powered off. The receiver we want to make the association with will be found on the rest channel.



For each step described thereafter, the TOR / IR target discriminator must be used in order to select the targeted receiver.



To avoid a user performing an association, the association can be protected by a PIN code. The PIN code can be defined via **iDialog**

7.8.2 Creation and modification of the list

Once all receivers have been associated, the list containing all receivers identity codes that can be used by a transmitter must be created.



This list is created using the “List” menu.

In this menu, it is possible:

- To add one or several receivers (*principal usecase here for the “Pick & Control 2.0” deployment*),
- To replace a receiver present inside the list by another one,
- And to remove a receiver from the list.

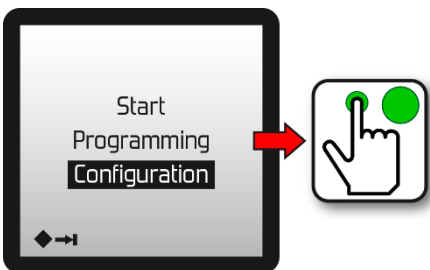
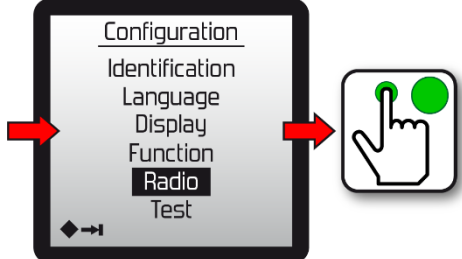
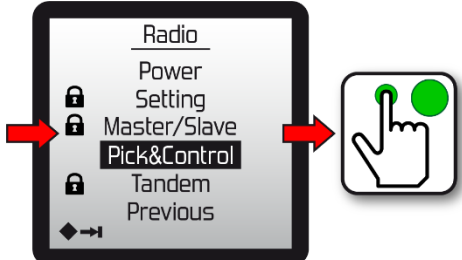
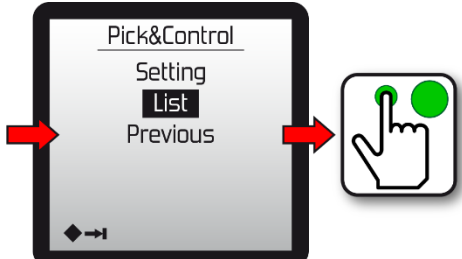
To access the "List" menu, complete the following steps:

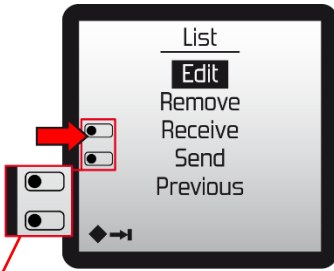
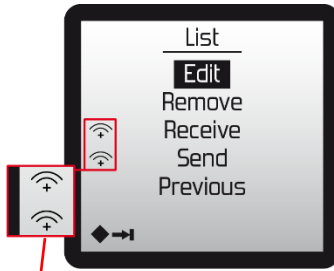
Home	
Configuration menu	
Radio menu	
Pick & Control menu	

List menu	<div style="display: flex; justify-content: space-around; align-items: flex-start;"> <div style="text-align: center;">  <p>Indicates that the products are configured with the digital input as the target discriminator.</p> </div> <div style="text-align: center;">  <p>Indicates that the products are configured with the infra-red as the target discriminator.</p> </div> </div> <div style="text-align: center; margin-top: 20px;">  <p>In Infrared configuration, please make sure to select the good MT. Please check the chapter §7.1 to know how to select an MT with infrared.</p> </div>
-----------	--







To avoid a user can change the list, the configuration menu can be protected by a PIN code. The PIN code can be defined via *iDialog*.

7.8.2.1 “Edit” menu

The “Edit” menu allows to add, replace or remove a receiver from the list. The maximum number of receivers that can be part of the list is fixed to 32.

The “Edit” menu provides the different options detailed in the table below:

<p>R = Record: Allow to record a receiver in an empty slot of the list or replace one.</p>	<div data-bbox="975 284 1240 510" style="border: 1px solid black; padding: 5px; text-align: center;"> Edit 01  Identity code MT: 00111 </div>
<p>Bin: Allow to remove a receiver.</p>	<div data-bbox="975 517 1240 739" style="border: 1px solid black; padding: 5px; text-align: center;"> Edit 01  Identity code MT: 00111 </div>
<p>Right arrow: Allow to navigate in ascending order.</p>	<div data-bbox="975 745 1240 967" style="border: 1px solid black; padding: 5px; text-align: center;"> Edit 01  Identity code MT: 00111 </div>
<p>Left arrow: Allow to navigate in descending order.</p>	<div data-bbox="975 974 1240 1193" style="border: 1px solid black; padding: 5px; text-align: center;"> Edit 01  Identity code MT: 00111 </div>

Add of a new receiver:

Select the concerned receiver using the target discriminator then push the “On” button  to record its identity code. The receiver below is configured in TOR entry.



Position of the target in the list.

R: Record: allows a target on the list to be replaced / added.



Identity code of the receiver module that has been added.



Please make sur that the IDcode is the ID code of the wanted MT



Activation of an alarm:

During the record, a warning message may be displayed. This means that it could not be performed (the receiver module did not answer (powered off) or the transmitter did not receive a response (radio perturbation)).



Remark: This warning message can be deleted by pushing the transmitter “On” button .



Allow the user to navigate within the list by pressing the green button. The right arrow  allows the user to move in ascending order while the left arrow  can be used to move in descending order. The selection can be changed using the navigation button.

Identity code of the receiver in position 1 on the list.



Please make sur that the IDcode is the ID code of the wanted MT



When the “list” is completed, please check the list of MT and the position in the list to make sur that the installation is good. To check the list, please check chapter [\\$4.8.3.3 Tables](#).

7.8.2.2 “Send” menu

Once the list is created, it must be exported to all concerned receivers using the “Send” menu. To do this, the chosen receiver must be selected using the target discriminator. (See chapter §7.8.1)



 It is highly recommended to make sure that the list created has been sent to all receivers so that they know each other. This will facilitate the list transfer from one transmitter to another one, using any of the 32 receivers, following the dedicated procedure. (See chapter §7.8.6)

7.8.2.3 “Receive” menu

The “Load” menu allows to import on a transmitter a list contained on a receiver. To do this, the chosen receiver must be selected using the target discriminator. (See chapter §7.8.1)





 This menu is used for a transmitter replacement or to retrieve the list contained in a receiver if it has been accidentally deleted from the transmitter.

7.8.2.4 “Remove” menu

The “delete” menu allows to delete the list contained in a transmitter.



 This menu deletes the list contained in a transmitter without confirmation request. If the list is deleted, a new one must be created following the “Change” procedure described in chapter §7.8.2.1 or by charging the list contained in a receiver using the “Load” option following the procedure described in chapter §7.8.2.3. Use this option only in case of high necessity, otherwise use the delete option (bin pictogram ) from the “Change” procedure described in chapter §7.8.2.1.

7.8.3 Exploitation

Now, knowing that the receivers list has been created at the previous step following procedure described in chapter §7.8.2, it only needs to enter in exploitation mode in order to control each receiver separately from a maximum of 32 as shown in the following picture:

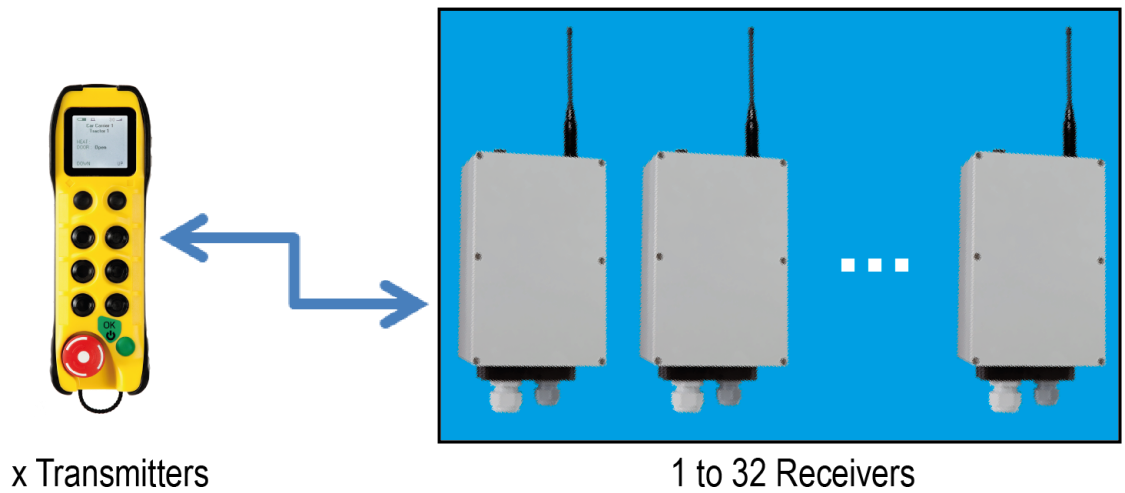

If the previous step regarding the list creation has not been performed, please refer to and perform it because entering in exploitation mode will not be possible without this beforehand configuration.

A configuration example achievable using the “Pick & Control 2.0” function is detailed on the next page.

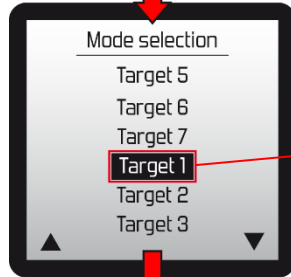
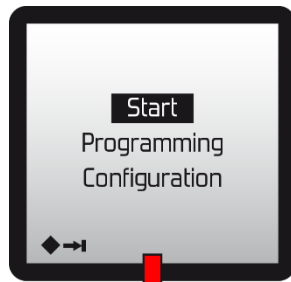

“Target” corresponds to the name of the operating mode.

“1” corresponds to the operating mode number. An operating mode corresponds to a receiver module.

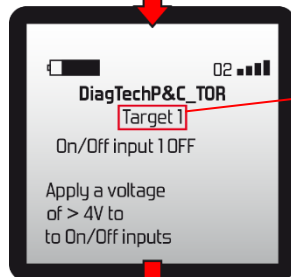

Target 1 has been selected on the list.

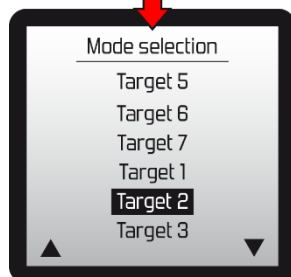

The list can be displayed using the navigation button defined in **iDialog** to use a different receiver module. Displaying the menu stops the exploitation of the current receiver. The max. number of receiver modules available in the list is defined in **iDialog**.

Note: Only one receiver can be managed at a time by a same transmitter.

If the selected target is unavailable (missing or already used by another transmitter), the following message is displayed:



7.8.4 Exploitation stop

Several events can lead to an exploitation stop. These events are listed below.

Transmitter side:

- The operator triggers the emergency stop of the transmitter.
- The operator changes of target receiver.

Receiver side:

- When a receiver leaves the “exploitation” mode for the “safe” mode, it changes its radio channel from the operating channel to the rest channel and is available in the group of receivers at rest.

Exploitation stop of Receiver x

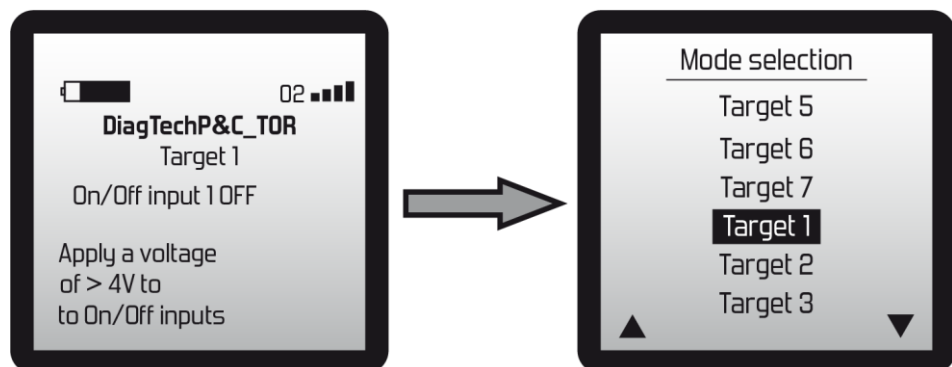

7.8.5 Rest channel and operating channel

The rest channel is fixed by the configuration sheet and cannot be changed from the transmitter. It is the channel on which all receivers are in listening mode when they are not in exploitation.

The operating channel (active channel) must be different from the rest channel and can be changed from the transmitter. It is the channel on which the transmitter controls the receivers in exploitation.

If several transmitters are used at the same time within the park, their associated operating channels must be different.



Rest channel: All receivers within the park are in listening mode on this channel until the start of exploitation.

Operating channel: This channel must be different on each transmitter. This is the channel used in exploitation.



If there is multiple system (different park of MTs) configured in “Pick and control 2.0” make sure that the “rest channel” is different from the other park of MT. The “Rest channel” can be configured by iDialog.

7.8.6 List transfert from transmitter to transmitter

The lists can easily be transferred from one transmitter to another one using the “Send” and “Receive” functions.

To transfer a list from one transmitter to another one, the following steps must be completed:

- Associate the spare transmitter with all receivers following the procedure described in chapter §7.8.1,
- Start the transmitter containing the list we want to transfer,
- Send the list to a referent receiver using the “Send” function following the procedure described in chapter §7.8.2.2,
- Start the spare transmitter that needs to retrieve the list,
- Retrieve the list contained in the receiver using the “Receive” function following the procedure described in chapter §7.8.2.3,
- Finally, both transmitters own the same receivers list.

7.9 “MultiDevices” function

The function “MultiDevices” allows a transmitter to select and control several receivers simultaneously (until a maximum of 8 receivers).

This function requires some prerequisites, namely:

- Receivers must be equipped with the same configuration sheet and a TOR entry.
- For each transmitter, the operating channel must be different from the rest channel.
If several transmitters are devoted to be used simultaneously, their operating channel must be different. (See chapter §7.8.5)
- The ELIO receiver must be equipped with its extension board.

The flowchart below describes the procedure to be executed to configure this function:

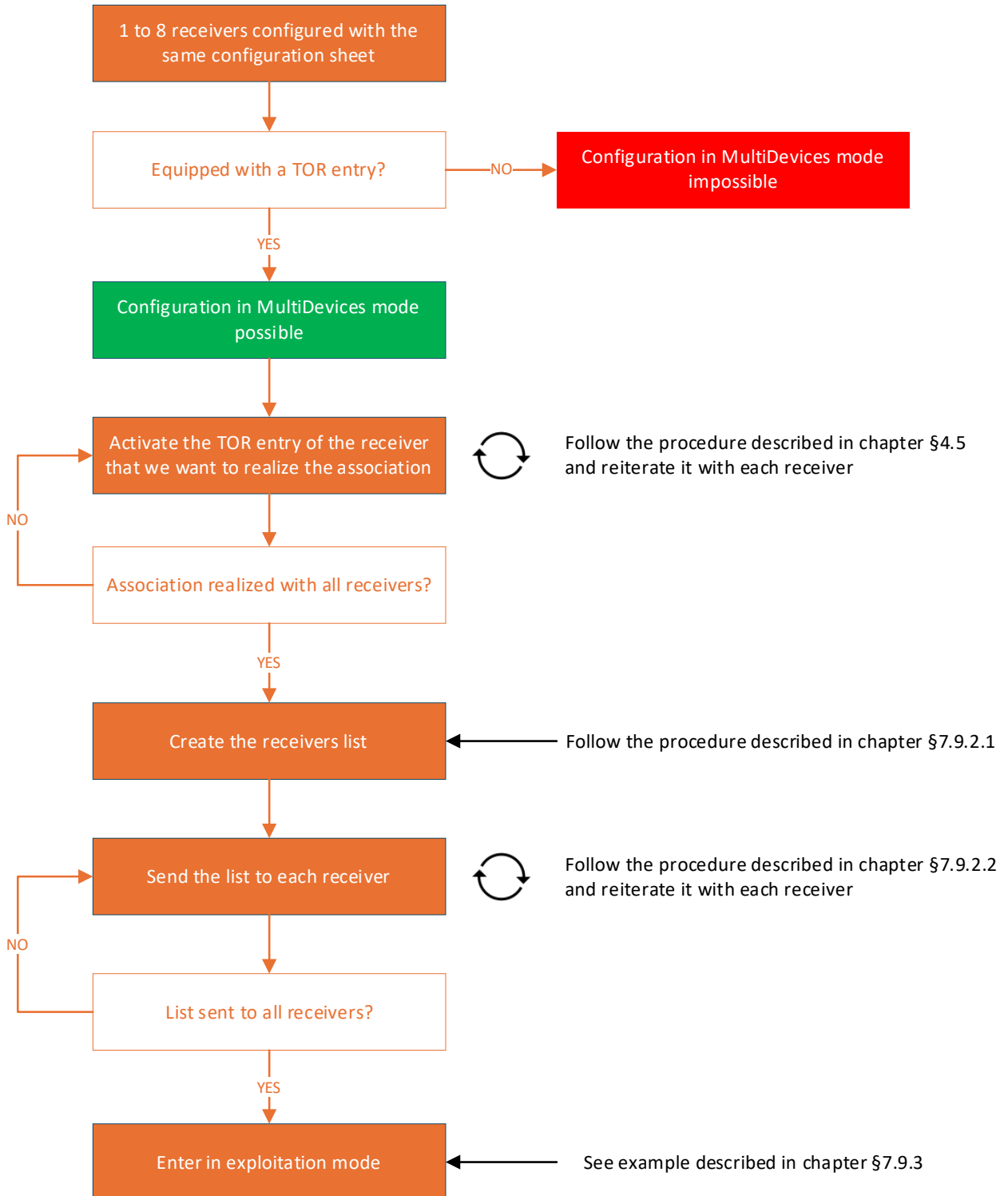

7.9.1 Association in “MultiDevices”

The association phase is used to retrieve the configuration sheet and the different HMI on the transmitter and teach the transmitter identity code to the various receivers configured in “Pick & Control 2.0”.

The association in “MultiDevices” is performed as described in **chapter 4.5 “Association” function (association with a Receiver)**.

To select one specific receiver and realize the association with it, a target discriminator must be used. This discriminator is declined under the following condition:

- TOR entry as target discriminator:
Only the receiver with the active TOR entry will answer on the rest channel.
 - **The receiver TOR entry must be maintained active during the receiver selection until the transfer starts.**



For each step described thereafter, the TOR target discriminator must be used in order to select the targeted receiver.



To avoid a user performing an association, the association can be protected by a PIN code. The PIN code can be defined via **iDialog**.

7.9.2 Creation and modification of the list

Once all receivers have been associated, the list containing all receivers identity codes that can be used by a transmitter must be created.

This list is created using the “List” menu.

In this menu, it is possible:

- To add one or several receivers (principal usecase here for the “MultiDevices” deployment),
- To replace a receiver present inside the list by another one,
- And to remove a receiver from the list.

To access the "List" menu, complete the following steps:

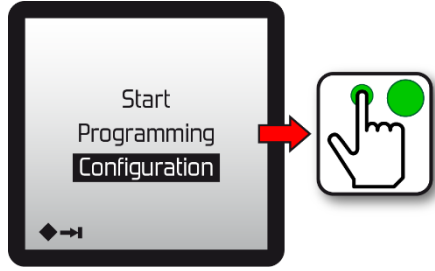
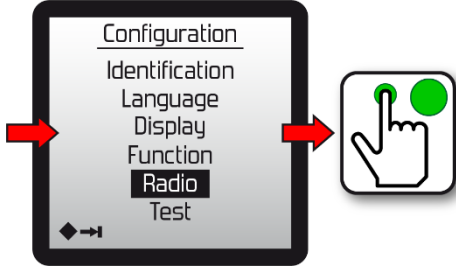
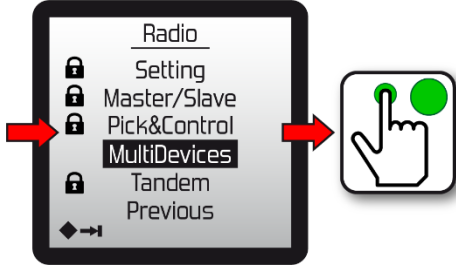
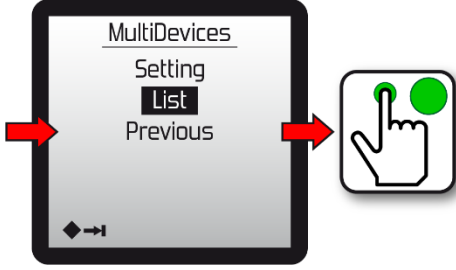
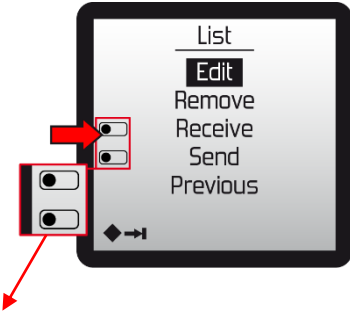
<p>Home</p>	
<p>Configuration menu</p>	
<p>Radio menu</p>	
<p>MultiDevices menu</p>	
<p>List menu</p>	 <p>Indicates that the products are configured with the digital input as the target discriminator.</p>







To avoid a user can change the list, the configuration menu can be protected by a PIN code. The PIN code can be defined via *iDialog*.

7.9.2.1 “Edit” menu

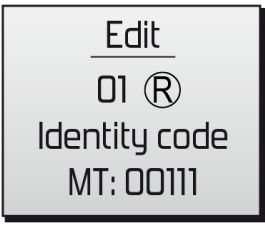
The “Edit” menu allows to add, replace or remove a receiver from the list. The maximum number of receivers that can be part of the list is fixed to 8.

The “Edit” menu provides the different options detailed in the table below:

R = Record: Allow to record a receiver in a empty slot of the list or replace one.	
Bin: Allow to remove a receiver.	
Right arrow: Allow to navigate in ascending order.	
Left arrow: Allow to navigate in descending order.	

Add of a new receiver:

Select the concerned receiver using the target discriminator then push the “On” button  to record its identity code.



Target position in the list.

R: Record: Allow to replace a target from the list.



Identity code of the receiver that has been added.



Please make sure that the ID Code corresponds to the one of the receiver wanted.



Activation of an alarm:

During record, a warning message may be displayed. This means that it could not be performed (the receiver did not answer (powered off) or the transmitter did not receive a response (radio perturbation)).



Remark: This warning message can be deleted by pushing the “On” button  on the transmitter.



Allow the user to navigate within the list by pressing the green button. The right arrow  allows the user to move in ascending order while the left arrow  can be used to move in descending order. The selection change can be done using the navigation button.

Identity code of receiver in position 1 on the list.



Please make sur that the ID Code corresponds to the one of the receiver wanted.



When the “list” is completed, please check that the receivers positions in the list and their respective ID code are correct. Receivers ID codes ID and positions in the list can be seen on “Tables” menu « Tables ». Chapter [§4.8.3.3 Tables](#).

7.9.2.1 “Send” menu

Once the list is created, it must be exported to all concerned receivers using the “Send” menu. To do this, the chosen receiver must be selected using the target discriminator. (See chapter §7.9.1)



 **The list created must necessarily be sent to all the receivers so that they know each other and the life signal works (if it is present in the configuration sheet).**

7.9.2.2 “Receive” menu

The “Load” menu allows to import on a transmitter a list contained on a receiver. To do this, the chosen receiver must be selected using the target discriminator. (See chapter §7.9.1)



 **This menu is used for a transmitter replacement or to retrieve the list contained in a receiver if it has been accidentally deleted from the transmitter.**

7.9.2.3 “Remove” menu

The “Delete” menu allows to delete the list contained in a transmitter.



This menu deletes the list contained in a transmitter without confirmation request. If the list is deleted, a new one must be created following the “Change” procedure described in chapter §7.9.2.1 or by changing the list contained in a receiver using the “Load” option following the procedure described in chapter §7.9.2.3. Use this option only in case of high necessity, otherwise use the delete option (bin pictogram) from the “Change” procedure described in chapter §7.9.2.1.

7.9.3 Exploitation

Now, knowing that the receivers list has been created at the previous step following procedure described in chapter §7.9.2, it only needs to enter in exploitation mode in order to control each receiver separately from a maximum of 32 as shown in the following picture:

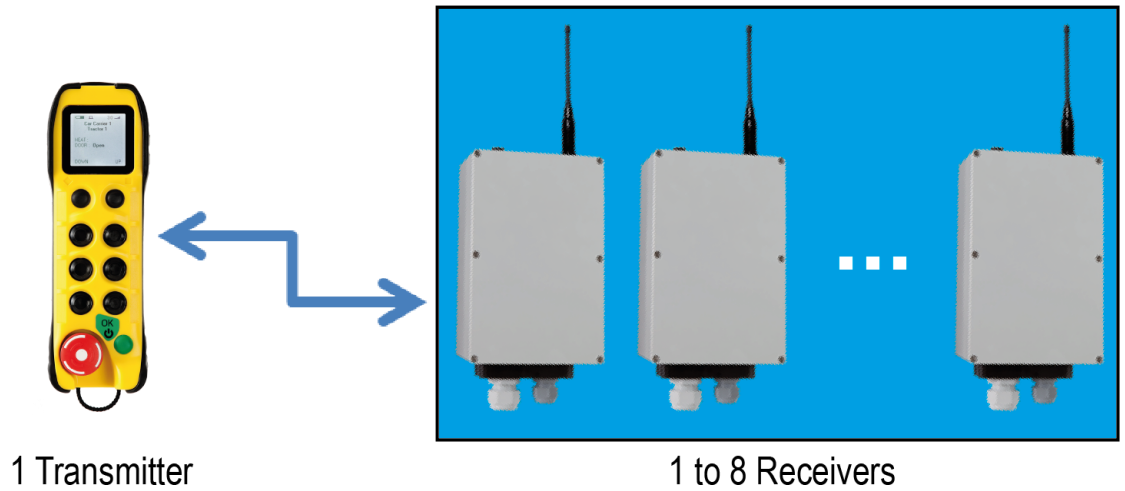

If the previous step regarding the list creation has not been performed, please refer to and perform it because entering in exploitation mode will not be possible without this beforehand configuration.

A configuration example achievable using the “MultiDevices” function is detailed on the next page.

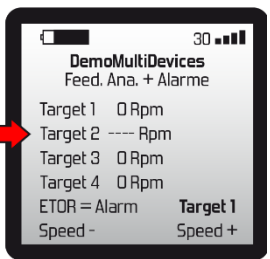
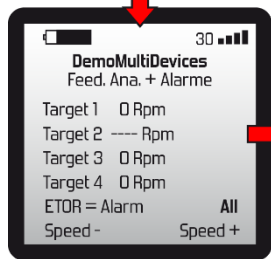

Once the list has been created, the “MultiDevices” function allows to operate one or several receivers present within a list without realizing an association.

“Target” corresponds to the different receivers to control. (“Target” terminology is an example and it is customizable on iDialog sheet)

“1” corresponds to the number of the receiver in the first position of the recorded receivers list.

The “tab” button is used to navigate between the receivers within the drop-down list.

The “increment” button is used to select or unselect the desired receivers.

The green button allows to start once all desired receivers are selected.

Usecase example:

Using the “increment” button defined in iDialog, it is possible to communicate with only one or all the receivers among the ones present in the list and to get analogic feedback from them.

The operation is fully configurable in the iDialog software.

If one or more selected receivers are unavailable (missing or already used by another transmitter), the following message is displayed:



7.9.4 Exploitation stop

Several events can lead to an exploitation stop. These events are listed below.

Transmitter side:

- The operator triggers the emergency stop.

Receiver side:

- The life signal between receivers is exceeded and receivers are set in safe mode.
- When one or more receivers leave the "exploitation" mode for the "safe" mode, they change their radio channel from the operating channel to the rest channel.

7.9.5 Rest channel and operating channel

The rest channel is fixed by the configuration sheet and cannot be changed from the transmitter. It is the channel on which all receivers are in listening mode when they are not in exploitation.

The operating channel (active channel) must be different from the rest channel and can be changed from the transmitter. It is the channel on which the transmitter controls the receivers in operation.

If several transmitters are used at the same time within the park, their associated operating channels must be different.

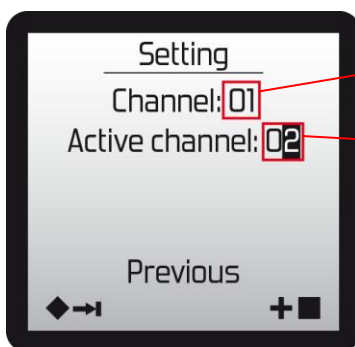

Rest channel: All receivers within the park are in listening mode on this channel until the start of exploitation.

Operating channel: This channel must be different on each transmitter. This is the channel used in exploitation.



If the installation includes several "Parks" of receivers configured in "MultiDevices", the rest channel of each park must be different from the one of the other "Parks". The rest channel can be defined via iDialog.

7.9.6 List transfer from transmitter to transmitter

The lists can easily be transferred from one transmitter to another one using the “Send” and “Load” functions.

To transfer a list from one transmitter to another one, the following steps must be completed:

- Associate the spare transmitter with all receivers following the procedure described in chapter §7.9.1,
- Start the transmitter containing the list we want to transfer,
- Send the list to a receiver using the “Send” function following the procedure described in chapter §7.9.2.2,
- Start the spare transmitter that needs to retrieve the list,
- Retrieve the list contained in the receiver using the “Load” function following the procedure described in chapter §7.9.2.3,
- Finally, both transmitters own the same receivers list.

7.10 "Frequency agility" automatic channel change function

Note: This function can be activated via the **Setup / Radio / Setting / mode**

Depending on the radioelectric noise in the radio channel used, or in case of consecutive passive shutdowns occurring during operation, the Receiver automatically selects another operating radio channel.

This automatic change may be triggered when the Receiver is in the following modes:

- **Safety** (the safety relays are deactivated):

The Transmitter requests start up. If it does not get a response from the Receiver, it searches for it based on a known radio channel table.

When the Receiver responds, its starts (the safety relays are activated) and the new radio channel becomes the current radio channel.

If the Receiver is not found, the Transmitter keeps the last current radio channel.

- **Operation** (when working, the safety relays are activated):

Before the receiver switches to the "safety" mode to change the radio channel, it remains on the current channel for 2 seconds in order to attempt to warn the Transmitter of this change.

If the Transmitter receives the information, it changes radio channel, the "**Safety**" alert message appears on the display screen. The link can thus be restarted by pressing the green "on" pushbutton.

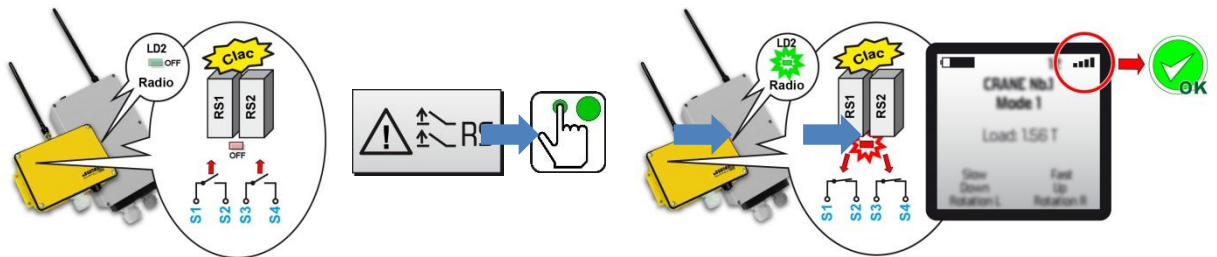

If the Transmitter has not received the radio channel change information and no message has appeared on the screen, you must shut down the Transmitter (press the stop palm switch) and restart (press the green "on" pushbutton) so that it finds the Receiver.

7.11 "Radio power regulation" function

Note: This function can be activated via the **Setup / Radio / Power / mode**

This function enables you to regulate the radio link quality to a suitable level for the system to operate smoothly.

It does not emit more power than necessary to ensure the radio link between the Transmitter and the Receiver.

Therefore, this tool strongly limits radio spectrum pollution, and this emission principle improves the rejections of adjacent radio channels.

7.12 "Deadman" function (detection of operator inactivity)

The "**Deadman**" function is intended to protect isolated operators and/or those who work on dangerous machines.

This tool automatically triggers an alert, and the shutdown of the equipment controlled if the operator stops moving (suspected malaise, fall, unconsciousness, etc.).

The operator's inactivity can be detected in two ways: either "**manually**", or "**automatically**".

7.12.1 Manual detection of operator activity

Manual detection is provided as a basic function on all Transmitter types.

Activity is checked by regular pressing at 2 to 60 second intervals on one or more buttons used by the operator.

If the "Deadman" button is not pressed or held down by the operator for the time period configured, the Receiver safety relays are deactivated, and the Transmitter is switched off.

A **pre-alarm** is triggered before the Transmitter is switched off, signally the request to re-arm the "Deadman" counter. The pre-alarm is indicated by a symbol and may be supplemented by an alert message displayed on the transmitter screen, and in option by activating a vibrator.

7.12.2 Automatic detection of operator inactivity by inclinometer (option)

Activity is checked by an "inclinometer" installed in the Transmitter.
If there is no movement, an alert is triggered.

The inclinometer's detection sensitivity can be configured using the **iDialog** programming software or on the display screen: **Setup / Function / Dead man / auto**, use the navigation buttons to select the desired sensitivity.

7.12.3 Vibrator (option)

This option comes in addition to an alarm and can be activated at the same time as the appearance of the alarm.

Activation of the vibrator can be set up using the **iDialog** programming software.

For the "dead man" function, the vibrator can alert the operator to imminent system shutdown if he does not react.

7.12.4 Configuration

The "Deadman" function can be configured via the menu: **Setup / Function / Deadman**

Note: The Receiver must be having its power on to synchronise data with the Transmitter.



Duration: time in seconds before a shutdown is triggered if no control system has been activated or if the inclinometer has not detected any movement. By default, a pre-alarm is triggered 5 seconds before shutdown is triggered*.

Auto (Threshold): adjustment of the movement detection sensitivity by the inclinometer. 5 levels are available, from not sensitive (-) to very sensitive (+).

* = can be changed with the programming software **iDialog**

7.12.5 Use

After starting the radio control, the activity of the operator is analyzed by the "Dead man" function. In normal use, on the Transmitter screen, a pictogram indicates the activity of the operator.

Chronogram of events:

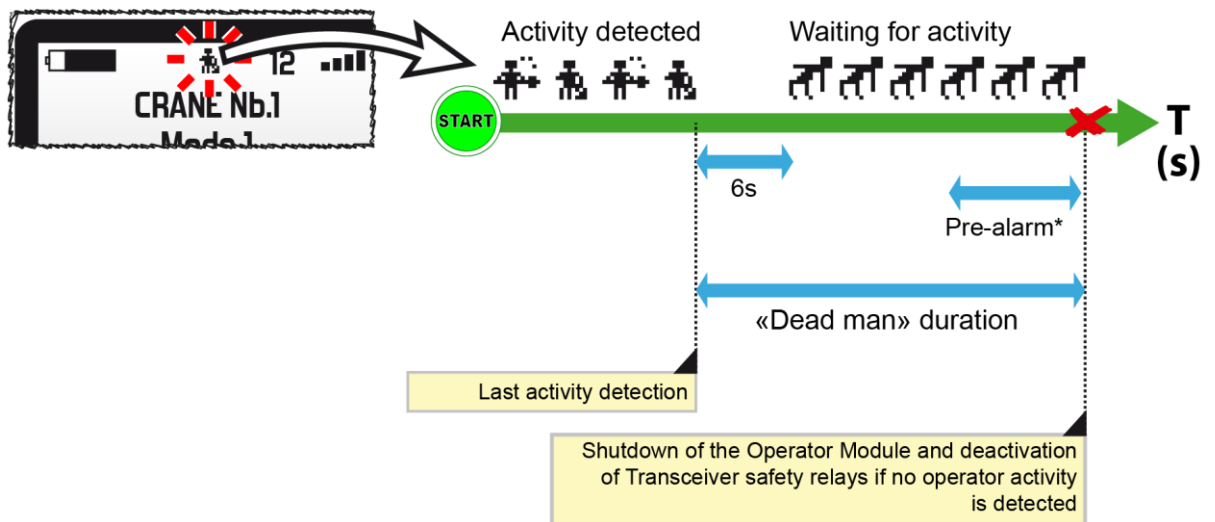

* = Duration can be changed with **iDialog** programming software. During the pre-alarm, an alert message can be displayed on the Transmitter screen and, in addition, a vibrator can be activated to warn the operator of an imminent shutdown of the system if no reset is made.

With **iDialog**, it is possible to parameterize the control elements to be actuated for the "Dead man" periodicity as well as the elements such as inclinometer, vibrator, buzzer etc ...:



(See **iDialog** operating manual: **351910**)

7.13 “Filtering of commands and anti-tapping” option

This system limits tapping commands on the command pushbuttons.

To do so, it is possible to define the minimum rest time for each command pushbutton with the **iDialog** programming software.

7.14 “Multimode 3” and “Multimode 32” options

With a conventional solution, each control component (joystick, selector, button, etc.) controls a function (movement, selection, etc.). It is therefore necessary to have a control component for each function to be piloted.

With the "**Multimode 3**" option it is possible to control up to **3 function sets** with each control unit and up to **32 function sets** with the "**Multimode 32**" option.

Example 1:

- In mode 1, a joystick controls the PWM outputs 1 and 2 to make the cylinder n ° 1 in / out.
- In mode 2, this joystick can control the PWM 3 and 4 outputs to control the cylinder n ° 2.
- In the 3 ... 32 mode

Example 2:

- In mode 1, a joystick controls the two tracks of a drill. (Drilling positioning)
- In mode 2, this same joystick controls the deployment of the drill arm (drill installation)
- In the 3 ... 32 mode

Example 3:

- In mode 1, the buttons are used to control the functions of the front part of a machine.
- In mode 2, these buttons control the functions of the rear part.
- In the 3 ... 32 mode

The screen informs the user about the selected mode and the functions controlled by the control components.

The user selects the desired mode using a **list** or **navigation buttons**.

- **Example 1:** N1 button to call up the list of available modes and select the desired mode.
- **Example 2:** N1 button to switch to the next mode. N2 button to go to previous mode.
- **Example 3:** N1 button to enter next mode and loop back to mode 1.

Each mode has a screen. Each display shows the current mode, the available functions and up to 3 feedback (3 items from the equipment).

Example:

- Mode 1: Oil pressure, fuel level.
- Mode 2: lift load, lifting height
- Mode 3 ... 32

With the **iDialog** software, the installer defines:

- The desired number of modes (within the chosen option);
- The navigation button (s);
- The names of each mode;
- The feedback displayed on each mode;
- The functions controlled by each control unit.

7.15 "Inclinometer" function

Note: All transmitters can be equipped with an inclinometer except for "Gama" models.

This function allows you to continuously monitor the inclination of the Transmitter. If a predetermined inclination threshold (1) has been crossed, actions will be triggered (2) (alert message, shutdown of control actions etc.).

(1) = configurable with the Transmitter or **iDialog** programming software

(2) = configurable with **iDialog** programming software

7.15.1 Configuration

The "inclinometer" function can be set via the menu: **Setup / Function / Inclinometer**

Note: The Receiver must be powered to synchronize the data with the Transmitter.

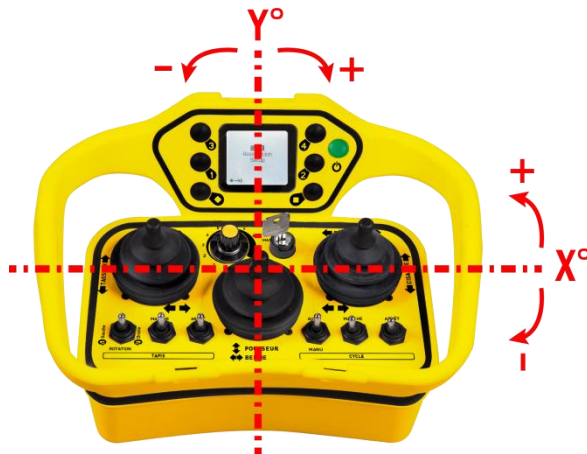
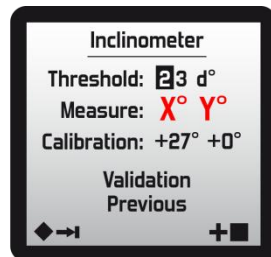

Threshold: The value of the maximum inclination of the transmitter on one of the 2 axes (X or Y), with respect to the indicated inclinations. Adjustable from 3 to 60 °.

Measure: real-time indication of the X and Y inclinations of the transmitter with respect to a horizontal reference system.

Calibration: this function sets the "normal" working position

1. Place the transmitter in its "normal" working position
2. Using the 2 navigation buttons, select "validation" and then confirm with the green pushbutton "on / horn"

Example of "normal" working position (Pika Transmitter):

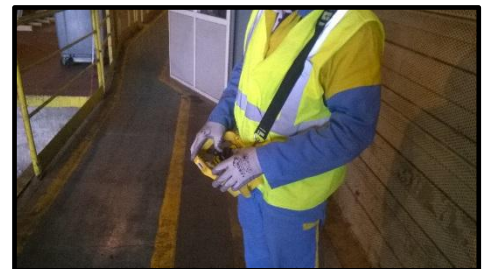

7.15.2 Use

During operation, a **pictogram** on the screen indicates the orientation of the Transmitter:

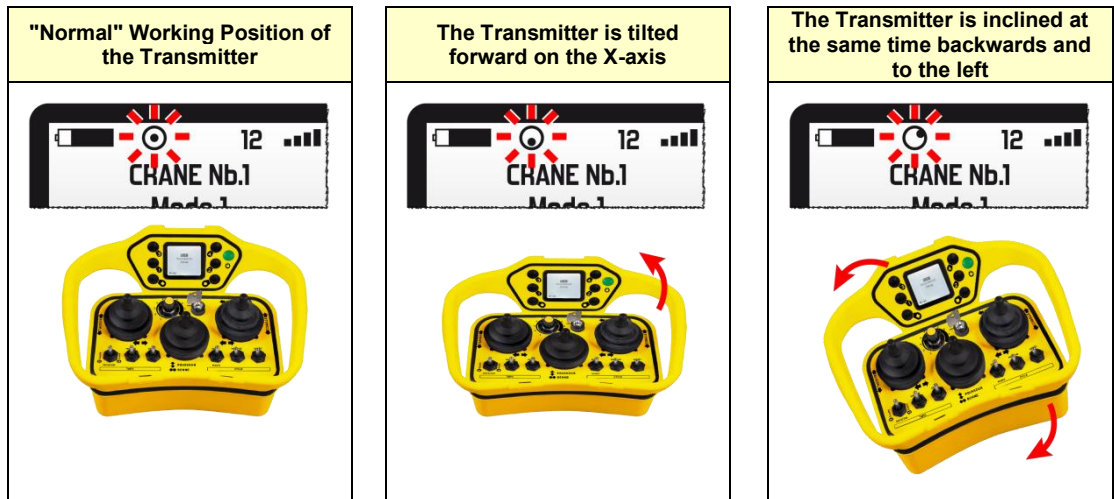

If the value **X + Threshold** or **Y + Threshold** is reached, an alert message appears on the screen, until the position of the slightly less inclined transmitter is returned.

Some control devices (joysticks, selector switches, etc.) can be made inoperative*.

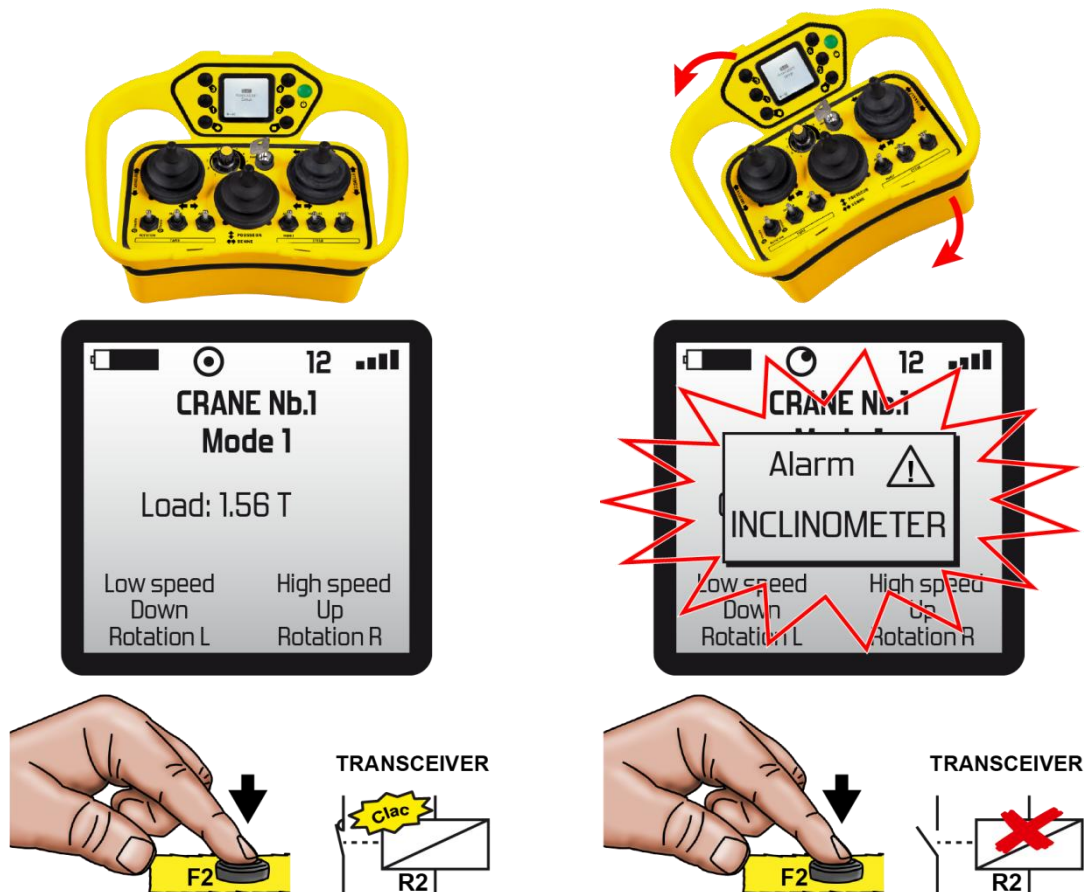

* = Requires special programming by equations, consult our technical support department.

8 Instructions for installation and commissioning

8.1 Instructions for electrical connection of the receiver

IMPORTANT:

IF RECEIVER IS DIRECTLY SUPPLIED FROM THE NETWORK DISTRIBUTION, THE SCHEMA OF THE POWER SUPPLY NETWORK TYPE "IT"- SHALL NOT BE USED TO SUPPLY THE RECEIVER.

- The electrical installation must be realized by professional trained and certified.
- To avoid any risks of electrocution, don't open the Receiver housing when powered. The opening of the housing must be done by ensuring that the power supply cables, and control cables are out of voltage.
- An appropriated disconnection mean must be supplied as an integral part of the building installation.
- The receiver power supply circuit must be directly related to the power supply circuit of the radio-controlled equipment.
- The receiver shall be protected by a means of protection against overcurrent (fuse or circuit breaker), with an appropriate breaking capacity. The qualified installer shall install the equipment by respecting the local regulations in force.
- When the Receiver is supplied with 230 Vac, the power cable shall be separated from the "control" cable. In the case of use of EEC-type electrical plug, the color of the plug shall be "BLUE".

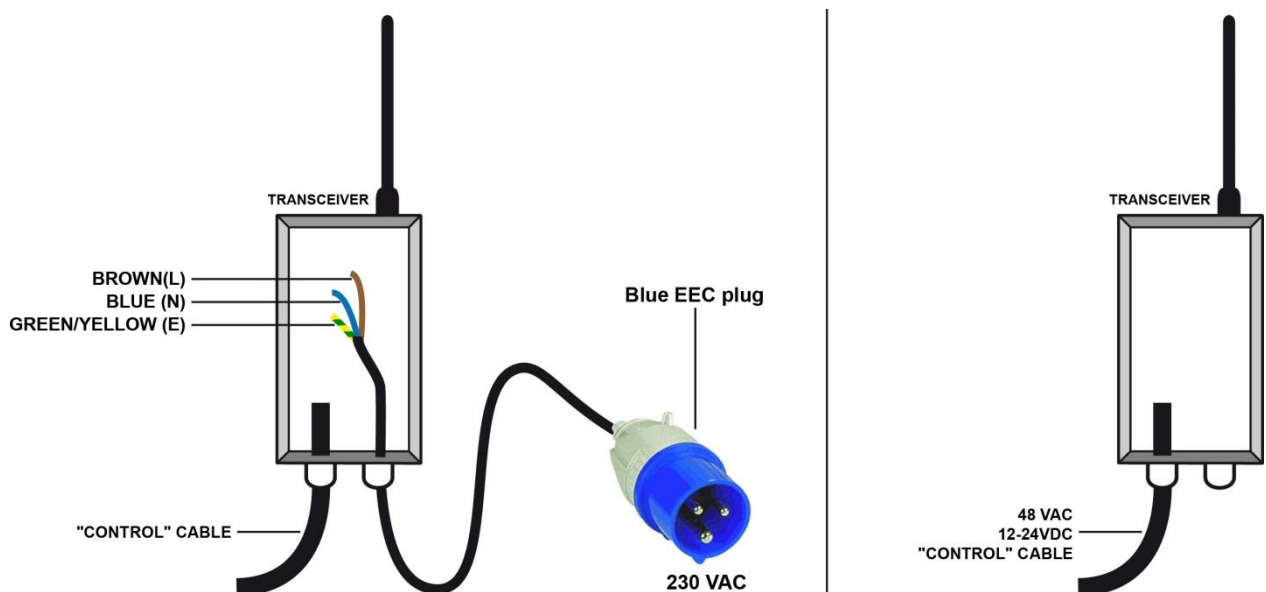

- In cable path, power cables should be separated from the control cables, by observing a minimum spacing (20 cm) between the various classes:
 - **Class 1:** Radio, analogue signals
 - **Class 2:** Mains for supply of various components,
 - **Class 3:** Power control of motors, variable speed drives, etc....If only one cable path is available, the cables of different classes should be separated as much as possible
- To maintain the reinforced insulation inside the Receiver housing, it is mandatory to increase the insulation of cables carrying high voltages with insulating sleeves.

- **Conductor wire sections to be observed for the safety and functional relays connected to the main:**
Be sure to observe the min. /max. wire sections listed below for electrical connection:

Nominal Current A	Minimal size of connectors	
	Section mm ²	AWG or Kcmil [section in mm ²]
3	0.5	20 [0.5]
6	0.75	18 [0.8]
10	1 (0.75)	16 [1.3]

- **The type of wire used for wiring the Safety and functional relay outputs connected to the main, is mandatory:** class 1 size 18AWG with min temperature range -25°C to +60°C. The double insulation or reinforced insulation must be greater than 0.4mm.
 - Warning: If the voltage applied to the safety or functional relays is greater than 30 V rms, 42.4 V peak, or 60 V dc, the installation must comply with the rules for mechanical insulation, fire insulation according to IEC 62368-1. The installer must warrant that no wires can touch the board.
- Be sure not to exceed the minimum and maximum characteristics specified in «Technical characteristics/Receivers» section, by installing, if necessary, an additional load or intermediate relays (auxiliary contacts in electrical control cabinet for power control, for example).
- **Interference suppression of the electrical installation and protection of the power supply:**
In the event of inductive loads on the Receiver relay outputs (contactor coils, solenoid valves or electro-brakes), interference suppression devices such as capacitors, RC circuits, diodes, etc. must be placed directly at the terminals of the controlled components using the shortest possible connections. A pull-up resistor should also be used on the controller inputs.

Examples of protection system to be used:

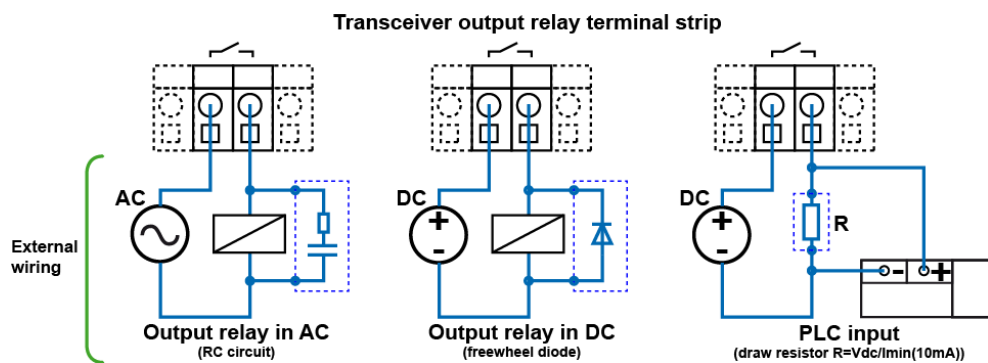

8.1.1 Multi-strand wires: use of wire end ferrules is mandatory

Where flexible multi-strand wires are used, wire end ferrules must be used to avoid false contacts and short-circuits.



8.2 Connecting the power supply



TO AVOID ANY RISK OF ELECTROCUTION, NEVER OPEN THE TRANSCEIVER HOUSING WHICH IS POWERED UP.

The opening of the housing must be done by ensuring that the power supply cables and control cables are out of voltage

If flexible stranded wire is used, crimped terminations must be used to avoid false contacts and short circuits.

To open the connection terminal strips:

- 1) Vertically push the screwdriver (flat tip screwdriver of 1.5 to 3 mm width) on the slot,
- 2) Exercise a moderate pressure up to opening the terminal,
- 3) Insert the wire,
- 4) Remove the screwdriver.

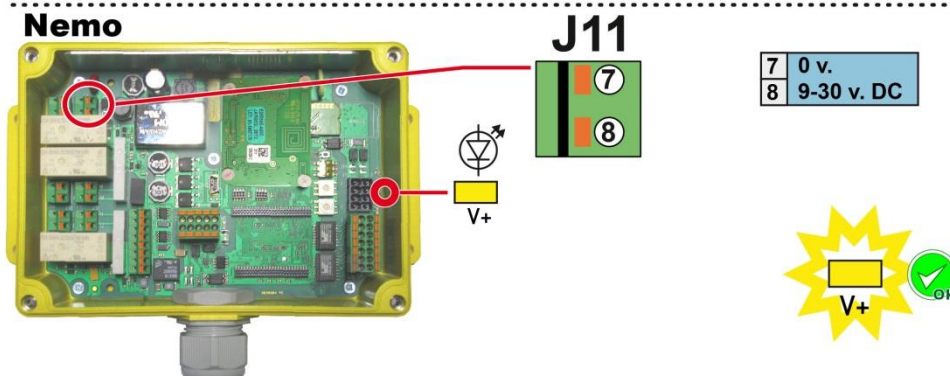
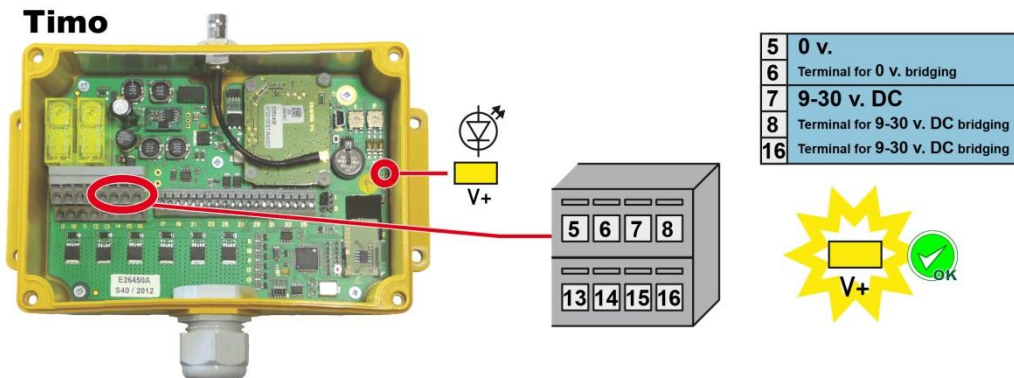
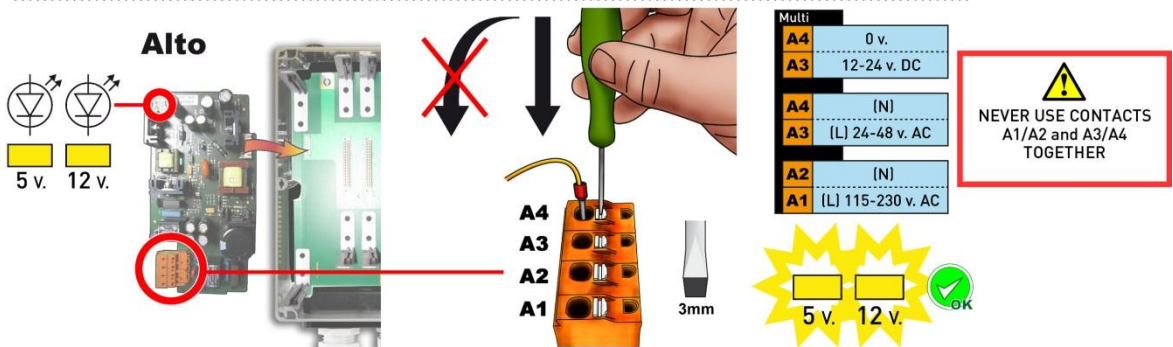
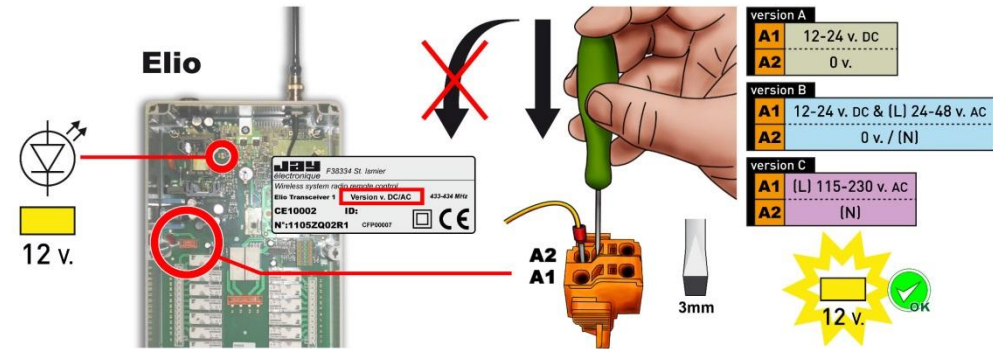

8.3 Installing the Receiver

- Receiver cable entries are done through cable glands M25 and M32. These cable glands are designed to tightness and anchor the cable (compliant with EN 50262). The compliance shall require the use of cables of 16mm to 21mm diameter and the application of torques: for M25 "5 to 7.5 Nm" for M32 "7.5 to 10Nm".
- The Receiver must be installed in a location which is sheltered from impacts and weather, in an area which is easy to access.
- The antenna must be installed at a distance from the class 3 cables and power components (power supply, motor, variable speed drives ...) while remaining in an area which is favourable to radio reception.
- The receiver and the antenna must be located at a height in a manner to be inaccessible to non-skilled people (3 meters above the ground and the operator using the transmitter).
- No metal object which could form a screen should be located between the operator and the antenna (risk of communication cut-out).

8.3.1 Positioning the Receiver

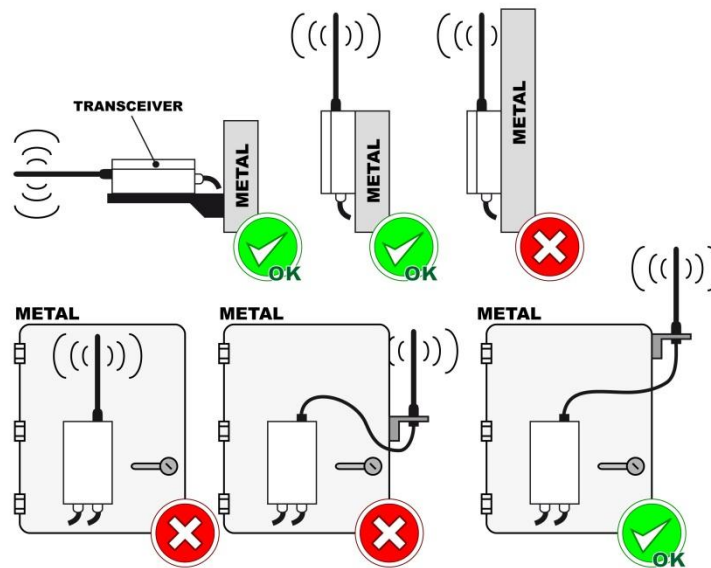

8.3.1.1 Example: Double girder travelling cranes and couples travelling cranes

It is advisable to remote the receiving antennas of the Receivers under the girders, and aim them vertically towards the radio control area, as shown below:

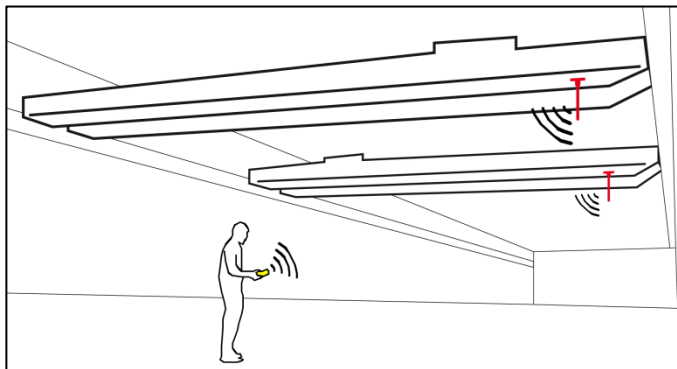

- In case of disturbance or degradation of the radio signal, it is preferable to use $\frac{1}{2}$ wave type antennas, ex: **VUA103AM** (with magnetic base and 3m of cable).
- The radio emission power can also be changed, **respecting the maximum level of use of the regulations in force**.

8.3.2 Antennas

8.3.2.1 418-419MHz and 433-434MHz Bands

<p>Antenna reference: VUA001A Type: straight, 1/4 wave, BNC connection Approximate length: 190mm</p>	 <p>Antenna supplied as standard with the Receiver</p>
<p>Antenna reference: VUA002A Type: straight, 1/2 wave, BNC connection Approximate length: 335mm</p>	
<p>Antennas references:</p> <ul style="list-style-type: none"> • VUA100AH (with 0,5m cable) • VUA102AH (with 2m cable) • VUA105AH (with 5m cable) • VUA110AH (with 10m cable) <p>Type: through insulated remote, 1/2 wave, BNC connection Approximate length: 320mm Required drill hole: 15mm</p>	
<p>Antennas references:</p> <ul style="list-style-type: none"> • VUA103AM (with 3m cable) • VUA105AM (with 5m cable) <p>Type: insulated magnetic remote, tuned, BNC connection Approximate length: 440mm</p>	
<p>Antennas references:</p> <ul style="list-style-type: none"> • VUA103AV (with 3m cable) • VUA105AV (with 5m cable) <p>Type: through uninsulated remote, 1/4 wave, BNC connection Approximate length: 180mm Required drill hole: 12mm or 19mm (ring 2 diameters supplied)</p>	

8.3.2.2 869MHz band

<p>Antenna reference: VUA001B Frequency Range: 860-920 MHz Antenna gain: 1.5 dBi (need grounded 16x16cm) Type: straight, 1/4 wave, BNC connection Approximate length: 90mm</p>	 <p>Antenna supplied as standard with the Receiver</p>
<p>Antenna reference: VUA002B Frequency Range: 890-960 MHz Antenna gain: 5 dB (compared to 1/4 wave) Type: straight, 1/2 wave, BNC connection Approximate length: 200mm</p>	
<p>Antennas references: • VUA100BH (with 0,5m cable) • VUA102BH (with 2m cable) • VUA105BH (with 5m cable) • VUA110BH (with 10m cable) Frequency Range: 860-960 MHz Antenna gain: 4 dBi Type: through insulated remote, 1/2 wave, BNC connection Approximate length: 190mm Required drill hole: 15mm</p>	
<p>Antennas references: • VUA103BM (with 3m cable) • VUA105BM (with 5m cable) Frequency Range: 820-960 MHz Antenna gain: 5 dBi (need grounded 60x60cm) Type: insulated magnetic remote, tuned, BNC connection Approximate length: 320mm</p>	
<p>Antennas references: • VUA103BV (with 3m cable) • VUA105BV (with 5m cable) Frequency Range: 900-920 MHz Antenna gain: 2 dBi Type: through uninsulated remote, 1/4 wave, BNC connection Approximate length: 100mm Required drill hole: 12mm or 19mm (ring 2 diameters supplied)</p>	

8.3.2.3 911-918MHz band: authorized antennas according to FCC Part 15.204

<p>Antenna reference: VUA001B Frequency Range: 860-920 MHz Antenna gain: 1.5 dBi (need grounded 16x16cm) Type: straight, 1/4 wave, BNC connection Approximate length: 90mm</p>	 <p>Antenna supplied as standard with the Receiver</p>
<p>Antenna reference: VUA002B Frequency Range: 890-960 MHz Antenna gain: 5 dB (compared to 1/4 wave) Type: straight, 1/2 wave, BNC connection Approximate length: 200mm</p>	
<p>Antennas references: • VUA100BH (with 0,5m cable) • VUA102BH (with 2m cable) • VUA105BH (with 5m cable) • VUA110BH (with 10m cable) Frequency Range: 860-960 MHz Antenna gain: 4 dBi Type: through insulated remote, 1/2 wave, BNC connection Approximate length: 190mm Required drill hole: 15mm</p>	
<p>Antennas references: • VUA103BM (with 3m cable) • VUA105BM (with 5m cable) Frequency Range: 820-960 MHz Antenna gain: 5 dBi (need grounded 60x60cm) Type: insulated magnetic remote, tuned, BNC connection Approximate length: 320mm</p>	
<p>Antennas references: • VUA103BV (with 3m cable) • VUA105BV (with 5m cable) Frequency Range: 900-920 MHz Antenna gain: 2 dBi Type: through uninsulated remote, 1/4 wave, BNC connection Approximate length: 100mm Required drill hole: 12mm or 19mm (ring 2 diameters supplied)</p>	

8.3.2.4 2.4GHz band: authorized external antennas according to FCC Part 15.204

<p>Antenna reference: VUC001C Radio frequency range: 2.4 GHz Antenna gain: 2.15 dBi Characteristic: SMA - Adjustable from 0 to 90°C Approximate length: 136x12.5 mm</p>	
<p>Antenna reference: VUC105CC Radio frequency range: 2.4 GHz Antenna gain: 3 dBi Characteristics: SMA - Can be fixed to walls and posts / IP65 / UV resistance Approximate length: 180x60 mm Cable length: 5m</p>	
<p>Antenna reference: VUC103CH Radio frequency range: 2.4 GHz Antenna gain: 3 dBi Characteristic: SMA - IP65 Approximate length: 48x50 mm Cable length: 3m</p>	
<p>Antenna reference: VUC103CM Radio frequency range: 2.4 GHz Antenna gain: 2 dBi Characteristic: SMA - Can be fixed on any metal surface thanks to its magnetic base Approximate length: 121x7.3 mm Cable length: 3m</p>	

8.3.3 Mounting the Receiver:

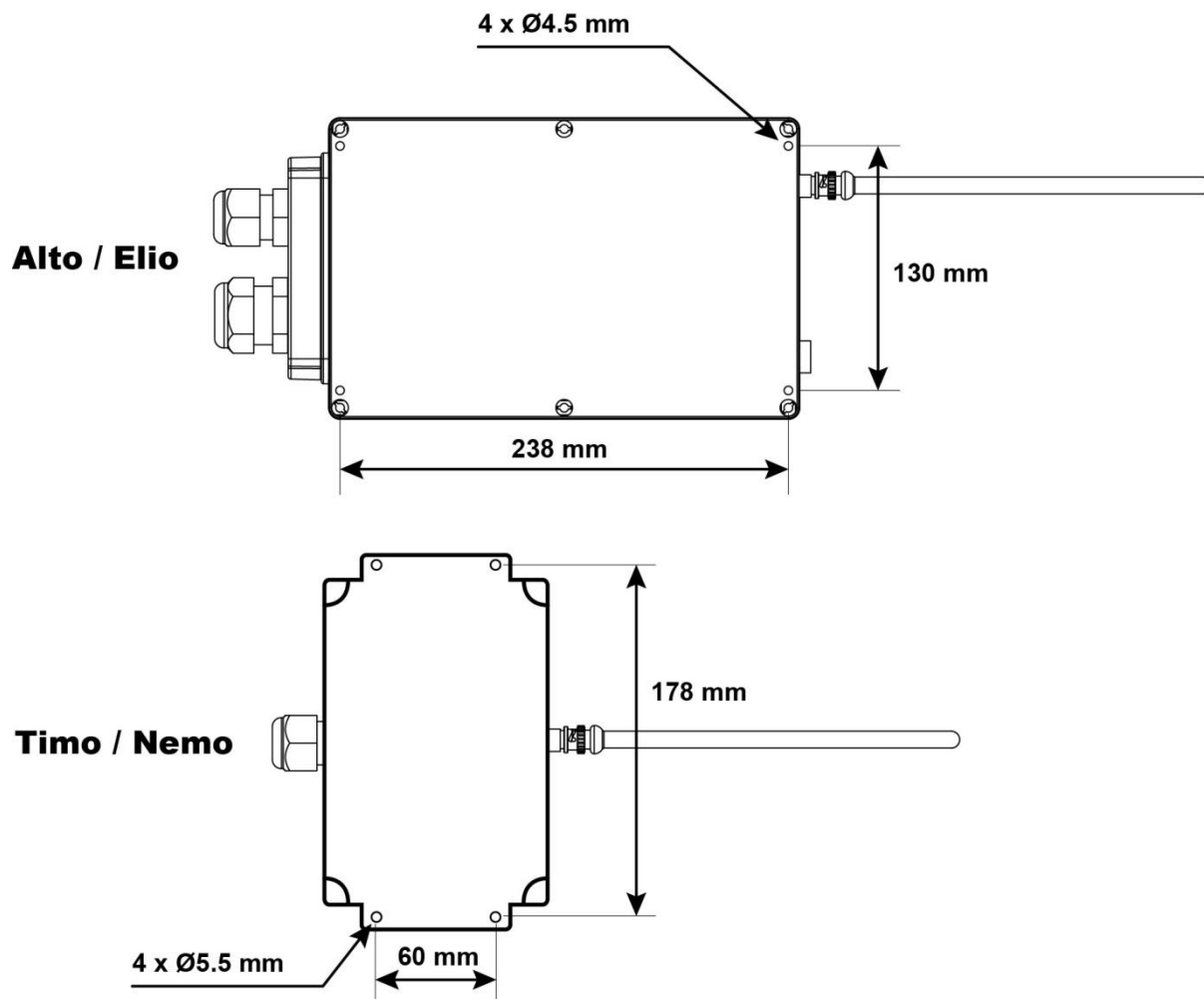

- The installer must fit the equipment to be radio-controlled with appropriate references with respect to the transmitter control components and the movements or functions of the equipment.

8.4 Wiring diagram: use of safety relays RS1 and RS2

The safety relays RS1 and RS2 are used to interrupt the common control line of the radio-controlled equipment:

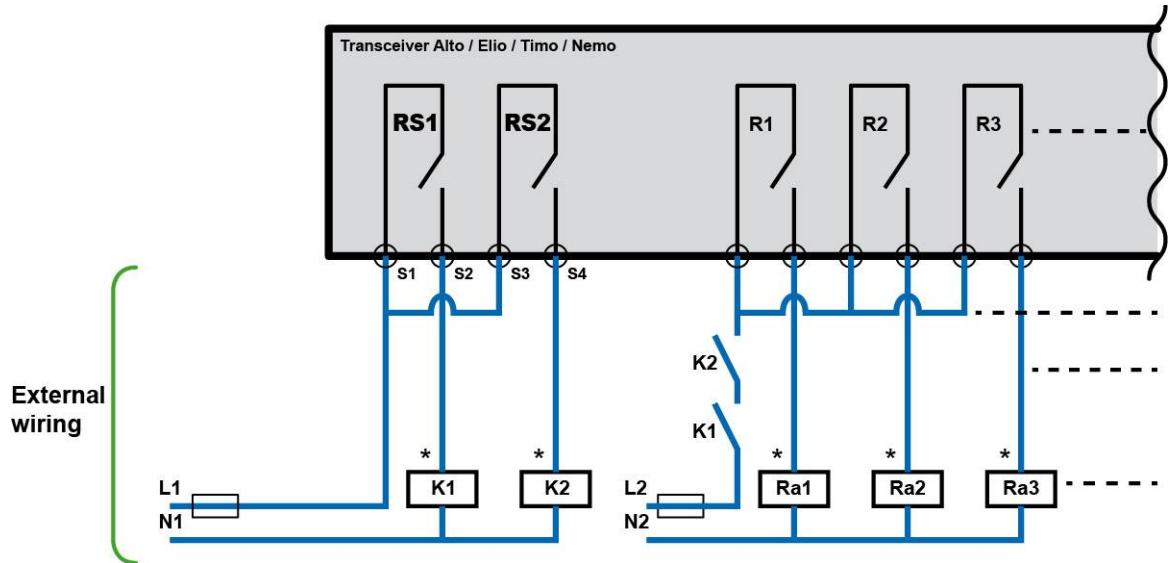

K1 and **K2** are guided contact contactors, to be integrated in the safety circuit of the system controlled.

The 2 safety relays **RS1** and **RS2** are activated when radio communication is set up between the transmitters and the Receiver, and are automatically maintained up to the moment of active or passive shutdown (action on palm switch, loss of radio link, battery discharged, "Standby" time elapsed ...)

* = The use of overvoltage limiting circuits will increase the service life of the relay contacts (ex: RC circuits with AC, diodes + Zener with DC, etc.)

8.5 Instructions for commissioning

- Before commissioning, the installer must check the passive stop time setting. The value of the passive stop time is available in the menu "configuration => function => Passive stop". The stop characteristics are described in chapter §16.3.
- Before commissioning, the installer must perform a final check to make sure of the match-up between the control components of the transmitter and the relays (or solid-state outputs) of the desired Receiver.
- During the previous check, the installer must check that when the green "On/Horn" button is pressed on startup, only the safety relays are in the "ON" state.
- **Verify the priority general shutdown mode** (remote control in operation and radio link established):

Active stop: When the stop palm switch button on the transmitter is pressed, the Receiver safety relays (RS1 and RS2) should instantaneously change state.

Passive stop: When the battery is removed from the transmitter in operation, the Receiver safety relays (RS1 and RS2) should change state within the passive stop time. The passive stop time can be configured by iDialog.

- **If an electrostatic discharge occurs on antenna plug, communication could be lost, OFF and ON of power supply is necessary for restart normally the product.** Be sure that all ESD (electrical charges) you can wear are grounded before connecting antenna. Always touch a metallic grounded structure prior to touching antenna connector.

9 Maintenance

The spare parts are only accessible to persons having been appropriately trained by JAY Electronique at its training centre.

9.1 Replacement of a transmitter or of a Receiver

9.1.1 Transmitters

In the event of a transmitter failure, a backup transmitter can be used. To do so, perform the procedure detailed in the "**Association**" menu.

Validate the selected Receiver; the configuration of the previous transmitter used is recovered and your replacement transmitter is ready to operate.

9.1.2 Receiver

The Receiver is equipped with a **SIM** card which can be disconnected from the management board. The SIM card contains all the configuration parameters. In the event of a failure, the card can be removed and placed in a replacement Receiver having the same configuration (additional boards for Alto and daughter board for **Elio**).



TO AVOID ANY RISK OF ELECTROCUTION, NEVER OPEN THE TRANSCEIVER HOUSING WHICH IS POWERED UP.

The opening of the housing must be done by ensuring that the power supply cables and control cables are out of voltage

9.2 USB connector

The Transmitter and the Receiver are equipped with a mini-B USB interface. Using the **iDialog** software, this interface will allow you to display and modify the system configuration parameters. To access this connector, you must open the Receiver unit.



TO AVOID ANY RISK OF ELECTROCUTION, NEVER OPEN THE TRANSCEIVER HOUSING WHICH IS POWERED UP.

The opening of the housing must be done by ensuring that the power supply cables and control cables are out of voltage

9.3 Chargers

9.3.1 Indicator light on support chargers does not come on

Power supply problem (check the voltage adapter and the connection to the support charger).

9.3.2 Transmitter does not charge on its support charger

Check that the contacts on the support charger are clean.

10 Inspection and servicing

BEFORE PERFORMING ANY SERVICING OPERATION, SWITCH OFF THE MAIN POWER SUPPLY OF THE CONTROL SYSTEM (charger included)

10.1 Inspection and servicing of transmitter

The transmitter housing must not be opened.

If one of the membranes of the function buttons or the seal of the transmitter is damaged, the product must not be used anymore until the replacement of these tightness spare parts.

In the opposite case, any liquid, any dust or any foreign body can damage the transmitter.

The attention of the user is attracted to the risks of the use of the remote control in an environment containing solvents of polymers or glues which can degrade the good functioning of transmitter mechanical organs.

Verify regularly the good state of the transmitter, paying special attention to the function button membranes, to the electronic key connector and to the battery.

Clean the transmitter by eliminating any foreign body.

Only use nonaggressive cleaning product on base of soapy solution.

Once a year, it is necessary to check the function of Emergency stop and safety relays and the safety function relay if the product has it.

10.2 Inspection and servicing of charger

The attention of the user is attracted to the risks of the use of the remote control in an environment containing solvents of polymers or glues which can degrade the good functioning of support chargers mechanical organs.

Clean the charger by eliminating any foreign body.

Only use nonaggressive cleaning product on base of soapy solution.

Check that the battery compartment remains clean and dry.

10.3 Inspection and servicing of Receiver

The Receiver can be dismantled only by a trained staff, in a "controlled" environment, spare parts can be changed only by identical and original parts.

Check the antenna connection and check that it is clean and free of any oxidation.

Check the wiring of Transmitter to electrical unit on power supply and machine, and wiring of function outputs.

Check the correct operation of stop circuits, active and passive.





Check the condition of cover seal, tightening of screws and cable glands.

Clean the Receiver by eliminating any foreign body.

Only use nonaggressive cleaning product on base of soapy solution.

11 Technical characteristics

11.1 Transmitters

	BETA	GAMA	PIKA	MOKA
				
Housing Material	ABS	ABS	Skock-proof polyamide	Skock-proof polyamide
Tightness	IP65	IP65	IP65	IP65
Weight	2 bts: 400 g 6 bts: 485 g	6 bts: 768 g 10 bts: 893g	1 Joystick: 1300 g 2 Joysticks: 1400 g	1800g max
Dimensions	2 bts: 182 x 75 x 50 mm 6 bts: 235 x 75 x 50 mm	6 bts: 290 x 93 x 64 mm 10 bts: 360 x 93 x 64 mm	243 x 180 x 170 mm	297 x 215 x 170 mm
Operating temperature range	-20°C to 50°C			
Storage temperature range of housing alone	-20°C to +70°C			
Storage temperature range of battery	-20°C to +70°C			
Power supply	Li-ion battery			
Endurance (25°C) of radio link, activated	10 hours			
Charging time (endurance > 80%)	3 Hours (20 mn of charge get 1h autonomy)			
Charging temperature range	0°C to 40°C (charger Tma = 40°C)			
Display	Baklit LCD display, 128 x 128 pixels, Black/White			
USB interface (2)	Mini USB type B connector only for configuration and diagnostics with IDialog software			
Emergency stop	2 positions with rotary unlock system			

Frequency range	Characteristics relating to the frequency range (available for each MO)				
	419MHz (3)	433 - 434.7MHz	869 MHz	911MHz	2.4 - 2.48GHz
Number of channels /modulation	11/FSK	64/FSK	12/FSK	64/FSK	64/DSSS
Power Level step	15	15	5	5	10
Power (regulation)	< 10mW	< 10mW	< 5mW	< 1mW	< 10mW
Range in industrial spave (Maximum levels) (1)	50m - 200m	50m - 200m	40m - 150m	25 - 100m	80m - 300m
Range in open space (maximum levels) (1)	400m - 1km	400m - 1km	300m - 800m	200m - 500m	800m -2km
Antenna	Internal antenna	Internal antenna (Optional external antenna on BNC connector)	Internal antenna (Optional external antenna on BNC connector)	Internal antenna	Internal antenna

(1) = Range will vary according to environment conditions of transmitter and reception antenna (metal frameworks, walls ...).
The range is halved every 2 power levels.





The range is also halved if the MT is equipped with the PYA.





The announced ranges are with "remote antenna".

(2) = Diagnosis and programming is carried out using the **iDialog** software (optional).

(3) = Excluding Gama and Pika

11.2 Receivers

	ELIO	ALTO	TIMO	NEMO
				
Housing Material	ABS	ABS	Polyamide fiberglass	Polyamide fiberglass
Tightness	IP65	IP65	IP65	IP65
Weight	2kg (approx.)	2kg (approx.)	585g (approx.)	600g (approx.)
Dimensions (not including antenna)	160 x 250 x 90 mm	160 x 250 x 120 mm	190 x 120 x 60 mm	190 x 120 x 60 mm
Cable lead-out	By 2 cable glands (size M32/M25) or by plug-in connector, 32, 40 or 72 contacts		- 1 or more cable glands - Plug-in industrial connector 10 or 16 points - Circular connector M12 or C16	- cable gland M25 - circular connector M12 (Bus option) - 1 cable gland M16 (IR option)
Power supply	- 12-24Vdc/48Vac (±15%) -115-230Vac (±15%)	115-230Vac (±15%) 24-48Vac (±15%) 12-24Vdc (±15%)	MELV/PELV: 9 to 30Vdc Max power < 15W	MELV/PELV: 9 to 30Vdc Max power < 18W
	Internal protection of the power supply: Against polarity inversions for DC versions Against overcurrents by fuse: T3.15A (DC), T500mA (AC)			
Maximum consumption	15W	24W	4W	18W
Response time	In startup: 0.5s max On command: 300ms max	See characteristics of additional boards	In startup: 0.5s max On command: 300ms max	In startup: 0.5s max On command: 300ms max
Stop times	Active: between 174 to 894 ms (The extreme value of 894ms corresponding when only the tenth radio frame from operator module is received correctly) Passive: adjustable from 0.3 to 2s (IDialog software)			
USB interface (2)	Mini USB type B connector only for configuration and diagnostics with IDialog software			
Safety relays characteristics	2 relays: RS1 and RS2 Relays with linked contacts • Contacts: AgNi10+Au5µm • Maximum power at cosphi=1:2000VA • Maximum permissible current (at 20°C): 6A • Maximum permissible current (at max operating temp 50°C): 5A • Maximum voltage switching: 250Vac • Minimum current / voltage advised switching: 50mA / 12Vdc • Electrical life: 100 000 switching cycles at 250Vac, 6A, cosphi=1 • Test per EN 60947-5-1: DC13 at 2A / 24Vdc – AC15 at 1A / 230Vac	2 relays: RS1 and RS2 Relays with linked contacts • Contacts: AgNi10+Au5µm • Max. permissible current (at 20°C): 8 A • Maximum permissible current (at max operating temp 50°C): 5 A • Max. voltage switching: 30 Vdc • Min. current / voltage advised switching: 50 mA / 12 Vdc • Tests per EN 60947-5-1: DC13 at 2 A / 24 Vdc	3 relays: RS1, RS2 and RSF3 Relays with linked contacts • Contacts: AgNi10+Au5µm • Maximum power at cosphi=1: 2000 VA • Maximum permissible current (at 20°C): 8 A • Maximum permissible current (at max operating temp 50°C): 5 A • Maximum voltage switching: 250 Vac • Minimum current / voltage advised switching: 50 mA / 12 VDC • Electrical life: 100 000 switching cycles at 250 Vac, 6A, cosphi=1 • Tests per EN 60947-5-1: DC13 at 2 A / 24 Vdc - AC15 at 1A / 230Vac	
	The safety relays must be protected against over current by adding a fuse 5A / 250Vac / T. The fuse is not provided by JAY electronique.			

	ELIO	ALTO	TIMO	NEMO
				
Function relays characteristics	2 connection points, potential free, by contact Spring-type plug-in connectors Function relays: 1 «ON» relay + 12 function relays Independent NO relays <ul style="list-style-type: none"> • Category DC13 0,5A / 24Vdc, AC15 2A / 230Vac • Interrupting capacity max. 2000VA • Max. current 5A • Min. current 10 mA (12 Vmin.) • 100 000 switching cycles at 250Vac, 5A, cos ϕ = 1 • Max. voltage 250VAC 	See characteristics of additional boards	No relay output See characteristics of Inputs/Outputs and features on next page	2 function relays R1 and R2 2 connection points, potential free, by contact AgNi 0.15 gold plate 100 000 switching cycles at 230VAC, 6A, cos ϕ = 1
	The safety relays must be protected against over current by adding a fuse 5A / 250Vac / T. The fuse is not provided by JAY électronique.			
Operating temperature range	-20°C to 50°C	-20°C to +50°C	-20°C to +50°C	-20°C to 50°C
Storage temperature	-30°C to +70°C	-30°C to +70°C	-30°C to +70°C	-30°C to +70°C

	Characteristics relating to the frequency range (available for each MT)				
Frequency range	419MHz (3)	433 - 434.7MHz	869 MHz	911MHz	2.4 - 2.48GHz
Number of channels /modulation	11/FSK	64/FSK	12/FSK	64/FSK	64/DSSS
Power Level step	15	15	5	5	10
Power (regulation)	< 10mW	< 10mW	< 5mW	< 1mW	< 10mW
Range in industrial space (Maximum levels) (1)	50m - 200m	50m - 200m	40m - 150m	25 - 100m	80m - 300m
Range in open space (maximum levels) (1)	400m - 1km	400m - 1km	300m - 800m	200m - 500m	800m - 2km
Antenna	External antenna, BNC connector, type, 1/4 Wave		External antenna, BNC connector, type, 1/2 Wave		External antenna, both SMA connector, type, 1/2 Wave

- (1) = Range will vary according to environment conditions of transmitter and reception antenna (metal frameworks, walls ...).
 The range is halved every 2 power levels.
 The range is also halved if the MT is equipped with the PYA.
 The announced ranges are with "remote antenna".
- (2) = Diagnosis and programming is carried out using the **iDialog** software (optional).
- (3) = Excluding Timo and Nemo

Note : Be careful when ALTO-ELIO products are used with an input voltage of 12Vdc, the power supply requires a strong starting current (10A/5 μ s).

11.2.1 Receiver Alto: Control board characteristics

ELECTRICAL CHARACTERISTICS OF CONTROL BOARD		
Safety relay		
Contact type		3 relays with linked contacts
Contacts and connection		2 connection points per outputs Spring-type plug-in connection
Indication		
Radio status and quality		1 Green indicator light:
Power on		1 yellow indicator light:
fault and diagnostic		1 red indicator light:
1 Logic input		
Contacts and connection		2 connection points, 1 contact spring-type plug-in connectors
Input current		< 10mA
Voltage		0-30Vdc
Low level on input		<2Vdc
High level on input		> 3Vdc
1 Analog input		
Contacts and connection		2 connection points, 1 contact spring-type plug-in connectors
Max. input level		10Vdc or 4-20mA
1 active input consumption		<12mA
1 RS485 serial link		
Contacts and connection		2 connection points, 1 contact spring-type plug-in connectors
Protocol		ModBus RTU slave
Data rate		1200, 2400, 4800, 9600, 19200, 38400, 57600, 115200 bit/s
Parity		None / even (default) / odd
Slave addressing		1 to 247
Outputs independent relay		
		1
Contacts and connection		2 connection points spring-type plug-in connection
Category		DC13 0.5A / 24 VDC, AC15 2A / 230VAC
Interrupting capacity		2000VA max.
Max. current		5A (control relay)
Min. current		10 mA (12VDC min)
Max. voltage		250 VAC
Startup by IR validation (on control board – option)		
Action area limitation by infrared (on control board – option)		
Selection and association between operator modules and transceiver by infrared (on control board – option)		

11.2.2 Receiver Alto: Additional board characteristics

ELECTRICAL CHARACTERISTICS OF BOARD WITH 12 CONTROL RELAY OUTPUTS

Contacts and connection	2 connection points per output spring-type plug-in connection
Outputs	Independent relays - Category DC13 0.5A / 24 VDC, AC15 2A / 230VAC - Interrupting capacity, 2000VA max. - Max. current 5A - Min. current 10 mA (12VDC min) - Max. voltage 250 VAC
	The functional relay must be protected against over current by adding a fuse 5A / 250 VAC/T. The fuse is not provided by JAY electronique
Response time	- On startup: 0.5s max. - On command: 200ms typical

ELECTRICAL CHARACTERISTICS OF BOARD WITH 6 ANALOG OUTPUTS + 1 bypass OUTPUT

Analog Outputs	
Contacts and connection	2 connection points per output spring-type plug-in connection
Outputs level	0 / 10 VDC - 10 / 0 / 10 VDC 3 / 6 / 9 VDC 6 / 12 / 18 VDC
Voltage output max. current	10 mA
Bypass output	
Contacts and connection	2 connection points per output spring-type plug-in connection
Max. interrupting capacity	4A max
Max. voltage	30VDC

ELECTRICAL CHARACTERISTICS OF BOARD WITH 12 LOGIC INPUTS + 2 ANALOG INPUTS

Outputs 12 VDC	50 mA max
Logic Inputs	
Contacts and connection	1 connection points per input, 4 common contacts spring-type plug-in connection
Consumption of an active input	<10 mA
Voltage	0 to 30 VDC
Low level on input	< 2VDC
High level on input	> 3VDC
Analog inputs	
Contacts and connection	2 connection points Spring-type plug-in connection
Max. input level	10 VDC or 4-20mA

11.2.3 Receiver ELIO: CONTROL Board

ELECTRICAL CHARACTERISTICS OF CONTROL BOARD		
Safety relay	Contact type	2 relays with linked contacts
	Contacts and connection	2 connection points per outputs Spring-type plug-in connection
	Indication	
	Radio status and quality	1 Green indicator light:
	Power on	1 yellow indicator light:
	fault and diagnostic	1 red indicator light:
Function Relay		12
	Contacts and connection	2 connection points per output spring-type plug-in connection
	Outputs	Independent relays
		- Category DC13 0.5A / 24 VDC, AC15 2A / 230VAC
		- Interrupting capacity, 2000VA max.
		- Max. current 5A
		- Min. current 10 mA (12VDC min)
		- Max. voltage 250 VAC
		The functional relay must be protected against over current by adding a fuse 5A / 250 VAC/T. The fuse is not provided by JAY électronique
	Response time	- On startup: 0.5s max. - On command: 200ms typical

11.2.4 Receiver ELIO: Extension board features (option)

ELECTRICAL CHARACTERISTICS OF BOARD		
Logic inputs		2
	Contacts and connection	4 connection points spring-type plug-in connection
	High level on input	> 3VDC
	Low level on input	< 2VDC
	Voltage	0 – 30 VDC max
	Active input consumption	< 20mA
	Galvanic insulation	> 2.5kV
	Analog outputs	
Contacts and connection	2 connection point per output spring-type plug-in connection	
Voltage	0 – 10VDC or 4-20mA	
Max. output current	< 10mA	
Analog input		1
	Contacts and connection	2 connection point spring-type plug-in connection
	Voltage	0 – 10VDC or 4-20mA
	Active voltage input consumption	< 10mA
Modbus RTU Slave		1 RS 485 serial link
	Contacts and connection	2 connection outputs spring-type plug-in connection
	Protection (D+/D-)	ESD/EMI
	Data rate	1200, 2400, 4800, 9600, 19200, 38400, 57600, 115200 bit/s
	Parity	None / even (default) / odd
	Slave addressing	1 to 247

11.2.5 Receiver Timo: Inputs/Outputs and features

ELECTRICAL CHARACTERISTICS OF BOARD

Safety relay		
	Contact type	2 relays with linked contacts
	Contacts and connection	2 connection points per outputs Spring-type plug-in connection
Indication		
	Radio status and quality	1 Green indicator light:
	Power on	1 yellow indicator light:
	fault and diagnostic	1 red indicator light:
Transistor outputs		
	Contacts and connection	1 connection point per output, 1 power supply common contact spring-type plug-in connection
Outputs		
	Max. interuting capacity	4A / output
	Max. admissible current for all outputs	12A
	Max. voltage	30VDC
	Max. power	1/4 W
	PWM frequency	1 to 1000Hz, duty cycle of 1 to 90%, 2 possible frequencies
Logic inputs		
	Contacts and connection	2 connection points spring-type plug-in connection
	High level on input	> 4.5VDC
	Low level on input	< 1.5VDC
	Voltage	0 – 30 VDC max
	Active input consumption	< 20mA
Analog outputs		
	Contacts and connection	2 connection point per output spring-type plug-in connection
	Voltage	0 – 10VDC
	Max. output current	< 10mA
Analog input		
	Contacts and connection	2 connection point spring-type plug-in connection
	Voltage	0 – 30VDC
	Active voltage input consumption	< 10mA
Modbus RTU Slave		
	Contacts and connection	1 RS 485 serial link 2 connection outputs spring-type plug-in connection
	Protection (D+/D-)	ESD/EMI
	Data rate	1200, 2400, 4800, 9600, 19200, 38400, 57600, 115200 bit/s
	Parity	None / even (default) / odd
	Slave addressing	1 to 247

11.2.6 Receiver Nemo: Inputs/Outputs and features

ELECTRICAL CHARACTERISTICS OF BOARD		
Safety relay	Contact type	3 relays with linked contacts
	Contacts and connection	2 connection points per outputs Spring-type plug-in connection
Indication	Radio status and quality	1 Green indicator light:
	Power on	1 yellow indicator light:
	fault and diagnostic	1 red indicator light:
Logical input	Contacts and connection	2 connection points spring-type plug-in connection
	Consumption of an active input	<20 mA
	Voltage	0 to 30 VDC max.
	Low level on input	< 2VDC
	High level on input	> 3VDC
Modbus RTU Slave	Contacts and connection	1 RS 485 serial link 2 connection outputs spring-type plug-in connection
	Protection (D+/D-)	ESD/EMI
	Data rate	1200, 2400, 4800, 9600, 19200, 38400, 57600, 115200 bit/s
	Parity	None / even (default) / odd
	Slave addressing	1 to 247
Bus CANopen Slave	Contacts and connection	CIA401 compatible 2 connection points spring-type plug-in connection
	Data rate	20, 50, 100, 125, 250, 500, 800 kbits/s and 1 Mbits/s
	Slave addressing	1 to 127

12 Warranty

All our products are guaranteed for two years as of date of product manufacture (indicated on product), excluding wear parts. For the battery, the warranty period is limited to 1 year. Repair, modification or replacement of a device during the warranty period may not have the effect of extending the warranty period.

Limits of warranty:

The warranty does not cover defects resulting from:

- Transport,
- False manoeuvre or non-observance of connection diagrams when setting the equipment into service,
- Insufficient supervision or servicing, utilization not complying with the specifications detailed in the technical manual and, generally, storage, operation or environment conditions (atmospheric, chemical, electrical or other conditions).
- Conditions not specified on order of the equipment

The warranty shall not apply after any modifications or additions to the equipment performed by the customer without written approval by JAY Electronique.

The JAY Electronique responsibility during the warranty period is limited to material and construction defects. This warranty comprises repair in the JAY workshops or replacement, free of charge, of parts recognized to be defective following expert inspection by the Jay Technical Department.

The warranty shall not give rise to any compensation for damage claims

Any disputes related to a supply or settlement thereof shall be ruled by the COURT OF COMMERCE OF GRENOBLE, solely competent, even in the event of an Appeal or a plurality of defendants.

13 FCC Rules & Regulations (Federal Communications Commission)

The OEM integrators are responsible for ensuring that the end-user has no manual instructions to remove or install module.

Caution:

- The user that changes or modifications not expressly approved by **JAY Electronique** responsible for compliance could void the user's authority to operate the equipment.
- Any changes or modifications to this equipment not expressly approved by **JAY Electronique** may cause, harmful interference and void the FCC authorization to operate this equipment

This equipment has been tested and found to comply with the limits for a Class A digital device, pursuant to Part 15 of the FCC Rules. These limits are designed to provide reasonable protection against harmful interference when the equipment is operated in a commercial environment. This equipment generates, uses, and can radiate radio frequency energy and, if not installed and used in accordance with the instruction manual, may cause harmful interference to radio communications. Operation of this equipment in a residential area is likely to cause harmful interference in which case the user will be required to correct the interference at his own expense.

This portable equipment with its antenna complies with FCC's radiation exposure limits set forth for an uncontrolled environment. To maintain compliance, follow the instructions below:

1. This transmitter must not be co-located or operating in conjunction with any other antenna or transmitter.
2. Avoid direct contact to the antenna or keep contact to a minimum while using this equipment.

Authorized antennas: see chapter « Antennas »

Antenna installation requirements: see chapter « Installing the Receiver »

Radio module:

Depending on the model used, the product contains the module with FCC ID: OQMSB or OQMS5.

Warning:

This module is used exclusively by **JAY Electronique**. This product and the antennas must be professionally installed.

14 IC Regulations (Industry Canada)

The OEM integrators are responsible for ensuring that the end-user has no manual instructions to remove or install module.

This class (A) digital apparatus complies with Canadian ICES-003.

This portable equipment with its antenna complies with RSS102's radiation exposure limits set forth for an uncontrolled environment. To maintain compliance, follow the instructions below:

- 1. This transmitter must not be co-located or operating in conjunction with any other antenna or transmitter.*
- 2. Avoid direct contact to the antenna or keep contact to a minimum while using this equipment.*

This radio control (IC: 3393A-SB or IC: 3393A-S5 depending on product model) has been approved by Industry Canada to operate with the antenna types listed below with the maximum permissible gain and required antenna impedance for each antenna type indicated. Antenna types not included in this list, having a gain greater than the maximum gain indicated for that type, are strictly prohibited for use with this device.

Authorized antennas: see chapter « Antennas »

Antenna installation requirements: see chapter « Installing the Receiver »

This device complies with Industry Canada's licence-exempt RSSs.

Operation is subject to the following two conditions:

- 1. This device may not cause harmful interference; and*
- 2. This device must accept any interference received, including interference that may cause undesired operation of the device.*

Radio module:

Depending on the model used, the product contains the module with IC: 3393A-SB or 3393A-S5.

Warning:

*This modular is used exclusively by **JAY Electronique**. This module and the antennas must be professionally installed.*

15 TAIWAN NCC Regulations (National Communications Commission)

15.1 General; 一般的

Only products in band 2.4GHz are authorized by TAIWAN NCC.

Radio module:

The product contains the module with FCC ID: OQMS5.

Warning:

This modular is used exclusively by JAY Electronique. This module and the antennas must be professionally installed.

15.2 Regulations; 规定

Article 12

Without permission, any company, firm or user shall not alter the frequency, increase the power, or change the characteristics and functions of the original design of the certified lower power frequency electric machinery.

Article 14

The application of low power frequency electric machineries shall not affect the navigation safety nor interfere a legal communication, if an interference is found, the service will be suspended until improvement is made and the interference no longer exists.

第十二條

經型式認證合格之低功率射頻電機，非經許可，公司、商號或使用者均不得擅自變更頻率、加大功率或變更原設計之特性及功能。

第十四條

低功率射頻電機之使用不得影響飛航安全及干擾合法通信；經發現有干擾現象時，應立即停用，並改善至無干擾時方得繼續使用。前項合法通信，指依電信法規定作業之無線電通信。低功率射頻電機須忍受合法通信或工業、科學及醫療用電波輻射性電機設備之干擾。

15.3 Features; 特征

Frequency range 頻帶	2.4 GHz to 2.48 GHz
Numbers of channels 通道數	64
Channel bandwidth 信道帶寬	1.25MHz
Modulation type 無線電調制類型	DSSS
Data rate 數據速率	44.4 kb/s
Power level adjustable step 功率調整步數	10
RF power (regulation) 無線電功率	< 10 mW
Antenna 無線電天線	Internal antenna for operator module and both external antenna outputs for transceiver module (antenna diversity) 操作員模塊的內部天線和收發器模塊的兩個外部天線輸出 (天線分集)

16 Safety parameters

These products have been designed in compliance with the principles described in the standards mentioned below.

Functional tests, hardware and software failure tests and a detailed source code review were performed.



Please make sure to define RZ and RSF3 as safety relay to use the safety function "dual-way" input, safety button or Joystick.

Please, check the parameters of the product before start it. More information inside chapter 5.7.9.1 Procedure in iDialog user manual

The safety relevant actuators (dual ways, function button, joystick, safetybutton/Enabling switch) and life signal must be defined by iDialog. To know how to configure a safety input, please check the iDialog user manual.

16.1 Parameters calculated according to EN ISO 13849-1 and EN ISO 13849-2

Safety parameters have been calculated in accordance with EN ISO 13849-1, with a mission time of 20 years and the following assumptions:

Product		Parameters	Results
 Transmitter BETA	Emergency stop	B10 _D	250 000 cycles
		MTTF _d	100 years
		DC _{AVG}	99%
		Category	Cat. 4
		Performance level	PL e Hypothesis: d _{op} : 220d; h _{op} : 24h; t _{cycle} : 2800s
	"Dual way" input F1 to F6, N1, N2, A13	B10 _d	250 000 cycles
		MTTF _d	53.72 years
		DC _{AVG}	71.35%
		Category	Cat. 2
		Performance level	PL d Hypothesis: d _{op} : 220d; h _{op} : 24h; t _{cycle} : 300s

Product		Parameters	Results
 Transmitter GAMA	Emergency stop	B10 _D	250 000 cycles
		MTTF _d	100 years
		DC _{AVG}	99%
		Category	Cat. 4
		Performance level	PL e Hypothesis: d _{op} : 220d; h _{op} : 24h; t _{cycle} : 2800s
	Function buttons F1 to F10	B10 _D	1 000 000 cycles
		MTTF _d	100 years
		DC _{AVG}	94.72 %
		Category	Cat. 2
		Performance level	PL d Hypothesis: d _{op} : 220d; h _{op} : 24h; t _{cycle} : 600s
	"Dual way" input N1, N2	B10 _D	300 000 cycles
		MTTF _d	63.39 years
		DC _{AVG}	71.77%
		Category	Cat. 2
		Performance level	PL d Hypothesis: d _{op} : 220d; h _{op} : 24h; t _{cycle} : 300s

Product		Parameters	Results
Transmitter MOKA & PIKA 	Emergency stop	B10 _D	250 000 cycles
		MTTF _d	100 years
		DC _{AVG}	99%
		Category	Cat. 4
		Performance level	PL e Hypothesis: d _{op} : 220d; h _{op} : 24h; t _{cycle} : 3600s
	Joystick	B10 _D	3 000 000 cycles
		MTTF _d	100 years
		DC _{AVG}	85%
		Category	Cat. 2
		Performance level	PL d Hypothesis: d _{op} : 220d; h _{op} : 24h; t _{cycle} : 300s
	Joystick and "Dual way"	B10 _D	3 000 000 cycles
		MTTF _d	100 years
		DC _{AVG}	81.76%
		Category	Cat. 2
		Performance level	PL d Hypothesis: d _{op} : 220d; h _{op} : 24h; t _{cycle} : 300s
	Safety button / enable switch (A14)	B10 _D	1 000 000 cycles
		MTTF _d	91.7 years
		DC _{AVG}	93 %
		Category	Cat. 2
		Performance level	PL d Hypothesis: d _{op} : 220d; h _{op} : 24h; t _{cycle} : 300s
"Dual way" input F1 to F4, N1, N2, V1, V2, V3, C1_1, C1_2, A13	B10 _D	300 000 cycles	
	MTTF _d	54.7 years	
	DC _{AVG}	69 %	
	Category	Cat. 2	
	Performance level	PL d Hypothesis: d _{op} : 220d; h _{op} : 24h; t _{cycle} : 300s	

Product		Parameters	Results
Receiver ALTO 	Emergency stop	B10 _D	250 000 cycles
		MTTF _d	100 years
		DC _{AVG}	99%
		Category	Cat. 4
		Performance level	PL e Hypothesis: d _{op} : 220d; h _{op} : 24h; t _{cycle} : 3600s
	"Safety button"	B10 _D	250 000 cycles
		MTTF _d	100 years
		DC _{AVG}	94.72%
		Category	Cat. 2
		Performance level	PL d Hypothesis: d _{op} : 220d; h _{op} : 24h; t _{cycle} : 3600s
	Life signal (value are for both, transmitter and receiver side)/ safety function stop	B10 _D	250 000 cycles
		MTTF _d	59.08 years
		DC _{AVG}	67.69%
		Category	Cat. 2
		Performance level	PL d Hypothesis: d _{op} : 220d; h _{op} : 24h; t _{cycle} : 3600s

Product		Parameters	Results
Receiver ELIO 	Emergency stop	B10 _D	250 000 cycles
		MTTF _d	65.95 years
		DC _{AVG}	99%
		Category	Cat. 4
		Performance level	PL e Hypothesis: d _{op} : 220d; h _{op} : 24h; t _{cycle} : 3600s

Product		Parameters	Results
Receiver TIMO 	Emergency stop	B10 _D	250 000 cycles
		MTTF _d	54.6 years
		DC _{AVG}	99%
		Category	Cat. 4
		Performance level	PL e Hypothesis: d _{op} : 220d; h _{op} : 24h; t _{cycle} : 3600s

Product		Parameters	Results
Receiver NEMO 	Emergency stop	B10 _D	250 000 cycles
		MTTF _d	49,3 years
		DC _{AVG}	99%
		Category	Cat. 4
		Performance level	PL e Hypothesis: d _{op} : 220d; h _{op} : 24h; t _{cycle} : 3600s
	"Safety button"	B10 _D	250 000 cycles
		MTTF _d	41.1 years
		DC _{AVG}	99%
		Category	Cat. 2
		Performance level	PL d Hypothesis: d _{op} : 220d; h _{op} : 24h; t _{cycle} : 3600s
	Life signal (value are for both, transmitter and receiver side)/ safety function stop	B10 _D	250 000 cycles
		MTTF _d	41,1 years
		DC _{AVG}	99%
		Category	Cat. 2
		Performance level	PL d Hypothesis: d _{op} : 220d; h _{op} : 24h; t _{cycle} : 3600s

16.2 Parameters calculated according to EN 61508 and EN IEC 62061

Safety parameters have been calculated in accordance with EN 61508-6, with a mission time of 20 years and the following assumptions:

Product		Parameters	Results
Transmitter BETA 	Emergency stop	PFH _D	$6,29 \cdot 10^{-8}$ 1/h
		SSF	99%
		HFT	HFT 1
		SIL	SIL 3 Hypothesis: d _{op} : 220d; h _{op} : 24h; t _{cycle} : 2800s
	"Dual way" input F1 to F6, N1, N2, A13	PFH _D	$5,57 \cdot 10^{-7}$ 1/h
		SSF	60%
		HFT	HFT 0
		SIL	SIL 2 Hypothesis: d _{op} : 220d; h _{op} : 24h; t _{cycle} : 300s

Product		Parameters	Results
Transmitter GAMA 	Emergency stop	PFH _D	$9,86 \cdot 10^{-8}$ 1/h
		SSF	99%
		HFT	HFT 1
		SIL	SIL 3 Hypothesis: d _{op} : 220d; h _{op} : 24h; t _{cycle} : 2800s
	Function buttons F1 to F10	PFH _D	$1,62 \cdot 10^{-8}$ 1/h
		SSF	99%
		HFT	HFT 0
		SIL	SIL 2 Hypothesis: d _{op} : 220d; h _{op} : 24h; t _{cycle} : 600s
	"Dual way" input N1, N2	PFH _D	$1,47 \cdot 10^{-7}$ 1/h
		SSF	66.73%
		HFT	HFT 0
		SIL	SIL 2 Hypothesis: d _{op} : 220d; h _{op} : 24h; t _{cycle} : 300s

Product		Parameters	Results
	Emergency stop	PFH _D	1.92*10 ⁻⁸ 1/h
		SFF	99 %
		HFT	HFT 1
		SIL	SIL 3 Hypothesis: d _{op} : 220d; h _{op} : 24h; t _{cycle} : 2800s
	Joystick	PFH _D	4.17*10 ⁻⁸ 1/h
		SFF	77.82%
		HFT	HFT 0
		SIL	SIL 2 Hypothesis: d _{op} : 220d; h _{op} : 24h; t _{cycle} : 300s
	Joystick and "Dual way"	PFH _D	1.43*10 ⁻⁷ 1/h
		SFF	77.82%
		HFT	HFT 0
		SIL	SIL 2 Hypothesis: d _{op} : 220d; h _{op} : 24h; t _{cycle} : 300s
	Safety button / enable switch (A14)	PFH _D	8.31*10 ⁻⁸ 1/h
		SFF	90%
		HFT	HFT 0
		SIL	SIL 2 Hypothesis: d _{op} : 220d; h _{op} : 24h; t _{cycle} : 300s
	"Dual way" input F1 to F4, N1, N2, V1, V2, V3, C1_1, C1_2, A13	PFH _D	4.03*10 ⁻⁷ 1/h
		SFF	60%
		HFT	HFT 0
		SIL	SIL 2 Hypothesis: d _{op} : 220d; h _{op} : 24h; t _{cycle} : 300s

Product		Parameters	Results
	Emergency stop	PFH _D	4,86*10 ⁻⁹ 1/h
		SFF	99 %
		HFT	HFT 1
		SIL	SIL 3 Hypothesis: d _{op} : 220d; h _{op} : 24h; t _{cycle} : 3600s
	"Safety button"	PFH _D	1.33*10 ⁻⁷ 1/h
		SFF	92.61%
		HFT	HFT 0
		SIL	SIL 2 Hypothesis: d _{op} : 220d; h _{op} : 24h; t _{cycle} : 3600s
	Life signal (value are for both, transmitter and receiver side)/ safety function stop	PFH _D	2,6*10 ⁻⁷ 1/h
		SFF	67.69%
		HFT	HFT 0
		SIL	SIL 2 Hypothesis: d _{op} : 220d; h _{op} : 24h; t _{cycle} : 3600s

Product		Parameters	Results
Receiver ELIO 	Emergency stop	PFH _D	3,67*10 ⁻⁸ 1/h
		SFF	99%
		HFT	HFT 1
		SIL	SIL 3 Hypothesis: d _{op} : 220d; h _{op} : 24h; t _{cycle} : 3600s

Product		Parameters	Results
Receiver Timo 	Emergency stop	PFH _D	6,53*10 ⁻⁹ 1/h
		SFF	99 %
		HFT	HFT 1
		SIL	SIL 3 Hypothesis: d _{op} : 220d; h _{op} : 24h; t _{cycle} : 3600s

Product		Parameters	Results
Receiver Nemo 	Emergency stop	PFH _D	2,42*10 ⁻⁹ 1/h
		SFF	99%
		HFT	HFT 1
		SIL	SIL 3 Hypothesis: d _{op} : 220d; h _{op} : 24h; t _{cycle} : 3600s
	"Safety button"	PFH _D	1.73*10 ⁻⁸ 1/h
		SFF	99%
		HFT	HFT 0
		SIL	SIL 2 Hypothesis: d _{op} : 220d; h _{op} : 24h; t _{cycle} : 3600s
	Life signal (value are for both, transmitter and receiver side)/ safety function stop	PFH _D	1.73*10 ⁻⁸ 1/h
		SFF	99%
		HFT	HFT 0
		SIL	SIL 2 Hypothesis: d _{op} : 220d; h _{op} : 24h; t _{cycle} : 3600s

16.3 “Stop times” characteristics

A radio control system is considered as a machine control device and as a safety component used to stop a machine as specified by the EEC Machinery Directive. All applicable rules must therefore be observed to ensure safe, correct operation of such devices. Before the integration of the system, they do need to perform a hazard and risk analysis according to 2006/42/EC, to decide if the safety function and reaction time are sufficient for the application, and to decide the correct passive stopping time. This parameter is configurable by *iDialog* software.

Note1: Please make sur that *iDialog* is installed on a computer protected against viruses and with updated protection.

- **Active stop time:** The time stop active is between 174 to 894ms. The extreme value (894ms) corresponding when only the tenth radio frame from transmitter is received correctly.
- **Passive stop time:** The passive stop time is configurable between 300ms to 2s. The real value of passive time is equal to: Passive time parameter value + 110ms maximum.
Note: In the case of using special functions with two Receivers controlled by one transmitter, it is possible to configure different passive stopping times on each Receiver.
Note: The passive stop time can be set by iDialog.
- **Safety Relay function (RSF3 NEMO or RZ on ALTO):**
The time to release the safety relay function after release of the associated function button is equal to 378 ms without disturbance radio message.
If the radio message is disturbed, in this case the time of release the safety relay function is equal to the delay of passive time stop.
- **Safety function input:**
In case of failure of a safety input, the safety function relay will be opened in 675ms + passive stop max.
- **Life Signal**
Maximum delay between MT stops when configured in “Tandem” or “Master – Master”: 1189 ms
Maximum delay between MT stops when configured in “MultiDevices”: 170ms + 170ms x Nb MTs

The safety relevant actuators (dual ways, function button, joystick, safetybutton/Enabling switch) and life signal must be defined by iDialog. To know how to configure a safety input, please check the iDialog user manual.

16.4 Joystick command characteristic

A radio control system is considered as a machine control device and as a safety component used to stop function command as specified by the EEC Machinery Directive. All applicable rules must therefore be observed to ensure safe, correct operation of such devices. Before the integration of the system, they do need to perform a hazard and risk analysis according to 2006/42/EC, to decide if the joystick operation monitoring function are sufficient for the application, in accordance with the behavior described below.

Note:

- **Command between interval -2 to +2 of joystick’s step:** In this interval, the analog and step values are checked and if there are divergent, the analog and step values transmitted by the emiiter are equal to 0. In case of a discontinuous fault and a holding of the command, it’s possible that the analog output, corresponding at this command, can vary from 0 to 50% or -50%. And, the TOR output, corresponding to the joystick’s step, can also vary between 0 to 2 or -2. If the fault persists, you must stop the equipment and not use it while the joystick isn’t repaired.

In a worse-case condition, if analog and step values at the joystick have a divergence, it might occur that the analog output signal at the transceiver module switch from 0 to 50% immediately. The risk of such behaviour needs to be assessed for the final machine or system using this radio control system.
- **Command between interval < -2 to > +2 of joystick’s step:** In this interval, the analog and step values are checked and if there are divergent, the analog and step values transmitted by the emitter to the receiver are equal to 0. And it’s necessary to release the joystick at its central position to remove the fault detected. If the fault persists, you must stop the equipment and not use it while the joystick isn’t repaired.

17 Environmental characteristics

According to EN 62368-1:2014 + AC:2015:

NOTICE: This product has been designed for environment A. Use of this product may cause unwanted electromagnetic disturbances in which case the user may be required to take adequate mitigation measures.

Altitude of the site of installation does not exceed 2000 m.

The relative humidity of the air does not exceed 50 % at a maximum temperature of +40°C. Higher relative humidities may be permitted at lower temperatures, e.g. 90 % at + 20°C.

18 Residual risks

The product being an element of the equipment, a risk analysis of the application concerned will allow to estimate these residual risks.

19 Forseeable misuse

Polarity inversions of the Receiver power supply: no starting up of products.

Other misuse of the radio remote control system: see chapter *“Receiver indicator light functions and messages”*.

20 Product references

See product sales documentation.

21 Waste recycling and management



When the unit has reached the end of its service life, be sure to dispose of it appropriately. The unit can be disposed of in a specific waste collection centre as organised by the local authorities, or it can be turned over to a distributor who will handle proper disposal of the unit.

Electronic waste sorting will prevent a possible negative impact on the environment resulting from inappropriate elimination of electronic waste and will allow proper processing and recycling of the materials forming the unit, representing significant savings in terms of energy and resources.

22 Manufacturer information



Manufacturer and plant:

JAY Electronique
ZAC la Bâtie, 37 rue Champrond
F38334 SAINT ISMIER cedex

Tel: +33 (0)4 76 41 44 00
www.jay-electronique.com

23 Declarations EU of conformity

23.1 Beta – Declaration EU of conformity

Translated from French

EN

DECLARATION EU OF CONFORMITY

The manufacturer

JAY Electronique
ZAC la Bâtie, rue Champrond
38334 ST ISMIER Cedex
FRANCE

Declares that the following industrial radio remote :

BETA **JBxfzzz / PWCBxxx**

is in conformity with the requirements of the following directives and conformity was checked in accordance with the following standards :

Directives	Harmonised Standards & Other standards
DIRECTIVE 2006/42/EC OF THE EUROPEAN PARLIAMENT AND OF THE COUNCIL of 17 May 2006 on machinery, and amending Directive 95/16/EC	<i>EN ISO 13849-1 :2023 Requirements for performance level PL e (Category 4)</i> <i>EN 61508 :2010 Requirements for SIL 3</i> <i>EN IEC 62061 :2021 Requirements for SIL 3</i> <i>EN 60204-1 :2018 Clause 9.2.2 Stop category 0</i> <i>EN ISO 13850 :2015 Clause 4.1.3 Stop category 0</i>
Individual declaration of conformity	The wireless safety stop category 0, can be used in applications up to Category 4 (PLe) according to EN ISO 13849-1 :2023 and SIL 3 according to EN IEC 62061 :2021 and EN 61508 :2010 when associated with the appropriate transceiver module. The safety "dual-way" inputs control have a Performance Level (PL d) according to EN ISO 13849-1:2023 and SIL 2 according to EN IEC 62061:2021 and EN 61508:2010 when associated with the appropriate transceiver module.
Conformity evidence	The notified body No. 0044: TÜV NORD CERT GmbH Am TÜV 1 45307 Essen Germany Has issued an EC-Type examination n° 44 205 13199116 reflecting compliance with the standards
DIRECTIVE 2014/35/EU OF THE EUROPEAN PARLIAMENT AND OF THE COUNCIL of 26 February 2014 on the harmonisation of the laws of the Member States relating to the making available on the market of electrical equipment designed for use within certain voltage limits	<i>EN 62368-1 :2014 + A11 :2017</i> <i>EN 62479:2010</i>
DIRECTIVE 2014/30/EU OF THE EUROPEAN PARLIAMENT AND OF THE COUNCIL of 26 February 2014 on the harmonisation of the laws of the Member States relating to electromagnetic compatibility (recast)	<i>EN IEC 62061 :2021 §6.6</i> <i>EN 301 489,3 V2.1.1</i> <i>EN 301 489-1 V2.2.3</i> <i>EN 61000-6-2:2005</i> <i>IEC 61000-6-2:2016</i> <i>EN 61000-6-7:2015</i> <i>EN 61326-3-1:2017</i> <i>EN 61326-1:2013</i>
DIRECTIVE 2014/53/EU OF THE EUROPEAN PARLIAMENT AND OF THE COUNCIL of 16 April 2014 on the harmonisation of the laws of the Member States relating to the making available on the market of radio equipment and repealing Directive 1999/5/EC	<i>EN 300 220-2 V3.1.1</i> <ul style="list-style-type: none"><i>frequency Band 433.05-434.79 MHz</i><i>frequency Band 869.7-870 MHz</i> <i>EN 300 440 V2.2.1</i> <ul style="list-style-type: none"><i>frequency Band 2.4GHz</i>
DIRECTIVE 2011/65/EU OF THE EUROPEAN PARLIAMENT AND OF THE COUNCIL of 8 June 2011 related to the limitation of use of certain dangerous substances in electrical and electronic equipment (RoHS)	
DIRECTIVE 2012/19/EU OF THE EUROPEAN PARLIAMENT AND OF THE COUNCIL of 4 July 2012 related to electrical and electronic equipment waste (WEEE)	

It is important that the component is subject to correct installation, maintenance and use conforming to its intended purpose, to the applicable regulations and standards, to the supplier's instructions, user manual and to the accepted rules of the art.

Name, function and address of the person authorised to compile the technical file:
Laurent Damon, R&D Manager - JAY Electronique ZAC la Bâtie, rue Champrond 38334 St Ismier-France

Issued at: Saint Ismier, FRANCE, 2025/01/06.

Signature: *signed on original*

351900G

23.2 Gama – Declaration EU of conformity

Translated from French



DECLARATION EU OF CONFORMITY

The manufacturer

JAY Electronique
ZAC la Bâtie, rue Champrond
38334 ST ISMIER Cedex
FRANCE

Declares that the following industrial radio remote :

GAMA **JGxfzzz / PWCGxxx**

is in conformity with the requirements of the following directives and conformity was checked in accordance with the following standards :

Directives	Harmonised Standards & Other standards
DIRECTIVE 2006/42/EC OF THE EUROPEAN PARLIAMENT AND OF THE COUNCIL of 17 May 2006 on machinery, and amending Directive 95/16/EC	<i>EN ISO 13849-1 :2023 Requirements for performance level PL e (Category 4)</i> <i>EN 61508 :2010 Requirements for SIL 3</i> <i>EN IEC 62061 :2021 Requirements for SIL 3</i> <i>EN 60204-1 :2018 Clause 9.2.2 Stop category 0</i> <i>EN ISO 13850 :2015 Clause 4.1.3 Stop category 0</i>
Individual declaration of conformity	The wireless safety stop category 0, can be used in applications up to Category 4 (PL e) according to EN ISO 13849-1 :2023 and SIL 3 according to EN 62061 :2021 and EN 61508 :2010 when associated with the appropriate transceiver module.
Conformity evidence	The safety “dual-way” inputs and safety button control have a Performance Level (PL d) according to EN ISO 13849-1:2023 and SIL 2 according to EN IEC 62061:2021 and EN 61508:2010 when associated with the appropriate transceiver module. The notified body No. 0044: TÜV NORD CERT GmbH Am TÜV 1 45307 Essen Germany Has issued an EC-Type examination n° 44 205 13199117 reflecting compliance with the standards
DIRECTIVE 2014/35/EU OF THE EUROPEAN PARLIAMENT AND OF THE COUNCIL of 26 February 2014 on the harmonisation of the laws of the Member States relating to the making available on the market of electrical equipment designed for use within certain voltage limits	<i>EN 62368-1 :2014 + A11 :2017</i> <i>EN 62479:2010</i>
DIRECTIVE 2014/30/EU OF THE EUROPEAN PARLIAMENT AND OF THE COUNCIL of 26 February 2014 on the harmonisation of the laws of the Member States relating to electromagnetic compatibility (recast)	<i>EN IEC 62061 :2021 §6.6</i> <i>EN 301 489-3 V2.1.1</i> <i>EN 301 489-1 V2.2.3</i> <i>EN 61000-6-2:2005</i> <i>IEC 61000-6-2:2016</i> <i>EN 61000-6-7:2015</i> <i>EN 61326-3-1:2017</i> <i>EN 61326-1:2013</i>
DIRECTIVE 2014/53/EU OF THE EUROPEAN PARLIAMENT AND OF THE COUNCIL of 16 April 2014 on the harmonisation of the laws of the Member States relating to the making available on the market of radio equipment and repealing Directive 1999/5/EC	<i>EN 300 220-2 V3.1.1</i> <ul style="list-style-type: none"> • frequency Band 433.05-434.79 MHz • frequency Band 869.7-870 MHz <i>EN 300 440 V2.2.1</i> <ul style="list-style-type: none"> • frequency Band 2.4GHz
DIRECTIVE 2011/65/EU OF THE EUROPEAN PARLIAMENT AND OF THE COUNCIL of 8 June 2011 related to the limitation of use of certain dangerous substances in electrical and electronic equipment (RoHS)	
DIRECTIVE 2012/19/EU OF THE EUROPEAN PARLIAMENT AND OF THE COUNCIL of 4 July 2012 related to electrical and electronic equipment waste (WEEE)	

It is important that the component is subject to correct installation, maintenance and use conforming to its intended purpose, to the applicable regulations and standards, to the supplier's instructions, user manual and to the accepted rules of the art.

Name, function and address of the person authorised to compile the technical file:
 Lauren Damon, R&D Manager - JAY Electronique ZAC la Bâtie, rue Champrond 38334 St Ismier-France

Issued at: Saint Ismier, FRANCE, 2025/01/06.

Signature: *signed on original*

351901G

23.3 Moka – Declaration EU of conformity

Translated from French



DECLARATION EU OF CONFORMITY

The manufacturer

JAY Electronique
ZAC la Bâtie, rue Champrond
38334 ST ISMIER Cedex
FRANCE

Declares that the following industrial radio remote :

MOKA **JMxfzzz / PWCxxxx**

is in conformity with the requirements of the following directives and conformity was checked in accordance with the following standards :

Directives	Harmonised Standards & Other standards
DIRECTIVE 2006/42/EC OF THE EUROPEAN PARLIAMENT AND OF THE COUNCIL of 17 May 2006 on machinery, and amending Directive 95/16/EC	<i>EN ISO 13849-1 :2023 Requirements for performance level PL e (Category 4)</i> <i>EN 61508 :2010 Requirements for SIL 3</i> <i>EN IEC 62061 :2021 Requirements for SIL 3</i> <i>EN 60204-1 :2018 Clause 9.2.2 Stop category 0</i> <i>EN ISO 13850 :2015 Clause 4.1.3 Stop category 0</i>
Individual declaration of conformity	The wireless safety stop category 0, can be used in applications up to Category 4 (PLe) according to EN ISO 13849-1 :2023 and SIL 3 according to EN IEC 62061 :2021 and EN 61508 :2010 when associated with the appropriate transceiver module. The safety “dual-way” inputs, joystick, safety button and enabling switch have a Performance Level (PL d) according to EN ISO 13849-1:2023 and SIL 2 according to EN IEC 62061:2021 and EN 61508:2010 when associated with the appropriate transceiver module.
Conformity evidence	The notified body No. 0044: TÜV NORD CERT GmbH Am TÜV 1 45307 Essen Germany Has issued an EC-Type examination n° 44 205 13199118 reflecting compliance with the standards
DIRECTIVE 2014/35/EU OF THE EUROPEAN PARLIAMENT AND OF THE COUNCIL of 26 February 2014 on the harmonisation of the laws of the Member States relating to the making available on the market of electrical equipment designed for use within certain voltage limits	<i>EN 62368-1 :2014 + A11 :2017</i> <i>EN 62479:2010</i>
DIRECTIVE 2014/30/EU OF THE EUROPEAN PARLIAMENT AND OF THE COUNCIL of 26 February 2014 on the harmonisation of the laws of the Member States relating to electromagnetic compatibility (recast)	<i>EN IEC 62061 : 2021 §6.6</i> <i>EN 301 489-3 V2.1.1</i> <i>EN 301 489-1 V2.2.3</i> <i>EN 61000-6-2:2005</i> <i>IEC 61000-6-2:2016</i> <i>EN 61000-6-7:2015</i> <i>EN 61326-3-1:2017</i> <i>EN 61326-1:2013</i>
DIRECTIVE 2014/53/EU OF THE EUROPEAN PARLIAMENT AND OF THE COUNCIL of 16 April 2014 on the harmonisation of the laws of the Member States relating to the making available on the market of radio equipment and repealing Directive 1999/5/EC	<i>EN 300 220-2 V3.1.1</i> <ul style="list-style-type: none"> • frequency Band 433.05-434.79 MHz • frequency Band 869.7-870 MHz <i>EN 300 440 V2.2.1</i> <ul style="list-style-type: none"> • frequency Band 2.4 GHz
DIRECTIVE 2011/65/EU OF THE EUROPEAN PARLIAMENT AND OF THE COUNCIL of 8 June 2011 related to the limitation of use of certain dangerous substances in electrical and electronic equipment (RoHS)	
DIRECTIVE 2012/19/EU OF THE EUROPEAN PARLIAMENT AND OF THE COUNCIL of 4 July 2012 related to electrical and electronic equipment waste (WEEE)	

It is important that the component is subject to correct installation, maintenance and use conforming to its intended purpose, to the applicable regulations and standards, to the supplier's instructions, user manual and to the accepted rules of the art.

Name, function and address of the person authorised to compile the technical file:
 Laurent Damon, R&D Manager - JAY Electronique ZAC la Bâtie, rue Champrond 38334 St Ismier-France

Issued at: Saint Ismier, FRANCE, 2025/01/06.

Signature: *signed on original*

351902G

23.4 Pika – Declaration EU of conformity

Translated from French

EN

DECLARATION EU OF CONFORMITY

The manufacturer

JAY Electronique
ZAC la Bâtie, rue Champrond
38334 ST ISMIER Cedex
FRANCE

Declares that the following industrial radio remote :

PIKA
JPxfzzz / PWCxxxx

is in conformity with the requirements of the following directives and conformity was checked in accordance with the following standards :

Directives	Harmonised Standards & Other standards
DIRECTIVE 2006/42/EC OF THE EUROPEAN PARLIAMENT AND OF THE COUNCIL of 17 May 2006 on machinery, and amending Directive 95/16/EC	EN ISO 13849-1 :2023 Requirements for performance level PL e (Category 4) EN 61508 :2010 Requirements for SIL 3 EN IEC 62061 :2021 Requirements for SIL 3 EN 60204-1 :2018 Clause 9.2.2 Stop category 0 EN ISO 13850 :2015 Clause 4.1.3 Stop category 0
Individual declaration of conformity	The wireless safety stop category 0, can be used in applications up to Category 4 (PLe) according to EN ISO 13849-1 :2023 and SIL 3 according to EN IEC 62061 :2021 and EN 61508 :2010 when associated with the appropriate transceiver module. The safety "dual-way" inputs, joystick, safety button and enabling switch have Performance Level (PL d) according to EN ISO 13849-1:2023 and SIL 2 according to EN IEC 62061:2021 and EN 61508:2010 when associated with the appropriate transceiver module.
Conformity evidence	The notified body No. 0044: TÜV NORD CERT GmbH Am TÜV 1 45307 Essen Germany Has issued an EC-Type examination n° 44 205 13199119 reflecting compliance with the standards
DIRECTIVE 2014/35/EU OF THE EUROPEAN PARLIAMENT AND OF THE COUNCIL of 26 February 2014 on the harmonisation of the laws of the Member States relating to the making available on the market of electrical equipment designed for use within certain voltage limits	EN 62368-1 :2014 + A11 :2017 EN 62479:2010
DIRECTIVE 2014/30/EU OF THE EUROPEAN PARLIAMENT AND OF THE COUNCIL of 26 February 2014 on the harmonisation of the laws of the Member States relating to electromagnetic compatibility (recast)	EN IEC 62061 : 2021 §6.6 EN 301 489-3 V2.1.1 EN 301 489-1 V2.2.3 EN 61000-6-2:2005 IEC 61000-6-2:2016 EN 61000-6-7:2015 EN 61326-3-1:2017 EN 61326-1:2013
DIRECTIVE 2014/53/EU OF THE EUROPEAN PARLIAMENT AND OF THE COUNCIL of 16 April 2014 on the harmonisation of the laws of the Member States relating to the making available on the market of radio equipment and repealing Directive 1999/5/EC	EN 300 220-2 V3.1.1 <ul style="list-style-type: none"> • frequency Band 433.05-434.79 MHz • frequency Band 869.7-870 MHz EN 300 440 V2.2.1 <ul style="list-style-type: none"> • frequency Band 2.4GHz
DIRECTIVE 2011/65/EU OF THE EUROPEAN PARLIAMENT AND OF THE COUNCIL of 8 June 2011 related to the limitation of use of certain dangerous substances in electrical and electronic equipment (RoHS)	
DIRECTIVE 2012/19/EU OF THE EUROPEAN PARLIAMENT AND OF THE COUNCIL of 4 July 2012 related to electrical and electronic equipment waste (WEEE)	

It is important that the component is subject to correct installation, maintenance and use conforming to its intended purpose, to the applicable regulations and standards, to the supplier's instructions, user manual and to the accepted rules of the art.

Name, function and address of the person authorised to compile the technical file:
 Laurent Damon, R&D Manager - JAY Electronique ZAC la Bâtie, rue Champrond 38334 St Ismier-France

Issued at: Saint Ismier, FRANCE, 2025/01/06.

Signature: *signed on original*

351903G

23.5 Alto – Declaration EU of conformity

Translated from French



DECLARATION EU OF CONFORMITY

The manufacturer

JAY Electronique
ZAC la Bâtie, rue Champrond
38334 ST ISMIER Cedex
FRANCE

Declares that the following transceiver module :

ALTO
XAXXXX

is in conformity with the requirements of the following directives and conformity was checked in accordance with the following standards :

Directives	Harmonised Standards & Other standards
DIRECTIVE 2006/42/EC OF THE EUROPEAN PARLIAMENT AND OF THE COUNCIL of 17 May 2006 on machinery, and amending Directive 95/16/EC	<i>EN ISO 13849-1 :2023 Requirements for performance level PLe (Category 4)</i> <i>EN 61508 :2010 Requirements for SIL 3</i> <i>EN IEC 62061 :2021 Requirements for SIL 3</i> <i>EN ISO 13850 :2015 Clause 4.1.3 Stop category 0</i>
Individual declaration of conformity	This hardware can be used in applications up to Category 4 (PLe) according to EN ISO 13849-1 :2023 and SIL 3 according to EN IEC 62061 :2021 and EN 61508 :2010 when associated with the appropriate operator module. This hardware can be used in applications up to Category 2 (PLd) according to EN ISO 13849-1 :2023 and SIL 2 according to EN IEC 62061 :2021 and EN 61508 :2010 when associated with the appropriate operator module.
Conformity evidence	The notified body No. 0044: TÜV NORD CERT GmbH Am TÜV 1 45307 Essen Germany Has issued an EC-Type examination n° 44 205 13199120 reflecting compliance with the standards
DIRECTIVE 2014/35/EU OF THE EUROPEAN PARLIAMENT AND OF THE COUNCIL of 26 February 2014 on the harmonisation of the laws of the Member States relating to the making available on the market of electrical equipment designed for use within certain voltage limits	<i>EN 62368-1:2014 + A11:2017</i> <i>EN 62479:2010</i>
DIRECTIVE 2014/30/EU OF THE EUROPEAN PARLIAMENT AND OF THE COUNCIL of 26 February 2014 on the harmonisation of the laws of the Member States relating to electromagnetic compatibility (recast)	<i>EN IEC 62061 : 2021 §6.6</i> <i>EN 301 489-3 V2.1.1</i> <i>EN 301 489-1 V2.2.3</i> <i>EN 61000-6-2:2005</i> <i>IEC 61000-6-2:2016</i> <i>EN 61000-6-7:2015</i> <i>EN 61326-3-1:2017</i> <i>EN 61326-1:2013</i>
DIRECTIVE 2014/53/EU OF THE EUROPEAN PARLIAMENT AND OF THE COUNCIL of 16 April 2014 on the harmonisation of the laws of the Member States relating to the making available on the market of radio equipment and repealing Directive 1999/5/EC	<i>EN 300 220-2 V3.2.1</i> <ul style="list-style-type: none"> frequency Band 433.05-434.79 MHz frequency Band 869.7-870 MHz <i>EN 300 440 V2.2.1</i> <ul style="list-style-type: none"> frequency Band 2.4GHz
DIRECTIVE 2011/65/EU OF THE EUROPEAN PARLIAMENT AND OF THE COUNCIL of 8 June 2011 related to the limitation of use of certain dangerous substances in electrical and electronic equipment (RoHS)	
DIRECTIVE 2012/19/EU OF THE EUROPEAN PARLIAMENT AND OF THE COUNCIL of 4 July 2012 related to electrical and electronic equipment waste (WEEE)	

It is important that the component is subject to correct installation, maintenance and use conforming to its intended purpose, to the applicable regulations and standards, to the supplier's instructions, user manual and to the accepted rules of the art.

Name, function and address of the person authorised to compile the technical file:
 Laurent Damon, R&D Manager - JAY Electronique ZAC la Bâtie, rue Champrond 38334 St Ismier-France

Issued at: Saint Ismier, FRANCE, 2025/01/06.

Signature: *signed on original*

351904G

23.6 Elio – Declaration EU of conformity

Translated from French



DECLARATION EU OF CONFORMITY

The manufacturer

JAY Electronique
ZAC la Bâtie, rue Champrond
38334 ST ISMIER Cedex
FRANCE

Declares that for following transceiver module :

ELIO
xEXXXXX

is in conformity with the requirements of the following directives and conformity was checked in accordance with the following standards :

Directives	Harmonised Standards & Other standards
DIRECTIVE 2006/42/EC OF THE EUROPEAN PARLIAMENT AND OF THE COUNCIL of 17 May 2006 on machinery, and amending Directive 95/16/EC	<i>EN ISO 13849-1 :2023 Requirements for performance level PL e (Category 4)</i> <i>EN 61508 :2010 Requirements for SIL 3</i> <i>EN IEC 62061 :2023 Requirements for SIL 3</i> <i>EN ISO 13850 :2015 Clause 4.1.3 Stop category 0</i>
Individual declaration of conformity	This hardware can be used in applications up to Category 4 (PLe) according to EN ISO 13849-1 :2023 and SIL 3 according to EN IEC 62061 :2021 and EN 61508 :2010 when associated with the appropriate operator module.
Conformity evidence	The notified body No. 0044: TÜV NORD CERT GmbH Am TÜV 1 45307 Essen Germany Has issued an EC-Type examination n° 44 205 13199121 reflecting compliance with the standards
DIRECTIVE 2014/35/EU OF THE EUROPEAN PARLIAMENT AND OF THE COUNCIL of 26 February 2014 on the harmonisation of the laws of the Member States relating to the making available on the market of electrical equipment designed for use within certain voltage limits	<i>EN 62368-1 :2014 + A11 :2017</i> <i>EN 62479:2010</i>
DIRECTIVE 2014/30/EU OF THE EUROPEAN PARLIAMENT AND OF THE COUNCIL of 26 February 2014 on the harmonisation of the laws of the Member States relating to electromagnetic compatibility (recast)	<i>EN IEC 62061 :2021 §6.6</i> <i>EN 301 489-3 V2.1.1</i> <i>EN 301 489-1 V2.2.3</i> <i>EN 61000-6-2:2005</i> <i>IEC 61000-6-2:2016</i> <i>EN 61000-6-7:2015</i> <i>EN 61326-3-1:2017</i> <i>EN 61326-1:2013</i>
DIRECTIVE 2014/53/EU OF THE EUROPEAN PARLIAMENT AND OF THE COUNCIL of 16 April 2014 on the harmonisation of the laws of the Member States relating to the making available on the market of radio equipment and repealing Directive 1999/5/EC	<i>EN 300 220-2 V3.1.1</i> <ul style="list-style-type: none"> frequency Band 433.05-434.79 MHz frequency Band 869.7-870 MHz <i>EN 300 440 V2.2.1</i> <ul style="list-style-type: none"> frequency Band 2.4GHz
DIRECTIVE 2011/65/EU OF THE EUROPEAN PARLIAMENT AND OF THE COUNCIL of June 2011 related to the limitation of use of certain dangerous substances in electrical and electronic equipment (RoHS)	
DIRECTIVE 2012/19/EU OF THE EUROPEAN PARLIAMENT AND OF THE COUNCIL of July 2012 related to electrical and electronic equipment waste (WEEE)	

It is important that the component is subject to correct installation, maintenance and use conforming to its intended purpose, to the applicable regulations and standards, to the supplier's instructions, user manual and to the accepted rules of the art.

Name, function and address of the person authorised to compile the technical file:

Laurent Damon, R&D Manager - JAY Electronique ZAC la Bâtie, rue Champrond 38334 St Ismier-France

Issued at: Saint Ismier, FRANCE, 2025/01/06.

Signature: *signed on original*

351905G

23.7 Timo – Declaration EU of conformity

Translated from French



DECLARATION EU OF CONFORMITY

The manufacturer

JAY Electronique
ZAC la Bâtie, rue Champrond
38334 ST ISMIER Cedex
FRANCE

Declares that the following transceiver module :

TIMO
xTxxxxx

is in conformity with the requirements of the following directives and conformity was checked in accordance with the following standards :

Directives	Harmonised Standards & Other standards
DIRECTIVE 2006/42/EC OF THE EUROPEAN PARLIAMENT AND OF THE COUNCIL of 17 May 2006 on machinery, and amending Directive 95/16/EC	<i>EN ISO 13849-1 :2023 Requirements for performance level PL e (Category 4)</i> <i>EN 61508 :2010 Requirements for SIL 3</i> <i>EN IEC 62061 :2021 Requirements for SIL 3</i> <i>EN ISO 13850 :2015 Clause 4.1.3 Stop category 0</i>
Individual declaration of conformity	This hardware can be used in applications up to Category 4 (PL e) according to EN ISO 13849-1 :2023 and SIL 3 according to EN IEC 62061 :2021 and EN 61508 :2010 when associated with the appropriate operator module.
Conformity evidence	The notified body No. 0044: TÜV NORD CERT GmbH Am TÜV 1 45307 Essen Germany Has issued an EC-Type examination n° 44 205 13199124 reflecting compliance with the standards
DIRECTIVE 2014/35/EU OF THE EUROPEAN PARLIAMENT AND OF THE COUNCIL of 26 February 2014 on the harmonisation of the laws of the Member States relating to the making available on the market of electrical equipment designed for use within certain voltage limits	<i>EN 62368-1:2014 + A11:2017</i> <i>EN 62479:2010</i>
DIRECTIVE 2014/30/EU OF THE EUROPEAN PARLIAMENT AND OF THE COUNCIL of 26 February 2014 on the harmonisation of the laws of the Member States relating to electromagnetic compatibility (recast)	<i>EN IEC 62061 : 2021 §6.6</i> <i>EN 301 489-3 V2.1.1</i> <i>EN 301 489-1 V2.2.3</i> <i>EN 61000-6-2:2005</i> <i>IEC 61000-6-2:2016</i> <i>EN 61000-6-7:2015</i> <i>EN 61326-3-1:2017</i> <i>EN 61326-1:2013</i>
DIRECTIVE 2014/53/EU OF THE EUROPEAN PARLIAMENT AND OF THE COUNCIL of 16 April 2014 on the harmonisation of the laws of the Member States relating to the making available on the market of radio equipment and repealing Directive 1999/5/EC	<i>EN 300 220-2 V3.2.1</i> <ul style="list-style-type: none"> • <i>frequency Band 433.05-434.79 MHz</i> • <i>frequency Band 869.7-870 MHz</i> <i>EN 300 440 V2.2.1</i> <ul style="list-style-type: none"> • <i>frequency Band 2.4GHz</i>
DIRECTIVE 2011/65/EU OF THE EUROPEAN PARLIAMENT AND OF THE COUNCIL of 8 June 2011 related to the limitation of use of certain dangerous substances in electrical and electronic equipment (RoHS)	
DIRECTIVE 2012/19/EU OF THE EUROPEAN PARLIAMENT AND OF THE COUNCIL of 4 July 2012 related to electrical and electronic equipment waste (WEEE)	

It is important that the component is subject to correct installation, maintenance and use conforming to its intended purpose, to the applicable regulations and standards, to the supplier's instructions, user manual and to the accepted rules of the art.

Name, function and address of the person authorised to compile the technical file:
 Laurent Damon, R&D Manager - JAY Electronique ZAC la Bâtie, rue Champrond 38334 St Ismier-France

Issued at: Saint Ismier, FRANCE, 2025/01/06.

Signature: *signed on original*

351906G

23.8 Nemo – Declaration EU of conformity

Translated from French



DECLARATION EU OF CONFORMITY

The manufacturer

JAY Electronique
ZAC la Bâtie, rue Champrond
38334 ST ISMIER Cedex
FRANCE

Declares that the following transceiver module :

NEMO
xNXXXXX

is in conformity with the requirements of the following directives and conformity was checked in accordance with the following standards :

Directives	Harmonised Standards & Other standards
DIRECTIVE 2006/42/EC OF THE EUROPEAN PARLIAMENT AND OF THE COUNCIL of 17 May 2006 on machinery, and amending Directive 95/16/EC	<i>EN ISO 13849-1 :2023 Requirements for performance level PL e (Category 4)</i> <i>EN 61508 :2010 Requirements for SIL 3</i> <i>EN IEC 62061 :2021 Requirements for SIL 3</i>
Individual declaration of conformity	This hardware can be used in applications up to Category 4 (PL e) according to EN ISO 13849-1 :2023 and SIL 3 according to EN IEC 62061 :2021 and EN 61508 :2010 when associated with the appropriate operator module. This hardware can be used in applications up to Category 2 (PL d) according to EN ISO 13849-1:2023 and SIL 2 according to EN IEC 62061:2021 and EN 61508:2010 for its safety function output, when associated with the appropriate operator module.
Conformity evidence	The notified body No. 0044: TÜV NORD CERT GmbH Am TÜV 1 45307 Essen Germany Has issued an EC-Type examination n° 44 205 13199113 reflecting compliance with the standards
DIRECTIVE 2014/35/EU OF THE EUROPEAN PARLIAMENT AND OF THE COUNCIL of 26 February 2014 on the harmonisation of the laws of the Member States relating to the making available on the market of electrical equipment designed for use within certain voltage limits	<i>EN 62368-1:2014 + AC:2015</i> <i>EN 62479:2010</i>
DIRECTIVE 2014/30/EU OF THE EUROPEAN PARLIAMENT AND OF THE COUNCIL of 26 February 2014 on the harmonisation of the laws of the Member States relating to electromagnetic compatibility (recast)	<i>EN IEC 62061 : 2021 §6.6</i> <i>EN 301 489-3 V2.1.1</i> <i>EN 301 489-1 V2.2.3</i> <i>EN 61000-6-2:2005</i> <i>IEC 61000-6-2:2016</i> <i>EN 61000-6-7:2015</i> <i>EN 61326-3-1:2017</i> <i>EN 61326-1:2013</i>
DIRECTIVE 2014/53/EU OF THE EUROPEAN PARLIAMENT AND OF THE COUNCIL of 16 April 2014 on the harmonisation of the laws of the Member States relating to the making available on the market of radio equipment and repealing Directive 1999/5/EC	<i>EN 300 220-2 V3.2.1</i> <ul style="list-style-type: none"> <i>frequency Band 433.05-434.79 MHz</i> <i>frequency Band 869.7-870 MHz</i> <i>EN 300 440 V2.2.1</i> <ul style="list-style-type: none"> <i>frequency Band 2.4GHz</i>
DIRECTIVE 2011/65/EU OF THE EUROPEAN PARLIAMENT AND OF THE COUNCIL of 8 June 2011 related to the limitation of use of certain dangerous substances in electrical and electronic equipment (RoHS)	
DIRECTIVE 2012/19/EU OF THE EUROPEAN PARLIAMENT AND OF THE COUNCIL of 4 July 2012 related to electrical and electronic equipment waste (WEEE)	

It is important that the component is subject to correct installation, maintenance and use conforming to its intended purpose, to the applicable regulations and standards, to the supplier's instructions, user manual and to the accepted rules of the art.

Name, function and address of the person authorised to compile the technical file:
 Laurent Damon, R&D Manager - JAY Electronique ZAC la Bâtie, rue Champrond 38334 St Ismier-France

Issued at: Saint Ismier, FRANCE, 2025/01/14.

Signature: *signed on original*

353170F



JAY Electronique
ZAC la Bâtie, 37 rue Champrond
F38334 SAINT ISMIER cedex

Tel: +33 (0)4 76 41 44 00
www.jay-electronique.com