

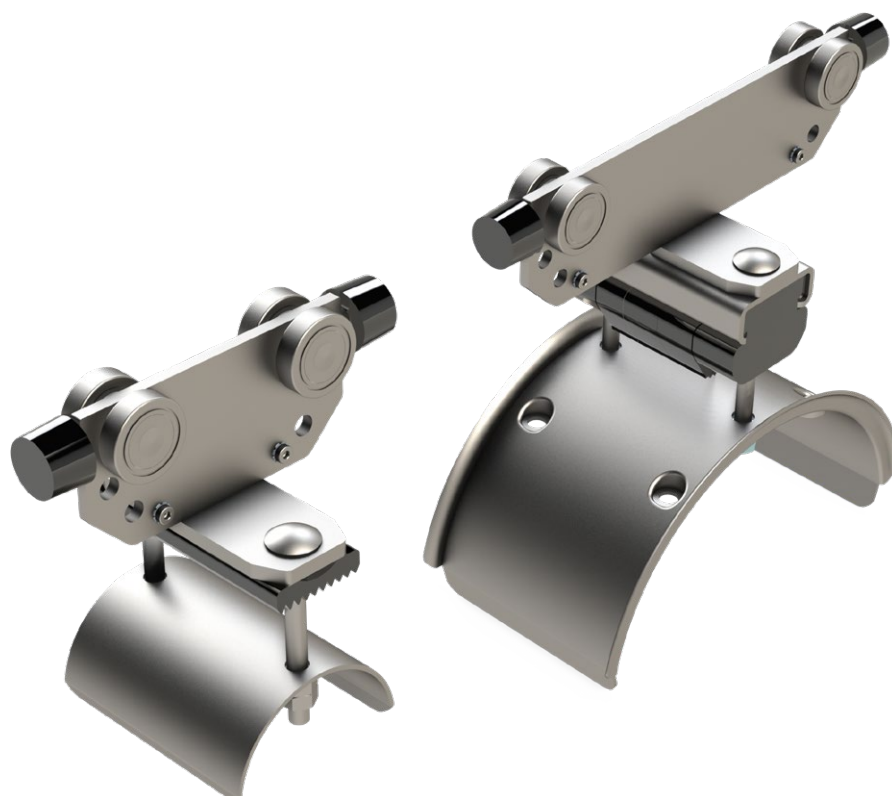

Festoon Systems for C-Rails Program 0240EX



ATEX – Introduction

General Notes

Our ATEX festoon systems are comprised of standard parts from our 0230 and 0240 programs – plus ATEX components. ATEX festoon systems can be expanded with standard 0230 and 0240 parts.

However, for ATEX applications there are some specifics to be taken into account:

Maximum running speed:

Conductix-Wampfler festoon systems according to ATEX are only to be used with a maximum speed of 1m/s!
Explosion protection becomes void when this speed limit is exceeded.

Cables and hoses:

Outer sheaths must be made from the following materials:

- Heavy polychloroprene or some similar synthetic elastomer
- Heavy rubber hoses or connecting cables of an equally robust composition
- No PVC cables/hoses!

Grounding:

To avoid any potential ignition processes, all chargeable conductive parts must be grounded.
All metal components of the festoon system are conductively connected. Additionally, the rail is grounded.

Electrical accessory equipment:

Accessory equipment supplied by the customer, such as junction boxes on control unit trolleys or teach pendants must be eligible for use in zones 1 and 21.
Respective product guides must be collected by the customer and added to the festoon system's documentation.

Conductix-Wampfler Festoon Systems according to ATEX – Areas of Application

• Mines and Mine Damp

No zones allocated		 WARNING! Operation not permitted
--------------------	--	--

• Other Areas with Potentially Explosive Atmosphere – Gas

Zone 0	Potentially explosive atmosphere present continuously or for long periods or frequently	 WARNING! Operation not permitted
Zone 1	Potentially explosive atmosphere likely to occur in normal operation occasionally	Operation permitted
Zone 2	Potentially explosive atmosphere not likely to occur in normal operation but, if it does occur, will persist for a short period only	Operation permitted

• Other Potentially Explosive Areas – Powder/Dust

Zone 20	Potentially explosive atmosphere present continuously or for long periods or frequently	 WARNING! Operation not permitted
Zone 21	Potentially explosive atmosphere likely to occur in normal operation occasionally	Operation permitted
Zone 22	Potentially explosive atmosphere not likely to occur in normal operation but, if it does occur, will persist for a short period only	Operation permitted

Contents

ATEX – Introduction

General Notes	2
Conductix-Wampfler Festoon Systems according to ATEX – Areas of Application	2

System Layout

Program 0240 for ATEX

Festoon System with Towing Trolley.....	4
Festoon System with Control Unit Trolley.....	4

ATEX Accessories

Program 0240 for ATEX

Protective Conductor	5
Protective Conductor Connection	5
Tension Relief Rope/Potential Equalization	5
Ground Terminal Clamp	5
Rail Connector.....	5
Cable Trolley for Flat Cables Program 0240EX	6
Cable Trolley for Round Cables Program 0240EX.....	7
Control Unit Trolley Program 0240EX.....	7

System Layout Program 0240 for ATEX

Festoon System with Towing Trolley

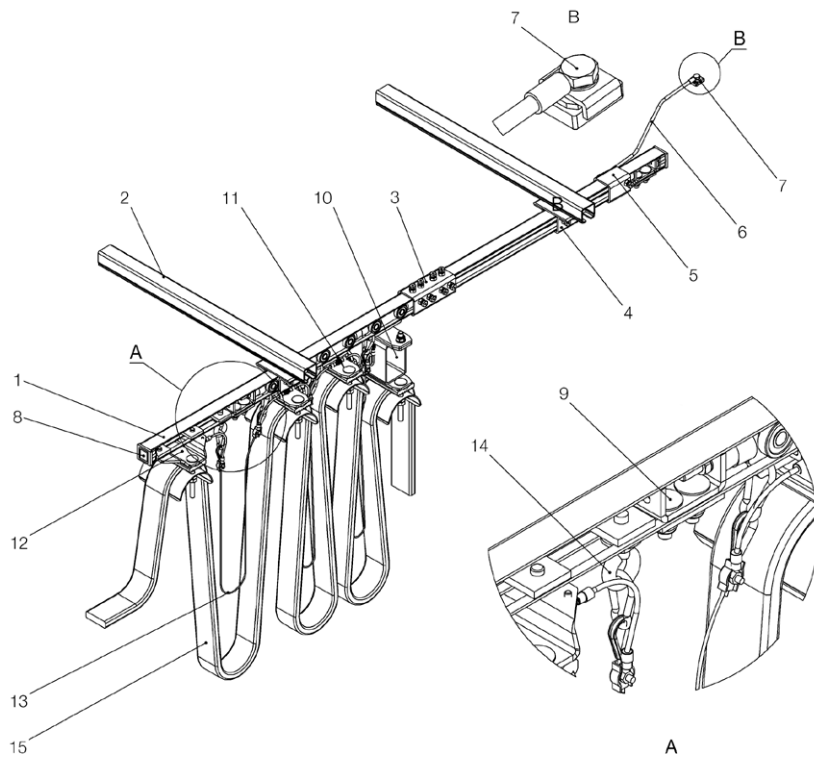

- 1 C-Rail
- 2 Support Arm
- 3 Track Coupler
- 4 Support Bracket
- 5 Ground Terminal Clamp
- 6 Protective Conductor
- 7 Protective Conductor Connection
- 8 End Cap
- 9 End Stop
- 10 Towing Trolley EX
- 11 Cable trolley EX
- 12 End Clamp EX
- 13 Tension Relief Rope/Potential Equalization
- 14 End Clamp (Eyelet)
- 15 Cable

Festoon System with Control Unit Trolley

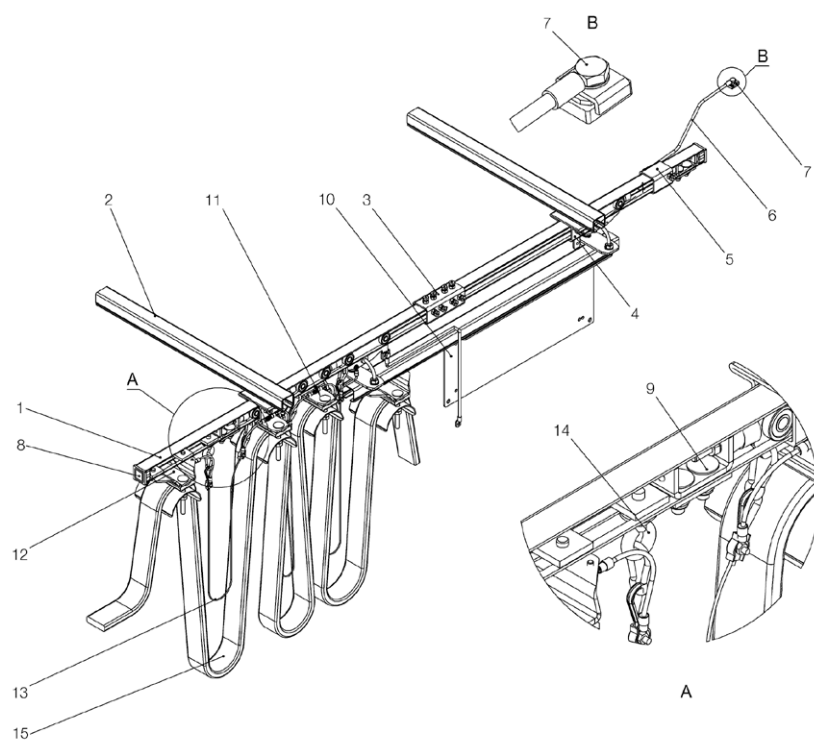

- 1 C-Rail
- 2 Support Arm
- 3 Track Coupler
- 4 Support Bracket
- 5 Ground Terminal Clamp
- 6 Protective Conductor
- 7 Protective Conductor Connection
- 8 End Cap
- 9 End Stop
- 10 Control Unit Trolley Upper Parts
- 11 Cable trolley EX
- 12 End Clamp EX
- 13 Tension Relief Rope/Potential Equalization
- 14 End Clamp (Eyelet)
- 15 Cable

ATEX Accessories Program 0240 for ATEX

Protective Conductor

- Part No.: 02-S215-0006
 • Cross section 10 mm²

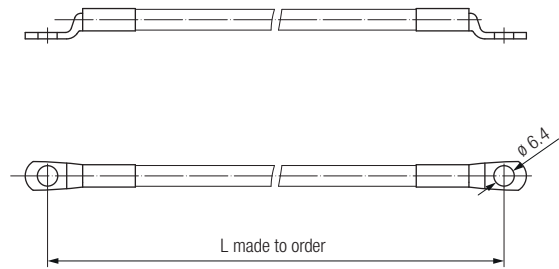

Protective Conductor Connection

- Part No.: 02-S215-0002
 • Material: galvanized steel

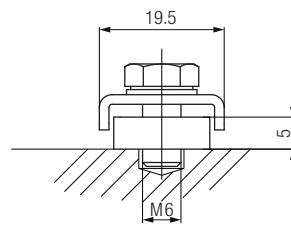

Tension Relief Rope/Potential Equalization

- Part No.: 020330-02EX#
 • Cross section: 2 mm
 • Material: galvanized steel

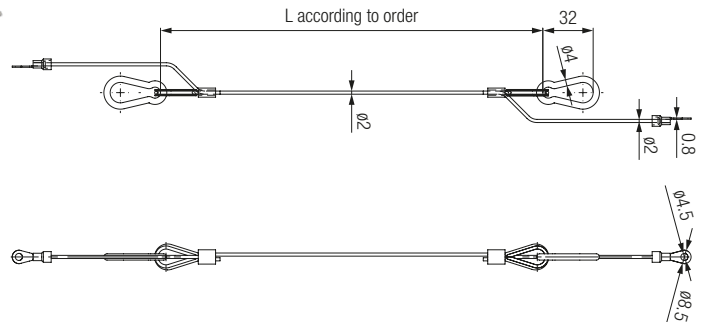

Ground Terminal Clamp

- Part No.: 02-E007-0002
 • Material: galvanized steel
 • Weight: 0.27 kg

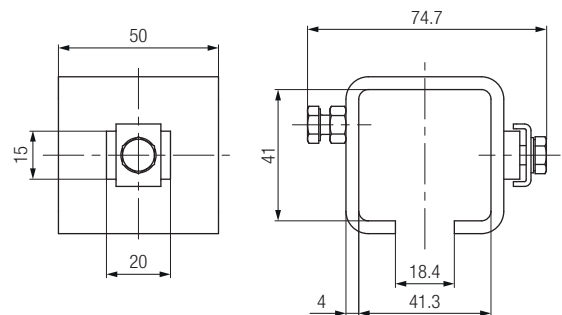

Rail Connector

- Part No.: 024105EX
 • Material: galvanized steel
 • Weight: 0,630 kg

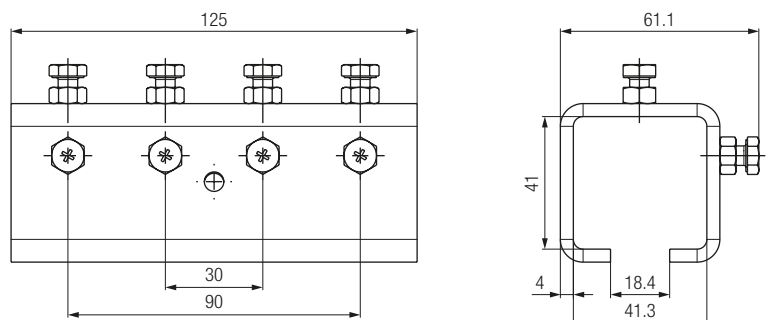
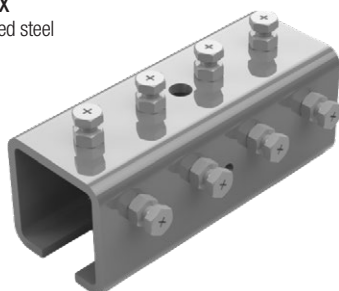

Cable Trolleys Program 0240 for ATEX

Cable Trolleys for Flat Cables Program 0240EX

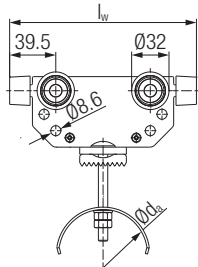

Cable Trolley

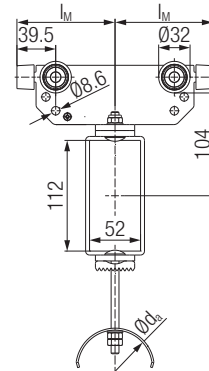
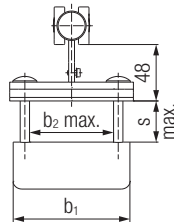

Towing Trolley

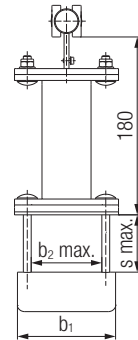

Technical details

- Trolley body and cable supports: galvanized steel
- Fasteners: galvanized steel
- Standard rollers: ball bearing, galvanized with ZZ-sealing
- Temperature range: -20°C to +50°C
- Max. carrying capacity: 32 kg

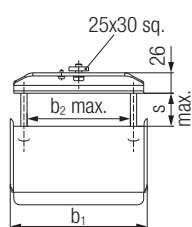

End Clamp

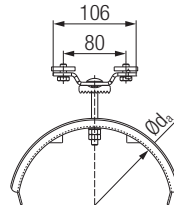

Cable Trolleys Part No.:	[kg]	Towing Trolleys Part No.:	[kg]	End Clamps Part No.:	[kg]	d _a	l _w	l _m	b ₁	b _{2 max}	s _{max}	
						[mm]	[mm]	[mm]	[mm]	[mm]	[mm]	
024210-125x100EX	0.85	024220-200x100EX	1.83	024230-100x042EX	0.70	80	125	100	100	72	20	
024210-125x160EX	1.09	024220-200x160EX	2.17	024230-160x042EX	0.95				160	132		
024210-160x100EX	0.93	024220-200x100EX	1.83	024230-100x042EX	0.70				100	72	38	
024210-160x160EX	1.17	024220-200x160EX	2.17	024230-160x042EX	0.95		160		132			
024210-200x100EX	1.05	024220-200x100EX	1.83	024230-100x062EX	0.70		200		100	72	58	
024210-200x160EX	1.29	024220-200x160EX	2.17	024230-160x062EX	0.95		160		132			
024212-160x100EX	1.05	024222-200x100EX	1.93	024232-100x042EX	0.80	125	160	100	100	72	15	
024212-160x160EX	1.38	024222-200x160EX	2.36	024232-160x042EX	1.13				160	132		
024212-200x100EX	1.15	024222-200x100EX	1.93	024232-100x042EX	0.80				200	100	72	35
024212-200x160EX	1.48	024222-200x160EX	2.36	024232-160x042EX	1.13		160		132			
024212-250x100EX	1.39	024222-250x100EX	2.16	024232-100x062EX	0.82		250		125	100	72	60
024212-250x160EX	1.72	024222-250x160EX	2.60	024232-160x062EX	1.15		160		132			
024213-200x100EX	1.30	024223-200x100EX	2.07	024233-100x042EX	1.00	160	200	100	100	72	18	
024213-200x160EX	1.72	024223-200x160EX	2.60	024233-160x042EX	1.40				175	132		
024213-250x100EX	1.40	024223-250x100EX	2.17	024233-100x042EX	1.00				250	125	100	72
024213-250x160EX	1.82	024223-250x160EX	2.70	024233-160x042EX	1.40		175		132			
024213-280x100EX	1.50	024223-280x100EX	2.27	024233-100x062EX	1.02		280		140	100	72	58
024213-280x160EX	1.92	024223-280x160EX	2.80	024233-160x062EX	1.42		175		132			
024214-250x100EX	1.50	024224-250x100EX	2.27	024234-100x042EX	1.10	200	250	125	115	72	22	
024214-250x160EX	2.07	024224-250x160EX	2.95	024234-160x042EX	1.65				175	132		
024214-280x100EX	1.60	024224-280x100EX	2.37	024234-100x042EX	1.10				280	140	115	72
024214-280x160EX	2.17	024224-280x160EX	3.05	024234-160x042EX	1.65		175		132			
024214-320x100EX	1.70	024224-320x100EX	2.47	024234-100x062EX	1.12		320		160	115	72	58
024214-320x160EX	2.27	024224-320x160EX	3.15	024234-160x062EX	1.67		175		132			

Cable Trolleys Program 0240 for ATEX

Cable Trolleys for Round Cables Program 0240EX

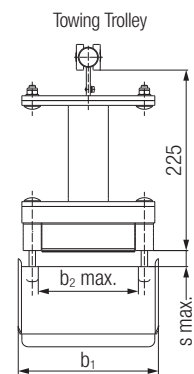
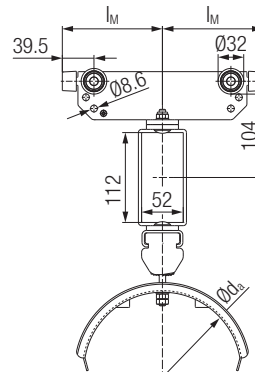
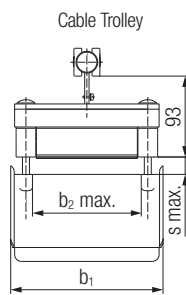
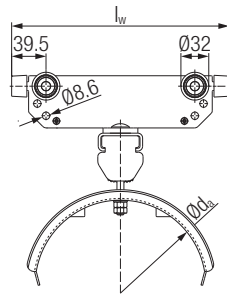

Technical details

- Trolley body and cable supports: galvanized steel
- Fasteners: galvanized steel
- Standard rollers: ball bearing, galvanized with ZZ-sealing
- Temperature range: -20°C to +50°C
- Max. carrying capacity: 32 kg

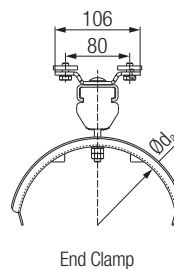
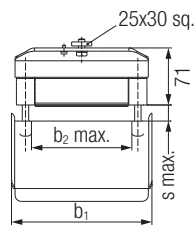

End Clamp

Cable Trolleys Part No.:	[kg]	Towing Trolleys Part No.:	[kg]	End Clamps Part No.:	[kg]	d _a [mm]	l _w [mm]	l _m [mm]	b ₁ [mm]	b _{2 max} [mm]	s _{max} [mm]
024474-250x100EX	1.70	024484-250x100EX	2.20	024494-100EX	1.45	200	250	125	115	65	20
024474-250x160EX	2.27	024484-250x160EX	3.07	024494-160EX	2.14				175	125	
024475-320x100EX	2.20	024485-320x100EX	2.90	024495-100EX	1.60	250	320	160	115	65	25
024475-320x160EX	2.72	024485-320x160EX	3.52	024495-160EX	2.36				175	125	
024477-400x160EX	3.52	024487-400x160EX	4.32	024497-160EX	2.69	320	400	200	175	125	32

Control Unit Trolley Program 0240 for ATEX

Control Unit Trolley Upper Parts Programm 0240EX

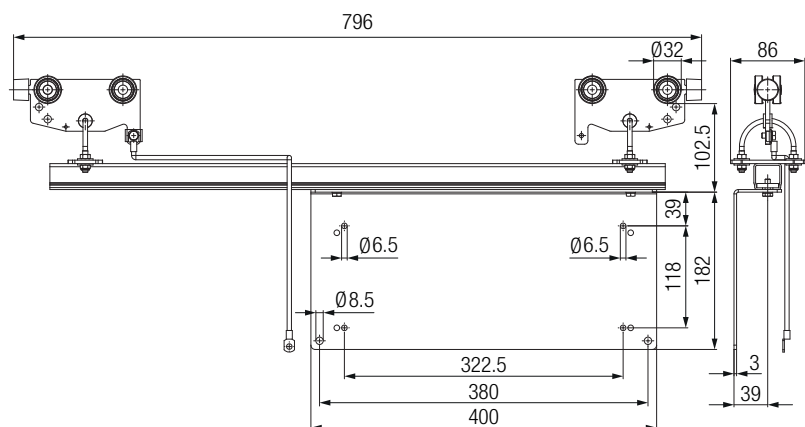
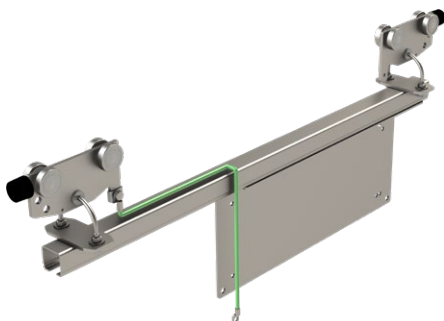

02-S023-0325

- Trolley body and cable supports: galvanized steel
- Fasteners: galvanized steel
- Standard rollers: ball bearing, galvanized with ZZ-sealing
- Temperature range: -20°C to +50°C
- Max. carrying capacity: 40 kg
- Weight: 4.5 kg

www.conductix.com

Conductix-Wampfler

has just one critical mission:

To provide you with energy and data transmission systems that will keep your operations up and running 24/7/365.

To contact your nearest sales office, please refer to:

www.conductix.contact

