

Conductor Rail System for Shuttles

MultiLine Program 0835



CONDUCTIX
wampfler

Table of Contents

General Information	5
System Advantages	5
Main Features at a Glance	6
Technical Data	7
Conductor Rail	8
End Segment (End Power Feed)	8
Rail Connector	9
Universal Rail Brackets	9
Current Collector Modules	10
Assembly Kit	11
Spare Parts Kit	11
System Layout	12
FAQ	13

Conductor Rail System for Shuttles

MultiLine 0835

General Information

The multi-pole, modular, compact conductor rail system **MultiLine 0835** is designed specifically for use in intralogistics; e.g. shuttle systems or transfer units. Its space-efficient dimensions and layout with an expandable number of poles (including protective earth) enables flexible use in similar applications, such as automated small-parts storage systems, longitudinal feeding units, or electric shearing stations in the packaging and paper industries.

Optimized handling, a limited number of parts, and an easy connecting method were the main goals for the design of this multi-pole small conductor rail system, significantly reducing the time needed for preparation and installation on-site.

Small conductor rails are mainly used when available installation room inside the track profile is constricted. In many cases the rails need to be installed without proper visibility at the installation site. The **MultiLine 0835** system is specifically designed to aid the installer in such situations, with details such as tactile markings, self-centering connectors, sturdy clip-on elements, and simple, compact installation appliances.



System Advantages

- Faster, easier installation due to the rigid rail profile and the need for half as many rail brackets as similar systems
- Fewer parts that reduce logistic and installation expenditures
- Predefined connections by using plug-in claw type fasteners
- Reduced installation work due to clip-on fastening and self-aligning connections
- Expandable system length and number of poles
- High rigidity through multipole structure and hollow-chamber profiles
- Available as 2 and 3 phase, as well as phase + PE (protective earth) versions

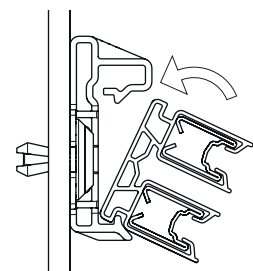

Clip-on bracket

Conductor Rail System for Shuttles MultiLine 0835

Main Features at a Glance

- **Material requirements (without Current Collectors):**

Only few single components are needed for a 2-pole aisle.

Example of a 2-pole aisle, length 65 m
(without Current Collectors and Cables):

Self-aligning
Connectors!

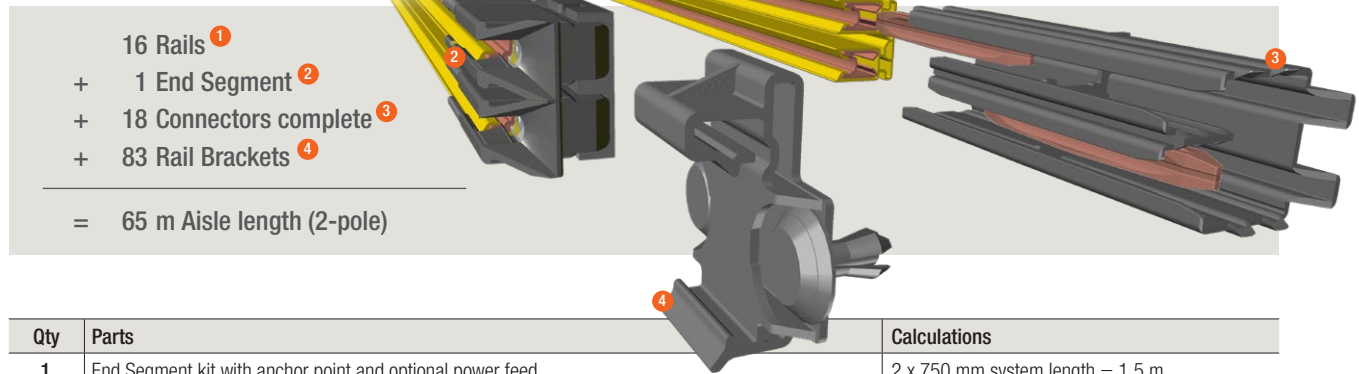

- 16 Rails ¹
 - + 1 End Segment ²
 - + 18 Connectors complete ³
 - + 83 Rail Brackets ⁴
-
- = 65 m Aisle length (2-pole)

Qty	Parts	Calculations
1	End Segment kit with anchor point and optional power feed	2 x 750 mm system length = 1.5 m
16	Rails @ 4000 mm to cover aisle length incl. 1 fitting part @ 3.5 m (pre-cut)	65 m - 1.5 m = 63.5 m / 4 m ≈ 16 pcs. 65 m - 1.5 m - (15 x 4 m) = 3.5 m
18	Connectors complete (2 x Connectors + 1 x Connector cap)	
83	Rail Brackets	65/0.8 + 2 ≈ 84 pcs. net.

Material not used in every aisle:

Qty	Parts
1	Spare parts pack
1	Assembly kit

- **Installation**

Installation can be completed in a few steps, mostly without any tools.
Each part is designed to ensure the correct mounting position primarily by feel, taking into account the low visibility and constricted installation space often prevalent in warehouse aisles.

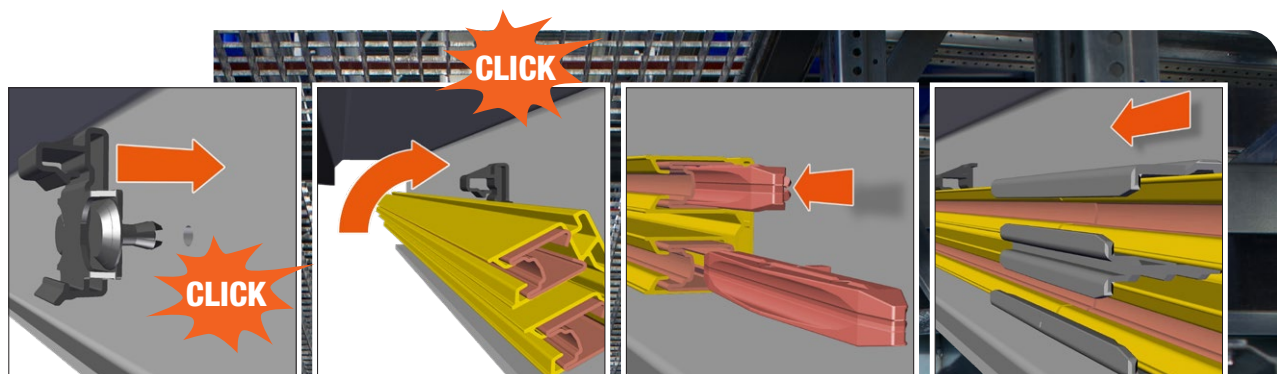

Your
installation –
our
responsibility!



Photo: KNAPP AG

Conductor Rail System for Shuttles

MultiLine 0835

Technical Data

System and application area	Multipole conductor rail for aisle power supply in shuttle systems, for AS/RS, and similar industrial applications
Installation position	Horizontal rail direction with current collectors engaged laterally (see illustration below)
Rated rail length	4000 mm +/- 2 mm at 20°C
Suspension spacing	Rated length 800 mm
System length	Maximum 100 m (for greater lengths, please inquire)
Travel speed	300 m/min
Rated voltage	500 V AC/DC
Current load	32 A (100% duty cycle)
Min. current and voltage	1 A and 24 V; at lower currents and voltages, the electrical contact is not optimal. We would be happy to advise you!
Protection class	IP 2X ¹⁾
Resistance at 35°C	0.000778 [Ω/m]
Impedance at 50 Hz/35°C	0.000803 [Ω/m]
Conductor cross section/material	25 mm ² (Cu-ETP)
Permitted ambient temperature	-15°C up to + 60°C
Chemical resistance	Our components are typically made of PVC, PPE, PC, PA, and PPT. The chemical resistance of these materials must be checked against the substances present on site. We would be happy to advise you on this.

¹⁾ Based on the fully assembled complete system. Current collectors comply with IP2X standard. However, forces greater than those specified in the standard may still result in contact with live parts. Please take this into account in your customer risk analysis.

Dimensions, weights, system grid	
Width	2-pole: 26 mm; 3-pole: 40 mm
Depth	83 mm with single collector heads 98 mm with dual collector heads
Weight	0,58 kg/m

Insulating cover (stabilized hard PVC; safety warning color (RAL 1018))	
Dielectric strength	22.4 kV/mm as defined by DIN 53481
Flammability	Meets requirements for insulating materials as defined by UL 94 V-0; flame-retardant and self-extinguishing as defined by (IEC) DIN EN 60895-11-10B3, 3 UL-Certificate: ELPX.E16232

Relevant standards	
DIN EN IEC 60664-1, VDE 0110-1:2022-07	Insulation coordination for equipment within low-voltage supply systems – Part 1: Principles, requirements and tests (IEC 60664-1:2020); German version EN IEC 60664-1:2020
DIN EN 60204-1, VDE 0113-1:2019-06	Safety of machinery – Electrical equipment of machines – Part 1: General requirements (IEC 60204 - 1:2016, modified); German version EN 60204-1:2018
DIN EN 60529, VDE 0470-1:2014-09	Degrees of protection provided by enclosures (IP code) (IEC 60529:1989 + A1:1999 + A2:2013); German version EN 60529:1991 + A1:2000 + A2:2013

Note: subject to technical change. We recommend consulting Conductix-Wampfler if the system is to be used in applications or conditions other than stated to ensure technical feasibility. Technical statements may restrict each other. In case of doubt we recommend consulting for feasibility.

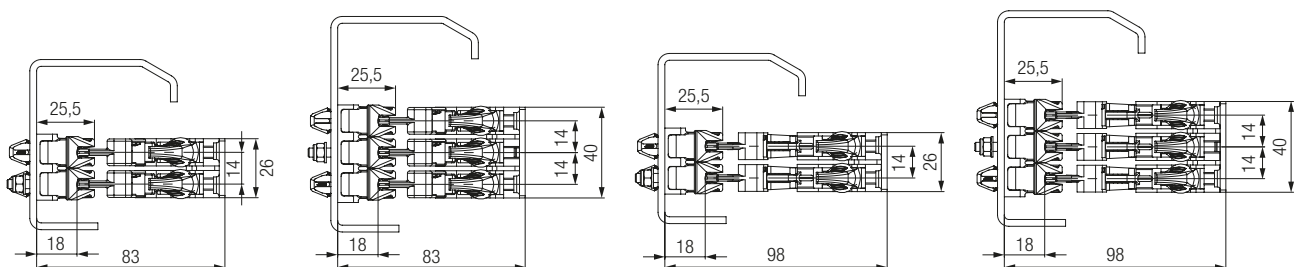

0835 2-pole with single
Collector heads (081507)

0835 3-pole with single
Collector heads (081507)

0835 2-pole with dual
Collector heads (081509)

0835 3-pole with dual
Collector heads (081509)

Conductor Rail System for Shuttles

MultiLine 0835

Conductor Rails

Standard rails (4 m length) can be carried easily by one person. Rails can be shortened on-site with a bow saw or jig saw.

- Rated length: 4000 mm
- Insulation: PVC
- Conductor material: Cu-ETP
- Cross section: 25 mm²

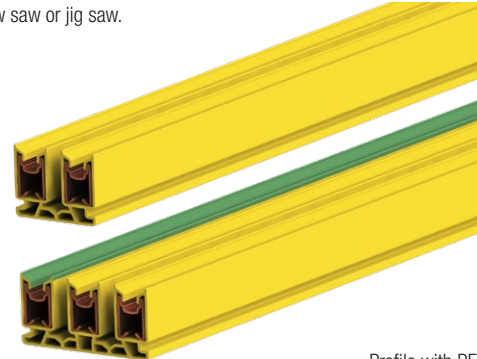
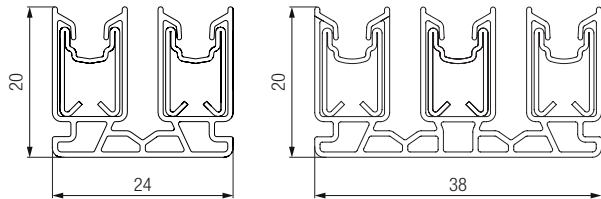

Profile with PE
(protective earth) conductor
(PE marked with a green stripe)

Part No.	Description	Conductor material	Number of poles	Weight [kg]
083516-4X21X11	Conductor rail 0835 Cu 2-pole PH	Copper	2 x PH	2,3
083516-4X21X12	Conductor rail 0835 Cu 2-pole PE	Copper	1 x PH, 1 x PE	2,3
083516-4x31x11	Conductor rail 0835 Cu 3-pole PH	Copper	3 x PH	3,6
083516-4x31x12	Conductor rail 0835 Cu 3-pole PE	Copper	2 x PH, 1 x PE	3,6

(SAP Config.-No. for shorter rails: 0835X-X#)

End Segment (End Power Feed)

Designed as closing and optional power feed for the conductor rails, an end segment (standard length 750 mm) is required on both ends of the rail system. The end segment with end cap link serves as an anchor point.

- Rated length: 2 x 750 mm
- Insulation: PVC
- Conductor material: copper
- with optional power feed incl. ring cable lug

Scope of delivery: 2 x end segment with optional power feed (cable lug), excl. cable

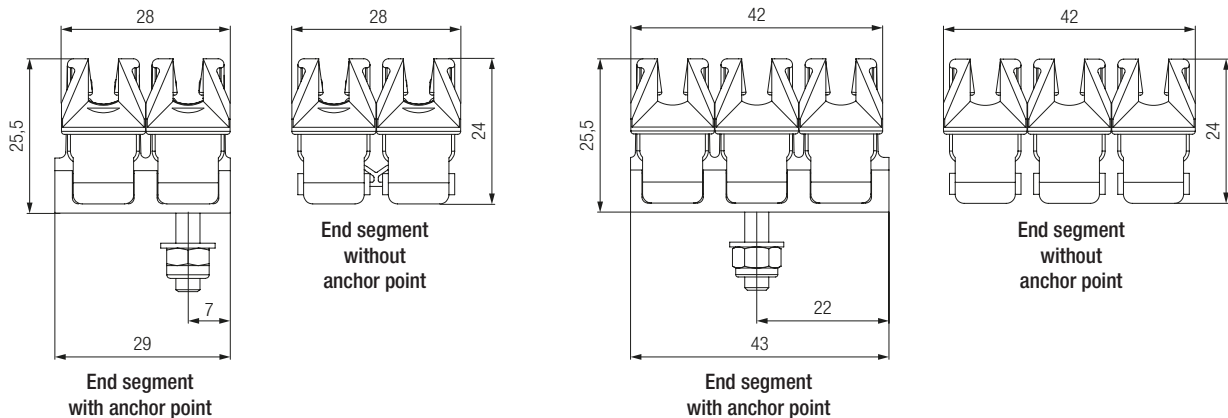

Part No.	Description	Connection	Scope of delivery	Number of poles	Weight [kg]
083553-260X611	End feed 0835 Cu 2P PH 6,0 mm ²	6,0 mm ²	fastened end + loose end	2 x PH	0,5
083553-260X612	End feed 0835 Cu 2P PE 6,0 mm ²	6,0 mm ²		1 x PH + 1 x PE	0,5
083553-360X611	End feed 0835 Cu 3P PH 6,0 mm ²	6,0 mm ²		3 x PH	1,4
083553-360X612	End feed 0835 Cu 3P PE 6,0 mm ²	6,0 mm ²		2 x PH + 1 x PE	1,4

Conductor Rail System for Shuttles

MultiLine 0835

Rail Connectors

Plug-in connectors for two conductor rails. Consisting of:

- two plug-in connectors for conductor rails
- one connector cap (with centering function)
- rated current: 32 A

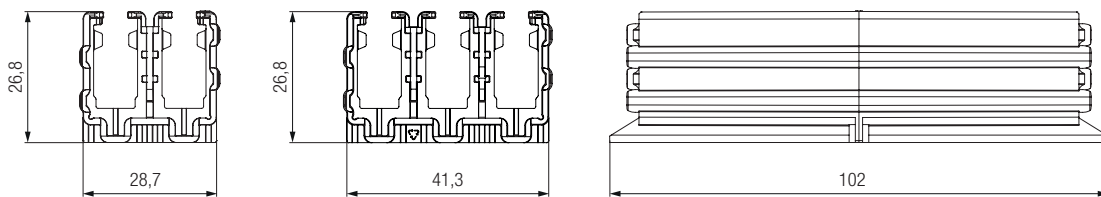
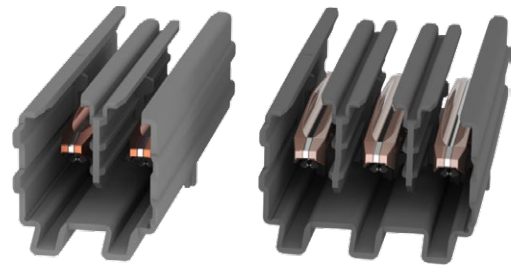

Part No.	Description	For rail material	Poles	Weight [kg]
083526-6	Connector 0835 2P PL Cu	Copper	2	0,05
083526-63	Connector 0835 3P PL Cu	Copper	3	0,06

Universal Rail Brackets

Rail brackets are used to attach the conductor rail to a customer-supplied substructure. Rail brackets with rivets can be used with a wide range of sheet metal thicknesses. Rail brackets with clip function are quicker and easier to install, but require more precise matching of sheet metal thicknesses.

Custom sheet metal thicknesses and holders are possible for large quantities. Clip rail holders can be arranged in the 14 mm grid of the current collectors.

Riveted rail holders cannot always be arranged in the 14 mm grid.

- Fastened by plastic expanding rivets, for sheet thicknesses from 2 to 7 mm
- Rated suspension spacing: 800 mm
- Minimum distance to connector cap: 150 mm

Delivery includes expanding rivets.

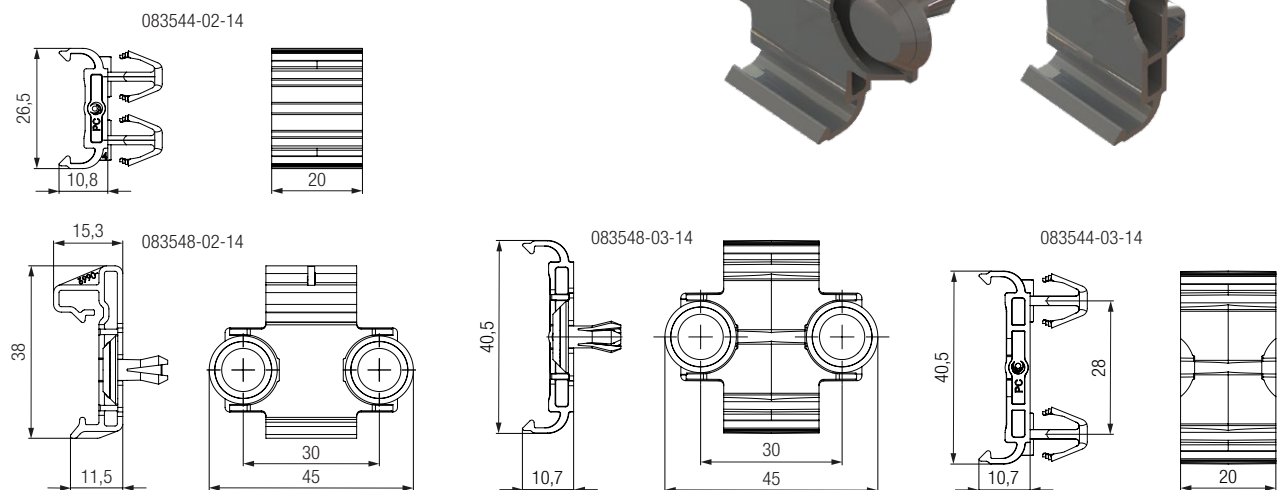
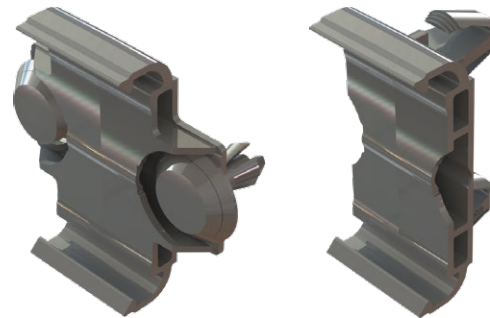

Part No.	Description	Type	Stackable	Number of poles	Weight [kg]
083548-02-14	Rail bracket 0835 2-pole	Rivet	no	2	0,006
083544-02-14	Rail bracket 0835 2-pole	Clip	yes	2	0,003
083548-03-14	Rail bracket 0835 3-pole	Rivet	yes	3	0,004
083544-03-14	Rail bracket 0835 3-pole	Clip	yes	3	0,003

Conductor Rail System for Shuttles

MultiLine 0835

Current Collector Modules

Individual current collectors are assembled together with base plates to form current collector modules. Current collectors and modules are available individually or as pre-assembled modules. The use of modules can be easier for new installations. Modules can be easily adapted to your requirements in terms of number of poles, type of current collector, and orientation. All current collectors from the 0815 program can also be used in the 0835 program. More information on 0815 current collectors can be found in the catalog: **Single-Pole Insulated Conductor Rail Program 0815**

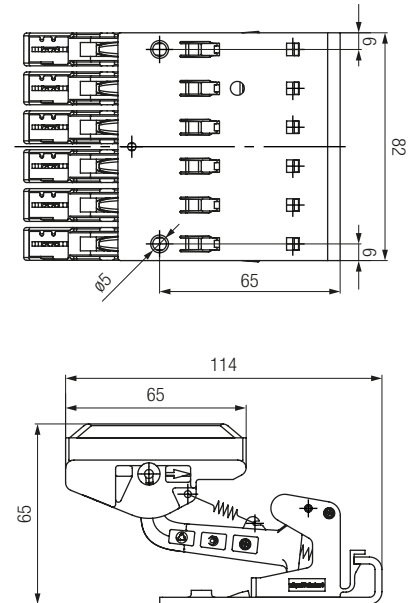
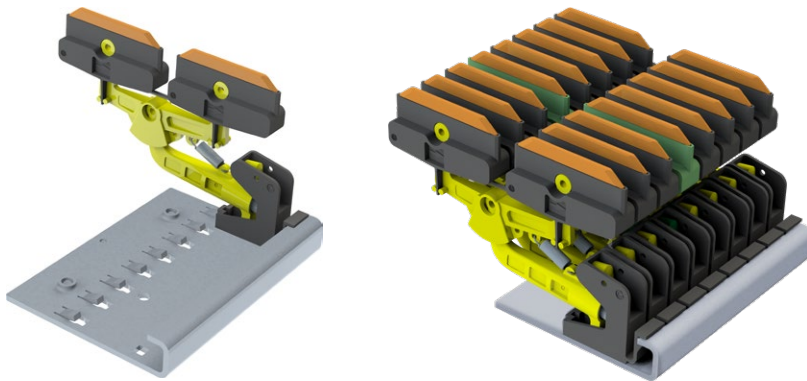

Part No.	Type	Electrical data	Mechanical data
081607-X#		16 A graphite	Max. stroke ± 10 mm Max. lateral offset ± 10 mm
081507-X#		35 A copper-graphite	Shared variant for reversing and towing operation
081508-X#		2 x 16 A graphite	Max. stroke ± 10 mm Max. lateral offset ± 10 mm
081509-X#		2 x 25 A graphite	One special variant each for reversing and towing operation

Conductor Rail System for Shuttles

MultiLine 0835

Assembly Kit

The stopper is clamped to the first profile, to join the rails together by using the mounting cap and a soft-head hammer.

Material: shock-resistant plastic

Contents:

- 1 x Stopper
- 1 x Mounting cap

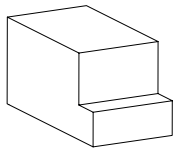

Stopper

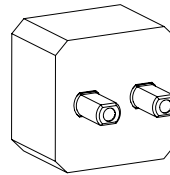
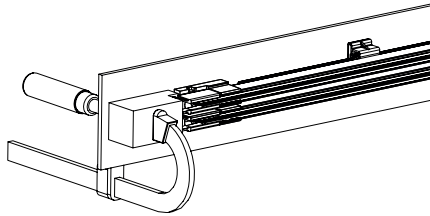

Mounting cap

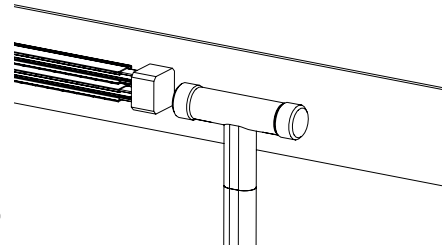

Part No.	Description	Weight [kg]
08-V015-0463	Assembly Kit 2-pole	0,8
08-V015-0534	Assembly Kit 3-pole	0,8

Spare Parts Kit

The pack includes all small parts to replace missing or worn parts, as well as one Assembly Kit (stopper and mounting cap).

Contents:

- 1 x End cap link
- 4 x End caps complete incl. clamping unit
- 4 x Crimp ring cable lugs 2.5 mm²
- 4 x Crimp ring cable lugs 6.0 mm²
- 2 x Connector caps
- 4 x Plug connectors to join copper rails
- 5 x Standard rail brackets
- 12 x Expanding rivets
- 1 x Assembly Kit



Part No.	Description	Weight [kg]
08-S089-0002	Spare Parts Kit 2-pole	0,8
08-S089-0009-002	Spare Parts Kit 3-pole	0,8

Current Collector Replacement and Spare Parts

See Catalog KAT0815: **Single-Pole Insulated Conductor Rail Program 0815**

Conductor Rail System for Shuttles

MultiLine 0835

System Layout

To allow for thermal expansion of the system, only one anchoring point may be installed at the start of the system.

The end segment with end cap base also serves as the anchoring point for the system.

081507 – Single Current Collector

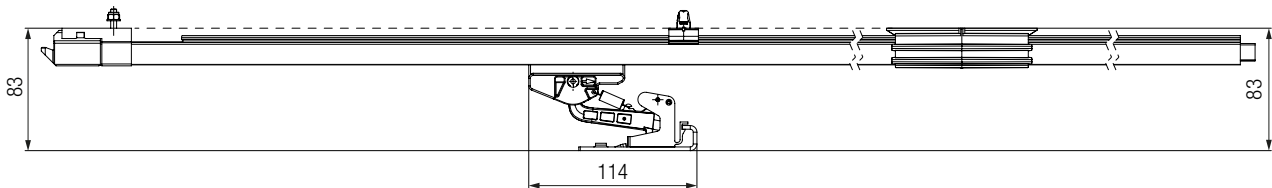

081509 – Dual Current Collector

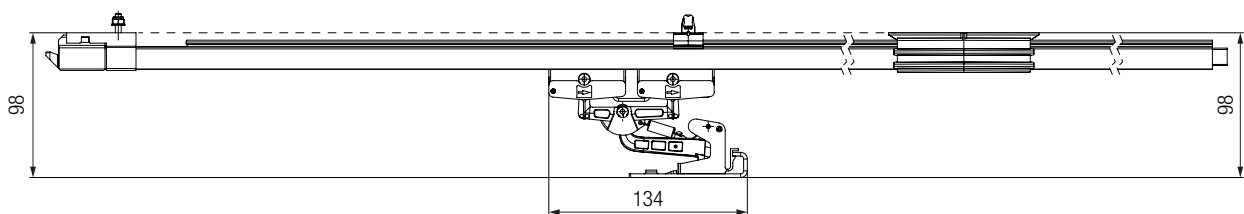

0835 2-pole

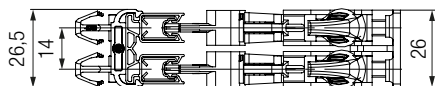

0835 3-pole

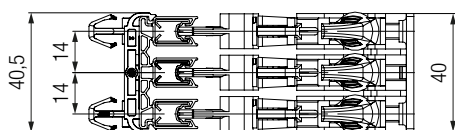

0835 5-pole (2- + 3-pole stackable)

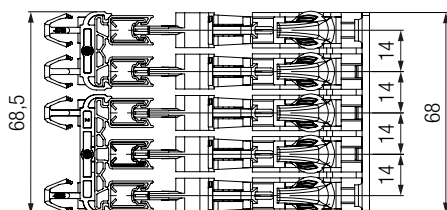

Conductor Rail System for Shuttles

MultiLine 0835 – FAQ

Is a vertical installation possible, e.g. on an automated small-parts storage system mast?

The system is designed and optimized for horizontal installation. Suitability in vertical installations, especially in regards to highly dynamic movements, depends on technical requirements and installation sites. Please contact us for possible approval and part modifications.

Are curved sections feasible?

The purposely rigid structure of the rails does not allow curved sections. If required, parts from a compatible product line can be combined with the 0835 system. Please contact us and provide a drawing of the intended layout.

Can the rails be easily replaced in case of damage?

If the system is precisely installed in a secure location within a shuttle application, mechanical or electrical damages to the rails are unlikely to occur. However, rails can be replaced after shutting off the system and following these steps:

Using a flat-blade screwdriver, unclip the rail from the brackets ahead and behind the place of repair, and cut off the damaged part with a bow saw or jig saw.

Deburr the rail. Pull down the insulating profile a few centimeters and cut off 5 mm of the insulation. Measure the fitting piece and cut accordingly. Reinstall the rail and connect, using new rail connectors.

What is the maximum amperage of the system?

The system is designed for a maximum continuous current of 32 A and thus meets the requirements of typical industrial applications. The conductor cross-sectional area of the conductor rail is significantly larger than would be required for 32 A alone. This oversized cross-sectional area may only be used for voltage drop calculations and is not permitted as a basis for determining rated current values.

Is it possible to configure a three-phase system?

A 400 V-system with three phase (PH) conductors and one protective earth (PE) conductor is feasible by combining two rail pairs (1 x 2-poles PH and 1 x 2-poles PH and PE). According to international standards the protective earth (PE) conductor is marked green and yellow to prevent confusion with phase (PH) conductors.

How much time can actually be saved during installation?

Time measurements taken during installations in shuttle applications and transfer units show that fewer installation parts (-65%) and ease of handling (due to the design of the parts) reduce distribution and installation times by 50% to 60% when compared to similar single-pole small-scale conductor rail systems.

Are there other benefits?

Fewer parts and pieces means easier purchasing logistics. Another benefit is the easy installation due to plug-in claw type fasteners. This technology allows for fast personnel training and ensures reproducible and continuous contact quality. Undetected mistakes made during installation are prevented, insofar as feasibly possible.

Is the MultiLine 0835 system compatible to the SingleFlexLine 0815 system?

Conductor material and geometry, as well as current collectors and basic dimensions have been adapted from the 0815 system. Upgrading from 0815 to 0835 is possible without exchanging any of the moving parts. With little modification, the systems can be form-fitted, or parts from the 0815 system can be integrated into the new 0835 system.

Your Applications – our Solutions

The solutions we deliver for your applications are based on your specific requirements. In many cases, a combination of several different Conductix-Wampfler systems can prove advantageous. You can count on Conductix-Wampfler for hands-on engineering support together with the optimum solution to safely meet your needs.

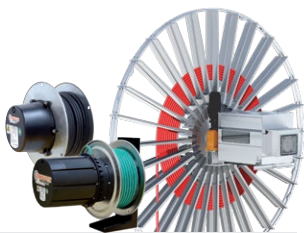

Cable and Hose Reels

Motor driven and spring driven reels by Conductix-Wampfler provide energy, data and media over a variety of distances, in all directions, fast and safe.



Festoon Systems

Conductix-Wampfler cable trolleys can be used in virtually every industrial application. They are reliable, robust and available in an enormous variety of dimensions and designs.

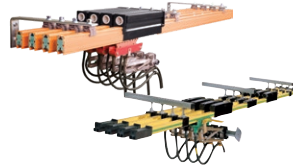

Conductor Rails

Available as enclosed or multiple unipole systems, Conductix-Wampfler conductor rails reliably move people and material.



Inductive Power Transfer

The no-contact system for transferring energy. For all tasks that depend on high speeds and absolute resistance to wear.



Non-insulated Conductor Rails

Robust, non-insulated aluminum conductor rails with stainless steel cap provide the ideal basis for power supply of people movers and transit networks.



Radio Remote Controls

Safety remote control solutions customized to meet our customer needs with modern ergonomic design.



Reels, Retractors and Balancers

Available for hoses and cables, as classical reels or high-precision positioning aids for tools, we offer a complete range of reels and spring balancers.



Jib Booms

Complete with tool transporters, reels or an entire media supply system – safety and flexibility are key to the completion of difficult tasks.

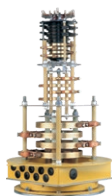

Slip Ring Assemblies

Whenever things are really “moving in circles”, the proven slip ring assemblies by Conductix-Wampfler ensure the flawless transfer of energy and data. Here, everything revolves around flexibility and reliability!



Mobile Control Systems

Mobile control solutions for your plant – whether straightforward or intricate. Control and communication systems from LJU have been tried and tested in the automotive industry for decades.



ProfiDAT®

This data transfer system is a compact slotted waveguide that can also be used as grounding rail (PE) at the same time.



Charging Solutions

Whether inductive or conductive, this bundle of products offers always the perfect solution for all industrial charging tasks including the matching battery with integrated battery management system.

www.conductix.com

Conductix-Wampfler

has just one critical mission:

To provide you with energy and data transmission systems that will keep your operations up and running 24/7/365.

To contact your nearest sales office, please refer to:

www.conductix.contact

