

**Insulated Conductor Rail System**

SinglePowerLine Program 0813

---

**Order Number:**

0813xx-...

---

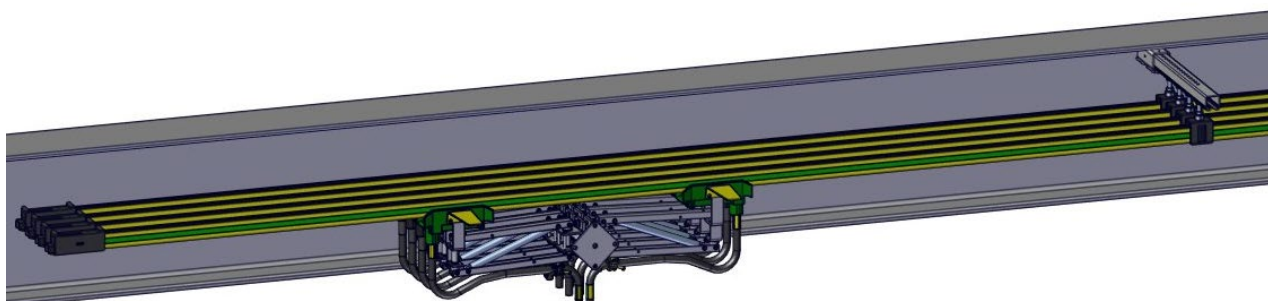

## Insulated Conductor Rail System

### SinglePowerLine Program 0813

---

## Contents

1	General Information .....	5
1.1	About this document .....	5
1.2	Limitation of liability .....	5
1.3	Copyright .....	6
1.4	Replacement parts .....	6
1.5	Material defects .....	6
1.6	Technical support .....	6
2	Safety Instructions .....	7
2.1	Explanation of symbols .....	7
2.2	Personnel requirements .....	8
2.2.1	Qualifications .....	8
2.2.2	Unauthorized persons .....	9
2.2.3	Training .....	9
2.3	Personal protective equipment .....	9
2.4	Intended use .....	10
2.5	Unintended use .....	11
2.6	Protective measures by the operator/user .....	12
2.7	5 Safety Rules for working on electrical systems .....	12
2.8	Special hazards .....	13
2.8.1	Electrical hazards and sources of danger .....	13
2.8.2	Mechanical hazards and sources of danger .....	14
2.8.3	Danger due to dust and vapors .....	15
2.8.4	Dangers related to the operational environment .....	16
2.9	Conduct in the event of accidents and malfunctions .....	17
3	Technical Data .....	18
3.1	Installation orientation .....	20
3.2	Tolerances .....	20
3.3	Unsuitable ambient conditions .....	21
4	Product Description and Functional Principles .....	22
4.1	Brief description .....	22
4.2	Interfaces .....	25
4.3	Description of the components .....	26
4.4	Accessories .....	33

## Insulated Conductor Rail System

### SinglePowerLine Program 0813

---

5	Transport, Packaging and Storage .....	37
5.1	Safety .....	37
5.2	Transport .....	38
5.3	Packaging .....	39
5.4	Storage of packaged parts .....	39
6	Installation .....	40
6.1	Safety .....	40
6.2	Provide additional protection against contact at the conductor rail end. ....	44
6.3	System arrangement .....	45
6.4	Installation of mechanical components .....	46
6.4.1	Required tools .....	46
6.4.2	Trim conductor rail .....	46
6.4.3	Install conductor rail system .....	49
6.4.3.1	Mount hanger clamps .....	50
6.4.3.2	Mount conductor rail .....	54
6.4.3.3	Connect rails .....	57
6.4.3.4	Mount line feed .....	61
6.4.3.5	Mount anchor clamp .....	65
6.4.3.6	Mount heating wire (optional) .....	67
6.4.3.7	Mount expansion unit .....	68
6.4.3.8	Mount air gap .....	70
6.4.3.9	Mount end caps .....	73
6.4.3.10	Mount pickup guide .....	76
6.4.4	Mount current collector .....	79
6.4.4.1	Current collector insertion from the side .....	83
6.4.4.2	Typical mounting errors .....	83
6.5	Electrical installation .....	84
6.5.1	Conductor Rail .....	84
6.5.2	Current Collector .....	84
6.6	Further Documents .....	84
7	Commissioning .....	85
7.1	Safety .....	85
7.2	Testing and initial commissioning .....	89
7.2.1	Test list .....	89
7.2.2	Initial commissioning of the conductor rail system .....	91
8	Operation .....	92
8.1	Safety .....	92



## Insulated Conductor Rail System

### SinglePowerLine Program 0813

---

8.2	Normal operation .....	95
8.3	Stopping the system .....	95
8.4	Continue operation .....	95
9	Maintenance and Service .....	96
9.1	Safety .....	96
9.2	Tools and materials .....	100
9.3	Replacement of sliding contacts .....	101
9.4	Maintenance plan .....	104
10	Troubleshooting .....	106
10.1	Safety .....	106
10.2	Fault correction table .....	109
11	Disassembly and Disposal .....	111
11.1	Safety .....	111
11.2	Disassembly .....	114
11.3	Disposal .....	114
12	Further Documents .....	115
12.1	Applicable documents .....	115
12.2	Air gap diagram .....	116
13	Index .....	117

## Insulated Conductor Rail System

### SinglePowerLine Program 0813

---

## 1 General Information

---

### 1.1 About this document

The information provided in this document is designed to enable the Conductor Rail System 0813 to be used safely and efficiently.

This document is a component of the Conductor Rail System 0813 and must be kept accessible to personnel and in close proximity to the Conductor Rail System 0813 at all times. Personnel must read this document carefully and understand it before starting any work. Compliance with all safety and handling instructions provided in this document is a basic requirement for safe working.

Local accident protection regulations and general safety guidelines for the area of use of the conductor rail system also apply.

The illustrations in this document are provided for basic understanding and may deviate from the actual implementation of the product.

In addition to these operating instructions, the instructions located in the appendices for the individual assembled components also apply.

### 1.2 Limitation of liability

All data and information in these operating instructions have been compiled while taking the valid standards and regulations as well as the state of the art and our many years of experience and knowledge into consideration.

The manufacturer accepts no liability for damage resulting from:

- Failure to comply with operating instructions
- Unintended use
- Use by untrained personnel
- Unauthorized modifications
- Technical changes
- Use of unauthorized replacement parts or accessories

The actual scope of delivery may differ from the explanations and descriptions provided here if the model in question is a special one, additional equipment has been ordered or due to recent technical changes.

The obligations agreed upon in the General Terms and Conditions of Business apply, as do the Delivery Conditions of the manufacturer and the legal regulations applicable at the time the contract was concluded.

All products are subject to technical modifications within the context of improvement of function and further development.

## Insulated Conductor Rail System

### SinglePowerLine Program 0813

---

#### 1.3 Copyright

This document is protected by copyright and is exclusively intended for internal use by customers.

Provision of the operating instructions to third parties, reproductions in any form – even in part – as well as the reuse and/or disclosure of their content are not permitted without the written approval of the manufacturer, except for the customer's internal use.

Breach or infringement will result in liability for damages. Our right to further claims remains unaffected.

#### 1.4 Replacement parts



**WARNING!**

##### **Incorrect replacement parts are a safety hazard!**

Incorrect or faulty replacement parts can impair safety and result in damage, malfunctions or complete failure.

→ Always use original replacement parts from the manufacturer!

Order replacement parts from your contracted dealer or directly from the manufacturer.

Contact information: See the last page of this document.

Replacement parts list: See Section 12.1 Applicable documents.

#### 1.5 Material defects

The terms governing material defects can be found in the General Terms and Conditions of Business.

#### 1.6 Technical support

Our Customer Support staff is available for technical support.

We are also always interested in new information, experiences and feedback from the field that can help us improve our products.

## Insulated Conductor Rail System

SinglePowerLine Program 0813

---

## 2 Safety Instructions

---

### 2.1 Explanation of symbols

Safety and hazard information is identified in these operating instructions using symbols. Safety instructions are introduced by signal words that indicate the degree of the hazard. Always observe safety and hazard instructions and work carefully to avoid accidents, bodily injury and damage to property!



**DANGER!**

... indicates an immediately hazardous situation, which, if not avoided, may result in death or serious injury.



**DANGER!**

... indicates an immediately hazardous situation due to electricity, which, if not avoided, may result in death or serious injury.



**WARNING!**

... indicates a possibly hazardous situation, which, if not avoided, may result in death or serious injury.



**WARNING!**

... indicates a possibly hazardous situation due to electricity, which, if not avoided, may result in death or serious injury.



**CAUTION!**

... indicates a possibly hazardous situation, which, if not avoided, may result in moderate or minor injury.



#### **Tips and recommendations:**

... refers to useful tips and recommendations as well as information for efficient and trouble-free operation.



**NOTE!**

... indicates actions that will help you prevent material damage.

## Insulated Conductor Rail System

### SinglePowerLine Program 0813

---

## 2.2 Personnel requirements

### 2.2.1 Qualifications



#### **Inadequately trained persons are at risk of injury!**

Unintended use can result in serious injury to persons and property.

→ All activities must only be performed by qualified personnel.

- Only persons who can be expected to perform their work reliably are acceptable personnel. People whose reactions are impaired by drugs, alcohol or medications, for example, are not authorized.
- When selecting personnel, all age- and occupation-specific regulations applicable at the place of use must be observed.

The following qualifications are specified in the operating instructions for certain fields of activity.

#### ■ **Specialist personnel**

Consists of persons capable of performing assigned tasks and independently identifying dangers and avoiding potential hazards based on their specialist training, knowledge and experience as well as their understanding of the applicable standards and regulations.

Personnel are considered qualified if they have successfully concluded training, for example, as electricians, master electricians, electrical engineers or electrical technicians. Personnel are also considered qualified who have been employed correspondingly for several years, have been educated in theory and practice during that time and whose knowledge and skills in the trade required have been tested.

The operator of the machine or system must document that the corresponding certification, or other documentation of qualification, is available or had been submitted previously.

The installation, maintenance and commissioning of electrical equipment may only be conducted by qualified personnel (electricians) according to local regulations. Work with higher installation positions typically requires additional qualifications and certificates for the use of lifting devices and protective equipment. On the part the manufacturer, professional and proper handling of components is required. It is recommended that the installation personnel be trained by the manufacturer or that accompaniment of the installation by specialist fitters/supervisors be scheduled.

#### ■ **Users**

Have been instructed in a training session by the operator with respect to the tasks assigned to them and the potential dangers arising from improper actions.

The operator of the machine or facility must document that the corresponding training has taken place.

#### ■ **Transport personnel**

Trained persons with appropriate training in transporting goods safely, who transport the material indoors and outdoors according to safety regulations, .

## Insulated Conductor Rail System

### SinglePowerLine Program 0813

---

#### 2.2.2 Unauthorized persons



**WARNING!**

**Danger due to unauthorized persons!**

Unauthorized persons who do not meet the requirements described here are not acquainted with the dangers in the working area.

- Keep unauthorized personnel away from the working area.
- In case of doubt, address such persons and direct them away from the working area.
- Stop working as long as unauthorized personnel are in the working area.

#### 2.2.3 Training

Before commissioning the equipment, personnel must be trained by the operator. Log the implementation of training for better traceability.

Example of instruction log:

Date	Name	Type of Training	Training given by	Signature
11/05/2009	John Doe	First safety training for personnel	Horst Müller	

### 2.3 Personal protective equipment

Always to be worn

Depending on local conditions and regulations, the personal protective equipment includes the following elements:



**Protective headgear**

For protection against falling or flying parts and materials.



**Protective gloves**

For the protection of hands against friction, scrapes, puncture or deeper wounds, as well as against contact with hot surfaces.



**Protective clothing**

Primarily for protection against entrapment by moving machine parts. Work clothing must be close fitting with a low resistance to tearing; it must have close-fitting sleeves and no protruding parts.



**Protective footwear**

For protection against heavy falling parts and slipping on slippery floors.

## Insulated Conductor Rail System

### SinglePowerLine Program 0813

---

To be worn for special tasks

When carrying out special work, special protective equipment is recommended. Separate reference to this is made in the individual sections.



#### Protective eyewear

For eye protection against harmful influences such as strong light, chemicals, dust, splinters or weather effects.



#### Hearing protection

For protection against loud noises and to prevent acoustic trauma.



#### Breathing mask (FFP3 — according to country-specific requirements)

For protection against materials, particles and organisms. In this case, for protection against the dust produced by the sliding contacts and the insulation of the conductor rail.

## 2.4 Intended use

The product is designed and built exclusively for the usage described here (intended use).



### WARNING!

#### Hazard due to unintended use!

Any application that deviates from or goes beyond the intended use of the product can result in hazardous situations.

- Strictly follow all information in these operating instructions.
- Refrain from unintended use of the system.
- Respect the instructions on unintended use in Section 2.5.

Claims of any kind due to damages from unintended use are excluded.

The operator bears sole liability for all damage that results from unintended use.

#### Intended use

The SinglePowerLine 0813 Conductor Rail System is an operating resource for the customer to set up an electrical power supply system indoors and in protected outdoor areas, in areas that are not accessible to the public. The conductor rail is an operating resource and thus has no actual operating mode since this is determined by the application. Risks are limited only to the failure of mechanical components (e.g., falling components) and the danger from electrical current.

The SinglePowerLine 0813 Conductor Rail System is used to supply electricity to mobile electrical consumers.

A typical use is, for example, in the area of bridge and process cranes.

Use other than in the application approved by the manufacturer must be examined by the system engineer as part of a risk assessment for the final product and is under the responsibility of the system engineer.

An extended approval by the manufacturer for the application is possible in certain cases and requires written approval after examination of the use case and ambient conditions.

## Insulated Conductor Rail System

### SinglePowerLine Program 0813

---

#### Compliance with these technical conditions is mandatory for the installation:

- The maximum travel speed is up to 600 m/min depending on the system (straight line without interruption).
- The conductor rail should preferably be installed horizontally with current collector insertion from below. With indoor areas, it is also possible to insert the current collector from the side (use current collector for lateral insertion).

#### Electrical engineering operating requirements

- The electrical system must be secured in compliance with the locally applicable regulations.

## 2.5 Unintended use

Claims of any kind due to damage incurred during use that deviates from the intended use described above ("use other than the intended use") are excluded. The operator bears sole liability for all damage that results from unintended use.

Unintended use particularly includes the following forms of use:

- Operation in unsuitable/unauthorized environmental conditions (see Section 3.3). The conductor rail system may **only** be operated under the environmental conditions described in the Section 3.
- Operation in an area accessible to the public.
- Operation within manual reach.
- Use in non-industrial applications.
- Overloading of the conductor rails by excessive current or voltage.
- Overloading of individual current collectors by excessive current or voltage.
- Use as a walking or climbing aid.
- Walking on the conductor rail.
- Use of unsuitable cleaning agents (e.g., silicone oils or aromatic compounds).
- Use of the system with accessories that are not approved and not authorized by the manufacturer.
- Use of the system by untrained personnel.

## Insulated Conductor Rail System

### SinglePowerLine Program 0813

---

#### 2.6 Protective measures by the operator/user

The product is used in the industrial sector. The operator of the conductor rail system is therefore subject to the legal obligations concerning workplace safety. In addition to the safety instructions in these operating instructions, all safety, accident protection and environmental regulations applicable to the use of the conductor rail system must also be observed. This particularly applies to the following:

- Work on electrical components of the system may only be conducted when in a **de-energized state**.
- The manufacturer/system engineer who installs the electrical equipment from Conductix-Wampller must inform their self about the applicable occupational safety regulations and determine additional hazards in a risk assessment that result from the special working conditions at the place of use of the product. They must implement these in the form of operating instructions for the operation of the conductor rail system.
- During the entire time the conductor rail system is in use, the operator must check that these operating instructions still correspond to the current state of regulations and adapt them as necessary.
- The operator must clearly manage and define responsibilities for installation, operation, troubleshooting and maintenance.
- The operator must ensure that all employees involved with the conductor rail system have read and understood these operating instructions. In addition, the operator must also train the personnel at regular intervals and inform them of hazards.
- The operator must provide personnel with all required protective equipment (work clothes, safety shoes, hearing protection, protective gloves, safety helmet, goggles, breathing mask).
- The operator must keep the keys for the switching cabinets in a safe place. "Safe" means that only explicitly authorized personnel may have access to the keys. The keys may only be issued to technical personnel as described in Section 2.2.1.

The operator is furthermore responsible for ensuring that the product is always in perfect working order. The following therefore applies:

- The operator must ensure that the service intervals described in these operating instructions are observed.
- The operator must get all safety systems regularly inspected for functionality and completeness. If possible, this inspection should be conducted once a year, but at least as often as required under the applicable national regulations.
- If the conductor rail system or the system has been modified, the safety systems must be inspected again and adapted to the changed conditions in such a way that the conductor rail system or the system is safe again.

#### 2.7 5 Safety Rules for working on electrical systems



##### **De-energize the entire system and secure against unintentional switching on!**

Work on electrical systems must only be conducted when they are in a de-energized state. The 5 Safety Rules (see DIN VDE 0105-100/EN 50110-1).

Observe before starting the work:

- Disconnect the system from power using the main switch.
- Secure the main switch against being turned back on.
- Verify the absence of a voltage through measuring.
- Ground and short-circuit parts of the system on which work will be done.
- Cover or block off neighboring parts that are still energized.

→ Only electricians or personnel trained in electrical work may disconnect power or approve reconnection of power after the work is conducted in the disconnected state!

## Insulated Conductor Rail System

### SinglePowerLine Program 0813

---

## 2.8 Special hazards

The following section lists residual risks determined on the basis of a risk assessment.

- Follow the safety instructions and the warnings in these operating instructions in order to reduce health hazards and avoid dangerous situations.

### 2.8.1 Electrical hazards and sources of danger



**DANGER!**



#### **Risk of death due to electrical shock!**

Contact with energized components can lead to death or severe injury due to electrical shock. There is also a risk of injury due a shock reaction, falling or being thrown across the room as a result of an electrical shock.

Work on the following components is dangerous:

- Main power supply
- Parts under voltage: Line feed, cables, connections, conductor rail, connectors, current collectors, products and connections within switching cabinets, control systems, etc.
- Parts that have come under voltage due to a fault

#### **Before working on the parts listed above:**

- **Disconnect** the conductor rail system from the **power supply and secure it against switching on again** according to the 5 safety rules (see Section 2.7)

#### **During work:**

- Use insulated tools

#### **Before switching on:**

- Every time before the product or system is started, test the insulation resistance according to locally applicable technical standards, directives and legal regulations.
- Conduct locally required electrical tests

#### **Maintain electrical safety:**

- Regularly test and maintain electrical equipment.
- If dangerous defects are identified, immediately take measures to correct the defects. Inform the system operator immediately
- If it is not possible to correct the dangerous defect, block off/secure the area involved or turn the operating resource off and secure it against switching on again. Inform the system operator immediately!
- Immediately secure loose cables and replace damaged cables.
  - Always replace blown fuses with fuses of the same rating.

## Insulated Conductor Rail System

### SinglePowerLine Program 0813

---



**DANGER!**

#### **Fire hazard due to overload or sparking!**

Fire hazards occur due to overloaded cables, electrical arcs, short circuits or sparking. Sparking can occur with poorly serviced, contaminated conductor rails or if the installation does not comply with the required tolerances.

- Permissible current values must be observed.
- Comply with tolerances during installation.
- Design and dimension systems according to the permissible system load capacity and provide appropriate protection devices.
- Do not store combustible and/or easily ignited materials near conductor rails.
- Check, service and clean conductor rails regularly and as prescribed. See Section 8 and 9

#### **2.8.2 Mechanical hazards and sources of danger**



**DANGER!**

#### **Risk of injury due to ensnarement or impact!**

An ensnarement and/or impact with moving conductor rails (slip ring) or current collectors connected to the machine and other components must be prevented.

- Cordon off the work area.
- Use caution when working in the vicinity of the danger zone, in particular if protective devices (covers, enclosures, control devices, etc.) have been removed or deactivated.
- Use caution when working in the vicinity of the danger zone, particularly below the conductor rail.
- Wear personal protective equipment!



**WARNING!**

#### **Secure components against falling!**

Possible falling components must be determined in the customer analysis as part of the operator's risk and hazard analysis.

- The operator must take appropriate measures.

## Insulated Conductor Rail System

### SinglePowerLine Program 0813

---

#### 2.8.3 Danger due to dust and vapors



**WARNING!**



#### **Danger of sensitization, mucous membrane irritation and respiratory disease due to dust!**

Abrasions from the sliding contact carbon brushes collect in the conductor rails and the guideway. This dust is very fine and is a health hazard. Frequent handling can result in sensitization. Persons who frequently spend longer periods in a heavily used system without protective equipment must reckon with the **following** consequences:

- Irritations of the mucous membranes
- Respiratory diseases
- Cancer

These consequences must also be expected if accumulations of dust are handled without proper care (e.g., removal of dust using compressed air).

- In workplaces with long-term exposure and heavily trafficked plants, take effective measures to protect employees from the dust.
- During all work on the conductor rail system in which collected dust can be stirred up, wear personal protective equipment. In particular, wear personal protective equipment when cleaning the system:
  - Protective eyewear
  - Protective dust mask Class FFP3 (observe local regulations)
  - Protective gloves
  - Disposable coveralls

- For soiled and dusty conductor rails, clean them as prescribed before starting work. There are special instructions for this task; see Section 9.
- During cleaning operations, protect the surrounding area, for example by covering or removing stored materials and blocking off areas in which dust could fall down on persons.
- **Do not blow out dust with compressed air**, but rather vacuum it away. The vacuum must be equipped with a Class HEPA H fine filter
- Do not eat, drink or smoke during work!

#### **Poisonous vapors/gases during fire!**

The standard insulation material contains PVC. Poisonous vapors/gases can be produced during a fire in the facility.

- System manufacturers/operators must take this into account when planning the entire system and provide appropriate protective measures against fire.
- Halogen-free materials can be used on request.
- The building must be evacuated immediately.
- Notify the fire department.



**DANGER!**

## Insulated Conductor Rail System

### SinglePowerLine Program 0813

---

#### 2.8.4 Dangers related to the operational environment

The following factors can give rise to hazards if the conductor rail is installed in this operational environment:

- Dust
- Gases
- Fog
- Chemical substances
- Moisture
- Liquids
- Radiation
- Temperature
- Contaminants

The **most important measure** to protect against these hazards is to only install the conductor rail system in locations where **appropriate operating conditions** prevail (see Section 3.3).

The system must be designed and operated according to the prevailing ambient conditions.

#### **Risk of materials and components being damaged and losing functionality due to environmental influences!!**

Environmental influences (dust/gases, chemical substances, liquids, radiation, etc.) can damage the materials and components, particularly the plastic parts, which can then pose dangers (breakage, loss of function). For example, hanger clamps can break, and the conductor rail system can fall down.

- The chemical environmental influences on the components, particularly on the plastic parts, must be checked for each application. The chemical resistance depends on the temperature, exposure time, concentration and interactions and must be checked in each individual case
- For applications in the vicinity of chemical operations, galvanizing plants, electroplating plants, compost works, warehouses and locations for the processing of aromatic compounds, benzene and other substances from these material groups, we ask that you please contact us for the purpose of alternative installation positions and materials and possible necessary additional components.

The chemical resistance of plastic parts is critical when in contact with oils, greases or various cleaning agents.

Major temperature variations can cause large expansions in the conductor rail system, particularly for long systems. For example, hanger clamps can break, and the conductor rail system can fall down.

The conductor rail cannot adapt to changes in temperature if the design and/or installation is incorrect. Component damage can arise through the occurring forces, which can result in the conductor rail falling down.

**The system must be designed and operated according to the prevailing ambient conditions within the framework of the permissible operating conditions!**



**DANGER!**

#### **Fire hazard due to sparking!**

Highly flammable dusts, substances or gases in the vicinity of the conductor rail can be ignited by sparks! These substances must not be present in the vicinity of the conductor rail.



**DANGER!**

## Insulated Conductor Rail System

### SinglePowerLine Program 0813

---



**DANGER!**

#### **Hazard due to energy storage!**

If consumers with energy storage are supplied by the conductor rail, these must be disconnected from the conductor rail or the energy storage system must be discharged according to the manufacturer's specifications before starting work and the system must be checked for the absence of voltage.

## 2.9 Conduct in the event of accidents and malfunctions

### **Measures in the event of accidents:**

- Shut down the system and secure it against unauthorized, unintentional and/or erroneous reactivation.
- Secure the danger zone.
- Remove persons from the danger zone.
- Initiate first aid measures.
- Alert the rescue services.
- Inform responsible parties at the operating site.
- Make access available to rescue vehicles.

### **Actions to take in the event of malfunctions:**

- Shut down the system and secure it against unauthorized, unintentional and/or erroneous reactivation.
- Secure the work area against entry.
- Consult qualified personnel when analyzing the fault.
- Check for disconnection from power.
- Remove the product and replace it with a new product.
- Determine the cause of the fault and repair the product.

## Insulated Conductor Rail System

### SinglePowerLine Program 0813

### 3 Technical Data

System	Insulated conductor rail system for use in supplying energy to crane systems, the construction of larger slip ring arrangements, transfer carriages, cable tracks or similar moving consumers mounted in non-publicly accessible areas, out of hands' reach in indoor areas and weather-protected outdoor areas (IP2x).
Installation orientation	Current collector insertion from below; current collector insertion from the side is also possible in indoor areas.
Rail length	5000 mm (nominal size at 20° C/tolerance ± 3 mm)
Phase offset	80 mm (standard)/70 mm (reduced with offset current collector arrangement)
Suspension interval	2.5 m/typically 2.4 to 2.5 m
Maximum system length	Unlimited
Travel speed	Maximum 600 m/min (straight line without interruption)
Permitted ambient temperature *	-15°C to +55°C (85°C in heat-resistant version/PPE-SB) [Lower temperatures on request. At lower temperatures, flexible lines should be used.]
Maximum temperature difference	Δ 40 K
Maximum conductor temperature	+85°C (115°C for heat-resistant version/PPE-SB, briefly 125°C)
Protection type	With current collector insertion from below: IP23 (DIN EN 60529, VDE 0470-1); with current collector insertion from the side: IP21
Storage temperature	-30°C to +40°C (store in a dry place dry, avoid condensation)
Minimum installation temperature	-10°C (recommended installation temperature: Above 0°C)
Local approvals	UL/CSA/EAC
Max. Air humidity at +40° C	85% rel. H/non-condensing
Altitude above sea level	≤ 2000 m
Travel direction	Forward and backward (reversing)

\* Note: At temperatures below -10°C, the mechanical load must be limited through physically limiting the breaking strength.

Conductor bar material	Aluminum with stainless steel contact surface			CopperECO			Copper		
	081313	081314	081319	08131C	08131D	08131I	081315	081316	081317
Type	3	4							
Current load [A] at 100% DC and 35°C (rated value)	500	800	1000	500	800	1000	500	800	1250
at 60% DC	510	810	1050	510	810	1050	520	880	1400
Rated voltage [V]	690 (UL 600 V) - min. 24 V/1 A (minimum load)								
Ohmic resistance at +35°C [Ω/1000 m]	0.097	0.074	0.051	0.097	0.074	0.051	0.104	0.057	0.033
+ 20°C [Ω/1000 m]	0.092	0.071	0.049	0.092	0.071	0.049	0.097	0.054	0.031
Impedance at +20°C [Ω/1000 m]	0.157	0.144	0.137	0.157	0.144	0.137	0.161	0.136	0.127
Impedance at +20°C [Ω/1000 m]	0.152	0.140	0.134	0.152	0.140	0.134	0.156	0.134	0.126

## Insulated Conductor Rail System

### SinglePowerLine Program 0813

---



**NOTE!**

**Current collector capacity:**

The current collector capacity is defined by the connected cable as well as sliding contacts used and is typically lower (see KAT0813-0002)! Ambient temperatures and operating modes result in reduced current collector capacity (e.g., operating at a standstill, operating at elevated temperatures).

Chemical resistance	
Insulating material	PVC: Good general chemical resistance PPE: Average chemical resistance, critical when in direct contact with oils, not suitable for outdoor use in direct sunlight.
Installation material	PC, PA, PBT: Good general chemical resistance, partly limited
Conductor bar material	Aluminum with stainless steel contact surface CopperECO Copper

Information regarding resistances are general notes and depend on the temperature, exposure time, concentration and interactions and must be verified in individual cases. Before usage in critical environmental conditions such as chemical operations, galvanizing plants, compost works and warehouses and locations with high concentrations of aromatic compounds, benzene and other substances from these material groups, we ask that you please contact us for the purpose of alternative installation positions and materials and possibly necessary additional components.

Insulating profile	
Material	Stabilized rigid PVC (standard material) and PPE-SB (heat-resistant version for indoor applications)
Flammability	Compliant with requirements for insulating materials according to UL94 V-1; flame-retardant and self-extinguishing (IEC60695-11-10); PPE + SB halogen free

Note: Under certain framework conditions, individual data is only valid to a limited extent.

## Insulated Conductor Rail System

### SinglePowerLine Program 0813

#### 3.1 Installation orientation



**WARNING!**

**Danger due to increased wear or damage!**

- Align the current collector with its central axis exactly on the central axis of the conductor rail
- The mean distance between the towing arm and the contact surface must be precisely complied with.



**WARNING!**

**Loss of contact or increased heating!**

Hazard due to loss of contact or increased heating if the current collector is operated outside the permissible installation position.

#### 3.2 Tolerances

The conductor rail must be installed within the following tolerances. Conductix-Wampfler does not accept any responsibility for the conductor rail's correct functioning if these tolerances are not observed. In such a case, Conductix-Wampfler does not accept any liability for problems that arise if the conductor rail system is not functioning correctly.

Conductor rails	X: $\pm 5$ mm
Current collector*	X: $\pm 100$ mm; Y: $\pm 40$ mm
Pressure with which the current collector contacts the rail	28 N (with double current collector: 2x28 N)

\*Depending on the current collector type

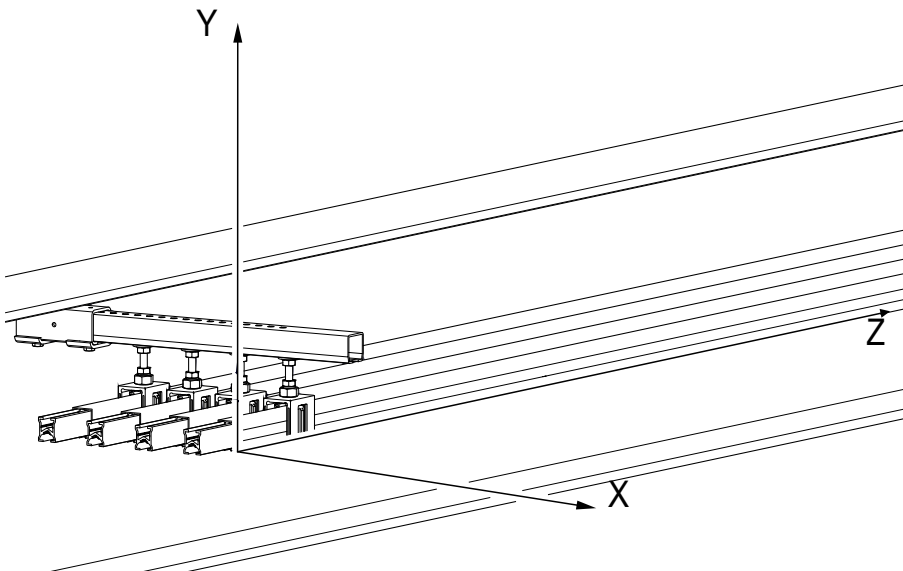

Fig. 1: Conductor bar 0813 coordinate system

## Insulated Conductor Rail System

### SinglePowerLine Program 0813

---

#### 3.3 Unsuitable ambient conditions

The conductor rail must **not be installed** and **not be operated** under these environmental conditions (see also Section 2.5 , Section 2.8.4 and Section 3):

- Operation at excessively high or excessively low temperatures (Standard: < -10°C, > 55°C, different ambient temperatures on request).
- In environments containing chemical substances or gases that can potentially permanently damage the conductor rail's materials (corrosion) or drastically impact on the insulation.
- In ambient air that contains solvent vapors or aromatic compounds.
- In ambient air that contains flammable or explosive gases or dusts.
- In flammable or explosive materials in the vicinity, particularly below the conductor rail.
- In dusty environments.
- Outdoors with free weathering.
- In environments with relative humidity of more than 85%.
- In close proximity to splashing water.
- In environments that require a higher protection class than IP 2X.



#### **WARNING!**

##### **Faults due to incorrect operating conditions!**

If the operating conditions change or are no longer within the specified range, the conductor rails can malfunction due to short circuits, premature aging and damage to electrical and mechanical components.

- The conductor rail must be disconnected from the power if the operating conditions are no longer within the permissible range described above.
- The conductor rail must be disconnected from the power if it gets wet or is soiled. Dry or clean according to regulations (observe WV0800-0001).
- Take the relevant measures to restore suitable operating conditions.

## Insulated Conductor Rail System

### SinglePowerLine Program 0813

---

## 4 Product Description and Functional Principles

---

### 4.1 Brief description

Single-pole insulated conductor rails consist of individual conductor rails firmly fixed on a guideway. One or more current collectors fastened to one or more mobile consumers engage with the conductor rails with their current collector heads. The mobile consumers move along the guideway in a linear, track-guided manner. The current collector follows the movement of the mobile consumer and compensates for guideway deviations between the mobile consumer and the conductor rails (horizontally and vertically).

The electrical energy is transmitted into the conductor rail through line feeds and then fed to the current collector. The current collector head of the current collector is pressed against the conductor rail with a continuous contact pressure. The electrical energy is transferred to the current collector head through the contact point and to the mobile consumer through a connecting cable on the current collector.

The SinglePowerLine 0813 Conductor Rail System is a modular conductor rail system for customer installation of an electrical power supply for moving, rail-guided parts or ring arrangements. Any number of poles can be combined in conductor rail systems.

The conductor bar material is available as aluminum with a stainless-steel strip, CopperECO and copper.

The connection to the power supply network is made via line feed connectors with a connection capability on the connector. Expansion units are available to compensate for temperature-related linear expansion. Air gaps can be used for the galvanic isolation of sections.

Examples of applications are:

- Crane systems
- Container stacking, steel mills or STS cranes
- People Movers

**Insulated Conductor Rail System**

SinglePowerLine Program 0813

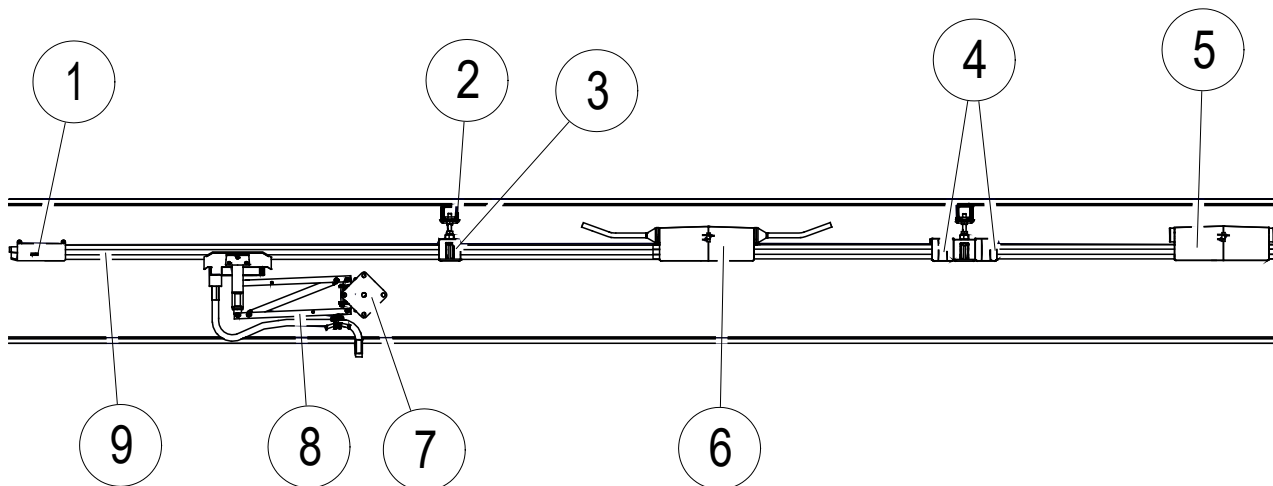

Fig. 2: System overview 0813

Pos.	Name
1	End cap
2	Support arm
3	Hanger clamp
4	Anchor clamps
5	Connector
6	Line feed connector
7	Towing arm
8	Single current collector
9	Conductor rail

**Examples of possible additional modules:**

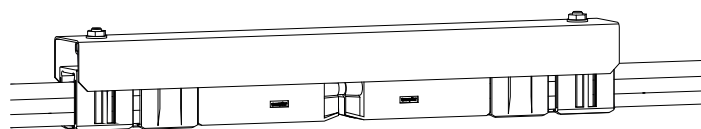

Fig. 3: Air gap 0813

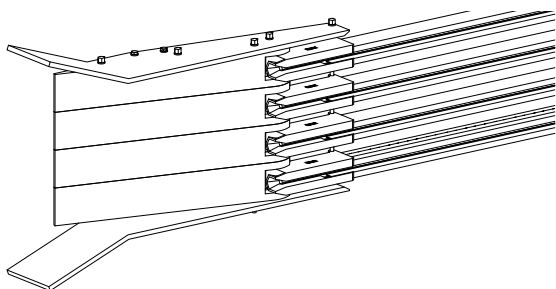

Fig. 4: Pickup guide 0813

## Insulated Conductor Rail System

### SinglePowerLine Program 0813

The rails are straight or curved. A distinction is made between horizontal and vertical rail arrangements

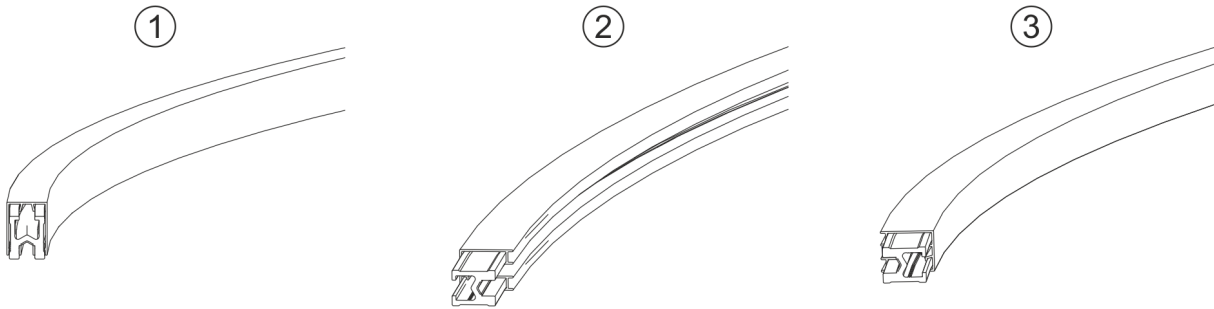

Fig. 5: Horizontal bend/inner and outer bend (horizontal arrangement)

Pos.	Name
1	Horizontal bend
2	Inner bend
3	Outer bend



Use the QR code ("click" or "scan") to see our animation **System Overview 0813**

## Insulated Conductor Rail System

### SinglePowerLine Program 0813

---

#### 4.2 Interfaces



All details are in the catalog KAT0813-0002 and, when applicable, in the system-specific layout.

##### **Mechanical interfaces:**

- The current collector must be fastened to the mobile consumer of the machine. The manufacturer/operator of the machine/system must comply with the required installation clearances and tolerances throughout the entire guideway. The fastenings are typically secured by screws.
- The hanger clamp must be attached to the support arms or the support structure of the machine. The manufacturer/operator of the machine/system must take into account the required suspension intervals, the fastening positions and the loads. The fastenings are typically secured by screws.

##### **Electrical interfaces:**

- The current collector head is connected to the electrical system of the mobile consumer via a flexible connecting cable. The connecting cable can be supplied in the scope of delivery. The system manufacturer/operator of the machine/system must observe the required conductor cross sections and when applicable, the design of the cable and ensure that it is installed flexibly and free of directional forces. The electrical design and integration into the overall electrical network are the responsibility of the facility manufacturer/operator. The connections are made using screw terminals.
- The conductor rail is fed with electrical energy from the network or from the machine/system via the line feed. A single-core cable is connected in the line feed. It is attached using cable lugs and screw connections. The connecting cables are not included in the scope of delivery. The electrical design and integration into the overall electrical network are the responsibility of the facility manufacturer/operator.

## Insulated Conductor Rail System

### SinglePowerLine Program 0813

---

#### 4.3 Description of the components

The SinglePowerLine 0813 Conductor Rail System consists of:

- Conductor rails
- Hanger clamps (interface to the machine of the system manufacturers/operator)
- Connectors
- Line feed connectors (interface to the machine of the system manufacturers/operator)
- Anchor clamps
- End caps/overrun caps for conductor rails
- Air gaps
- Expansion units
- Pickup guides
- Current collectors (interface to the machine of the system manufacturers/operator)
- Accessories (clamp arms, support arm brackets, clamping brackets, towing arms)

The conductor rails are fastened to a straight, smooth surface provided by the customer using hanger clamps. The conductor rails are electrically and mechanically coupled using connectors. The conductor rail is supplied with electrical energy through line feeds that mobile consumers can continuously tap using current collectors.

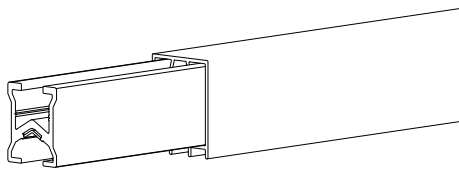

Fig. 6: Aluminum with a stainless-steel strip

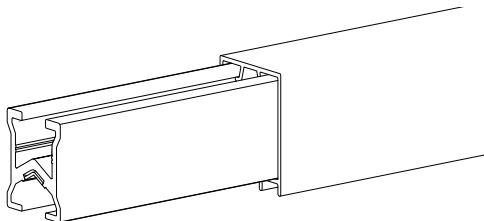

Fig. 7: CopperECO

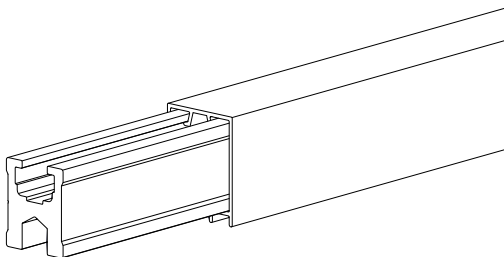

Fig. 8: Copper

#### ■ Conductor rail 08131 \*\*\*

Conductor rails with PVC insulating profile as PH and PE in nominal lengths of 5000 mm. The halogen-free PPE+SB is used for higher ambient temperatures.

PE rails are green/yellow. Phase rails are yellow. The conductor material of the conductor bars can be aluminum with a stainless-steel strip, CopperECO or copper. There are different rated currents from 500 to 1250 A.

PH = Phase conductor

PE = Protective conductor

## Insulated Conductor Rail System

### SinglePowerLine Program 0813

---

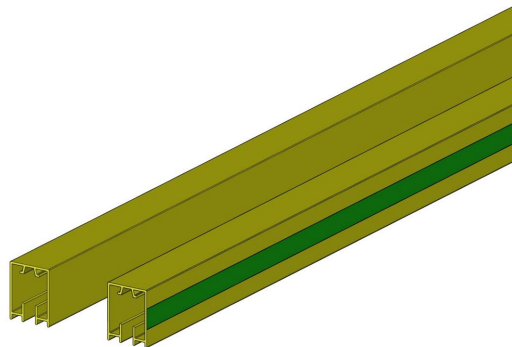

Fig. 9: PH insulating profile (yellow) and PE insulating profile (with green stripes)

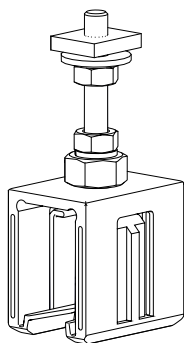

Fig. 10: Hanger clamp 0813 without insulator (square)

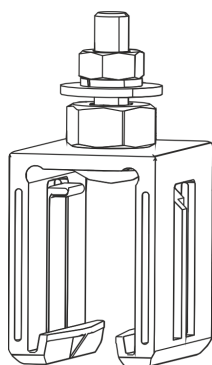

Fig. 11: Hanger clamp 0813 without insulator (hexagon)

#### ■ Hanger clamp 08134 \*\*\*

Hanger clamps for supporting the conductor rail. The hanger clamps are designed for mounting on a support arm or C-rail. The hanger clamps are available with hexagon nuts or square nuts.

Hanger clamps with insulators are used for indoor applications with high levels of contamination and outdoor applications with a rated voltage of up to 1000 V. They may only be used with current collector insertion from below.

## Insulated Conductor Rail System

### SinglePowerLine Program 0813

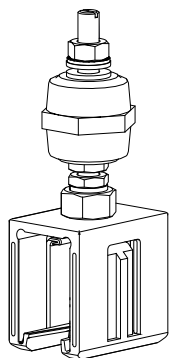

Fig. 12: Hanger clamp 0813 with insulator

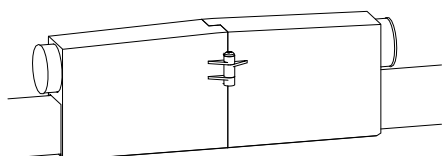

Fig. 13: Connector 0813

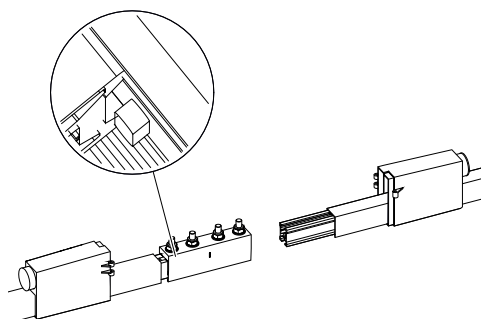

Fig. 14: Conductor rail at the connector stopper (aluminum-stainless steel/CopperECO)

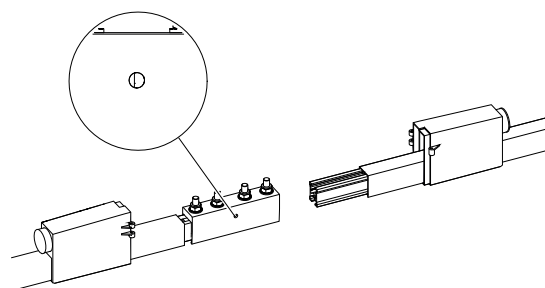

Fig. 15: The conductor rail end is in the connector's inspection window (copper)

#### ■ Connector 081321-\*\*\*

The conductor rail connections are made with compact screw connectors.

Depending on the conductor material of the conductor bar, the connectors have either a stopper (aluminum with stainless steel strip and CopperECO) or an inspection window (copper) to be able to check the functionally necessary gap of 2 to max. 3 mm at the rail ends.

There are two insulating cap halves that are screwed together with two screws for protection against contact.

**Note/Tip:** Aluminum-stainless steel and CopperECO conductor rails use the identical connector. A mixed installation of these two types of conductor rail is permitted.

## Insulated Conductor Rail System

### SinglePowerLine Program 0813

---

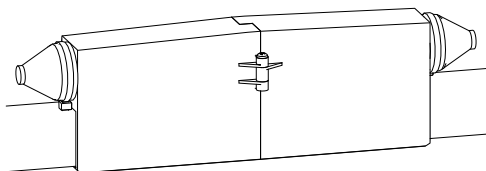

Fig. 16: Line feed 0813 (shown with insulating caps)

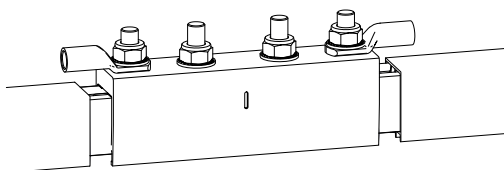

Fig. 17: Feed-in point with tubular cable lug (shown without insulating caps)

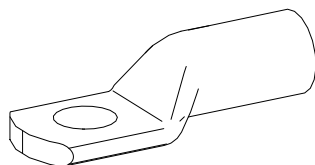

Fig. 18: Tubular cable lug 0813

#### ■ Line feed connector 081351-\*

The line feed takes place via line feed connectors. These are used instead of normal connectors. The electrical connection is made via spacer bolts and tubular cable lugs.

The connecting cable and the tubular cable lug are not included in the scope of delivery.

There are two insulating cap halves that are screwed together with two screws for protection against contact.

#### ■ Tubular cable lug 080054-\*\*

The electrical connection to the line feed connector is made via the tubular cable lug.

## Insulated Conductor Rail System

### SinglePowerLine Program 0813

---

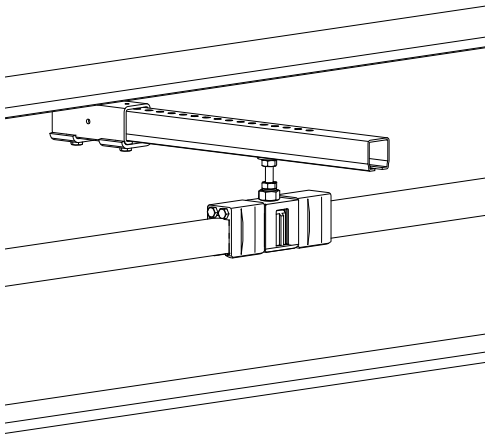

Fig. 19: Built-in anchor clamps

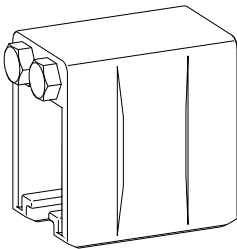

Fig. 20: Anchor clamp 0813

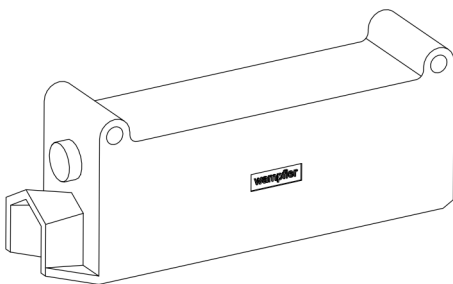

Fig. 21: End cap 081174

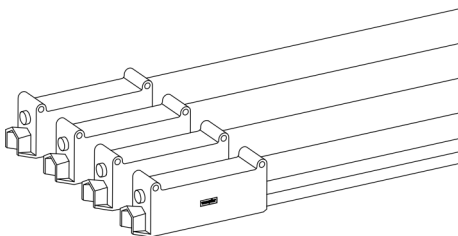

Fig. 22: End cap 0813 with conductor rails

#### ■ Anchor clamp 081331-2\*

By using two anchor clamps that are mounted around a hanger clamp, the conductor rail is fixed at one point (fixed point) and can be freely expanded from this point. The fixed point is typically attached near the line feed. If several fixed points are projected, for example, with transfers or curves (natural fixed point), the route between the fixed points is decoupled using expansion units. Attachment of the anchor clamp occurs through a clamping cone on the insulating profile.

#### ■ End cap 081371-\*\*

The end cap is used as a termination and as protection against contact with a free rail end. The caps are fixed to the conductor rail using clamping screws.

## Insulated Conductor Rail System

### SinglePowerLine Program 0813

---

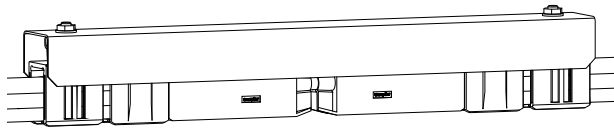

Fig. 23: Air gap 0813

#### ■ Air gap 08119\*-\*\*

Air gaps are used for galvanic isolation of sections that can be fed in and disconnected from the power separately, e.g., for maintenance lines. For each isolation point, 2 air gaps are installed at a suitable distance to avoid voltage leak across the current collector.

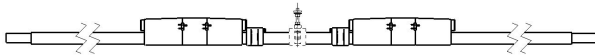

Fig. 24: Expansion unit 0813

#### ■ Expansion unit 081362-5X21XX

To compensate for temperature-related changes in length for systems > 200 m or sections of the route that are integrated between two fixed points, such as pickup guides at both ends of the section, expansion units are required to accommodate the change in length. The expansion unit has two expansion points, each of which can accommodate a maximum 45 mm expansion. The expansion units are delivered pre-assembled on a conductor rail (5000 mm). The middle section of the expansion unit must be supported with a hanger clamp (not included in the scope of delivery) on the customer's support structure/substructure.

The use of a double current collector is recommended when using expansion units.

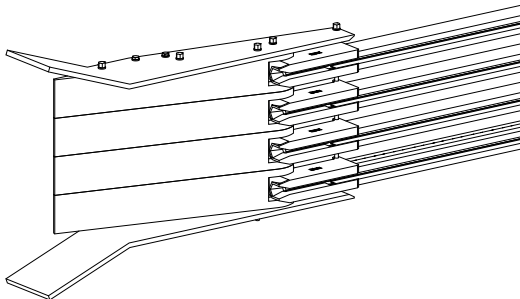

Fig. 25: Pickup guide 0813

#### ■ Pickup guide 08138\*\*\*

For areas in which it is necessary to travel in and out of the conductor rail system, pickup guides are used in conjunction with the current collectors intended for the purpose. It should be noted that the maximum speed for the pickup guides is 80 m/min, and pickup guides are classified as wear parts. The installation tolerances must be observed. Simultaneous offsets with the maximum tolerances in the x- and y-directions are not permitted.



**DANGER!**

#### **Hazard due to exposed current collectors!**

The user must ensure that while the current collectors are between transfer pickup guides, they are de-energized or protected against accidental contact.

## Insulated Conductor Rail System

### SinglePowerLine Program 0813

---

#### Current Collector

A current collector is a sliding electrical connection between the conductor rail and the mobile consumer. Redundancy for the PE current collector must always be included (min. 1 x double current collector).

When using inverters, there must also be redundancy for the phase current collectors (protection against shutdown due to loss of phase voltage in the case of transient loss of contact).

The current collector central axis must be mounted exactly on the central axis of the conductor rail. The installation dimension between the towing arm and the contact surface must be strictly maintained.

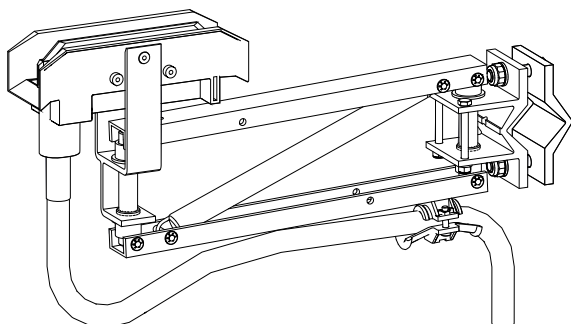

Fig. 26: Current collector

#### ■ Current collector 08130\*\*\*\*

Contact pressure: 28 N

Lateral deflection:  $\pm 100$  mm

Working stroke in insertion direction:  $\pm 40$  mm

Installation dimension between towing arm and contact surface: 125 mm

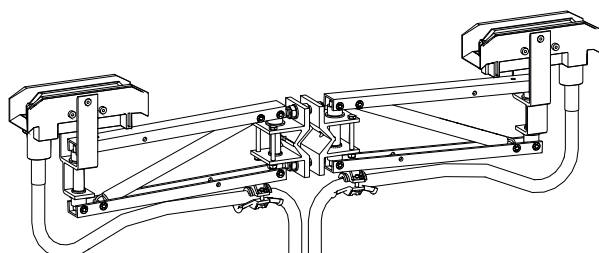

Fig. 27: Double current collector

#### ■ Double current collector 08130\*\*\*

Contact pressure: 2 x 28 N

Lateral deflection:  $\pm 100$  mm

Working stroke in insertion direction:  $\pm 40$  mm

Installation dimension between towing arm and contact surface: 125 mm

The spacer for insertion from the side must always be mounted on the underside of the current collector. See Section 6.4.4

Depending on each application and function, different types of current collectors are used:

- Current collector 250 A
- Double current collector 500 A
- Current collectors for special requirements, e.g., higher speeds
- Suitable or unsuitable for guide travel
- Insertion from below or from the side

#### Sliding contact

- The sliding contact is protected by a plastic insulation, so that no part under voltage can be reached in the event of accidental contact with the operational current collector.
- When replacing the sliding contact, it is not necessary to disassemble the sliding contact insulation since it is designed as a plug contact (no screw connection). Sliding contact delivery includes plastic insulation.

## Insulated Conductor Rail System

### SinglePowerLine Program 0813

---

#### 4.4 Accessories

The following accessories are specific special components and can also be ordered from Conductix-Wampfler (see KAT0813-0002):

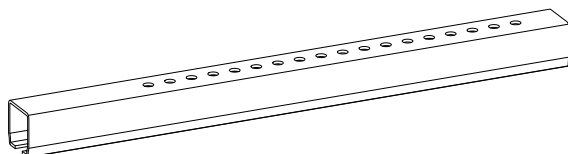

Fig. 28: Support arm (Sendzimir (hot dip) galvanized steel)

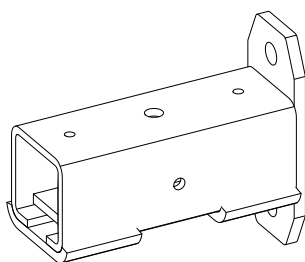

Fig. 29: Bracket for screwing on with 2-hole connection plate (steel, galvanized)

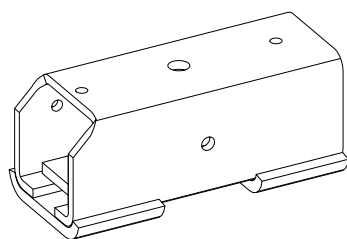

Fig. 30: Support arm bracket (Bracket: steel, blank; Small parts: steel, galvanized)

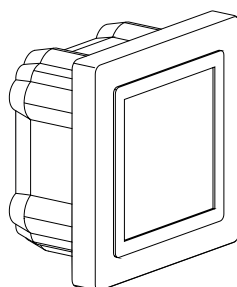

Fig. 31: End cap

■ **Support arm (0201860\*\*\*) and support arm bracket (020282/020286)**

A support arm can be used for attachment to the customer's support structure (substructure). The support arm is attached to the customer's support structure (substructure) using brackets. The brackets are available with and without a connection plate.

■ **End cap (020662-\*\*) for support arm (02018X-\*\*\*\*)**

The cap is used to close the support arm.

## Insulated Conductor Rail System

### SinglePowerLine Program 0813

---

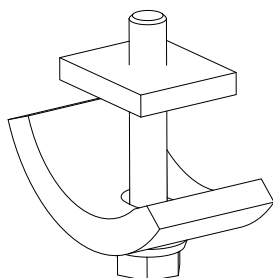

Fig. 32: Clamping brackets, clamping thickness 4-20 mm (galvanized steel or V4A)

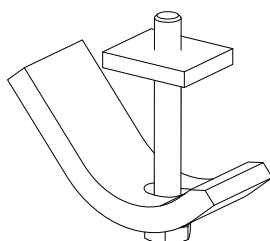

Fig. 33: Clamping brackets, clamping thickness 18-36 mm (galvanized steel or V4A)

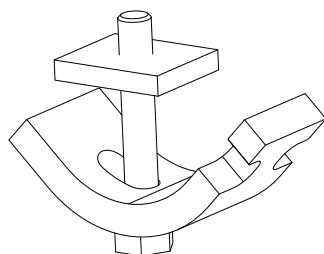

Fig. 34: Clamping brackets, anti-twist, clamping thickness 6-25 mm (galvanized steel)

■ **Clamping brackets (020180\*\*\*\*/020181-08)**

Clamping brackets can also be used, for example, to attach a support arm to the customer's support structure (substructure) without drilling or welding. There are different variants to cover clamping thicknesses from 6 mm to 36 mm.

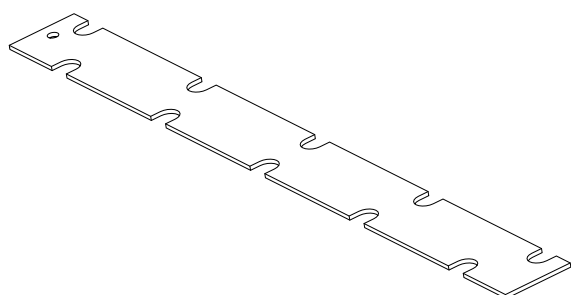

Fig. 35: Mounting comb

■ **Mounting comb (081046\*) for hanger clamp**

The mounting comb can be used to make it easier to set up the hanger clamp spacing (80 mm standard or 70 mm reduced) when mounting the support arm.

## Insulated Conductor Rail System

### SinglePowerLine Program 0813

---

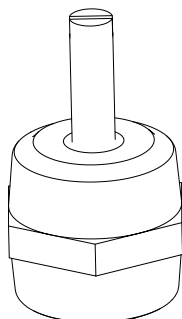

Fig. 36: Insulator

■ **Insulator (08040\*\*\*\*)**

Insulators for indoor applications with high pollution and outdoor applications, up to 1000 V rated voltage. They are only used when the current collector is inserted from below.

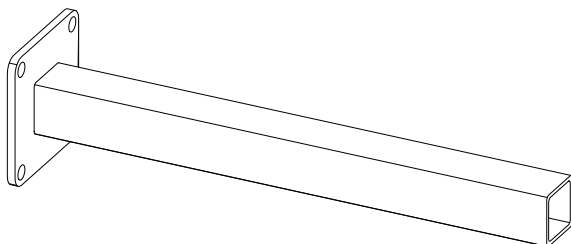

Fig. 37: Towing arm for current collector (steel, galvanized)

■ **Towing arm (020197-\*\*\*) for current collectors**

Used to tow the current collector along. The towing arm is attached to mobile consumers.

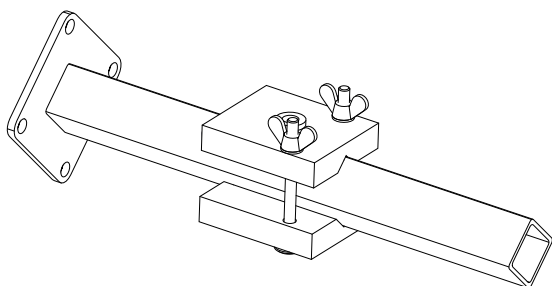

Fig. 38: Drilling jig

■ **Drilling jig for systems with a pickup guide (08-W100-0223)**

In order to meet the requirements of the VDE regulations, a hole must be drilled in the towing arm of systems with pickup guides with the drilling jig, which is used to accommodate the bolt on the protective conductor current collector (PE protection against interchanging).

## Insulated Conductor Rail System

### SinglePowerLine Program 0813

---

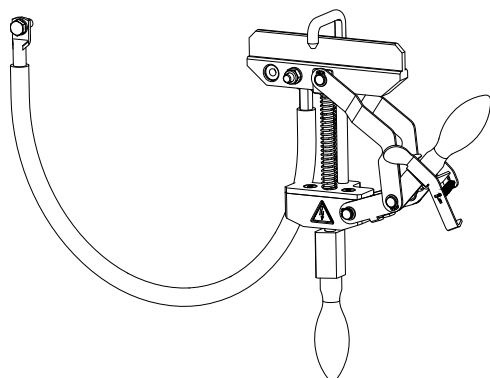

Fig. 39: Grounding and short-circuit device

- **Grounding and short-circuit device (08-V015-0441\*)**

The grounding and short-circuit device is a protective device for service and maintenance work (see MV0813-0010).

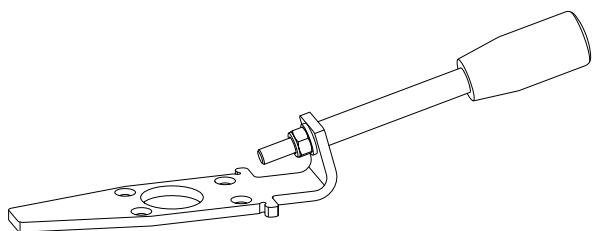

Fig. 40: Tool 1

- **Disassembly tool 0813 (08-V015-0493)**

The disassembly tool consists of two tools and is an aid for removing a hanger clamp from the conductor rail. Tool 1 is pushed between the hanger clamp and conductor rail, while Tool 2 opens the hanger clamp.

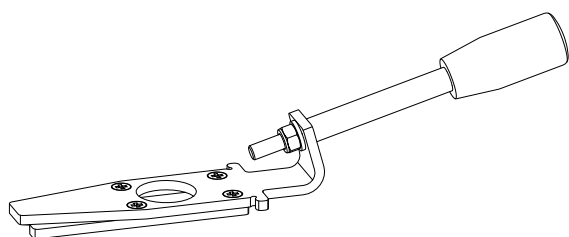

Fig. 41: Tool 2

## Insulated Conductor Rail System

SinglePowerLine Program 0813

---

### 5 Transport, Packaging and Storage

---

#### 5.1 Safety

Recommended protective equipment:



**DANGER!**

#### **Risk of death due to suspended loads!**

Falling parts or uncontrolled swinging loads can lead to severe injury or even death.

- Never walk under suspended loads.
- Only use the attachment points provided; do not fasten lifting accessories to protruding machine parts or to eyelets on components.
- Ensure that lashing components are properly seated.
- Use only authorized lifting accessories and lashing components with sufficient load capacity.
- Do not use torn or damaged ropes or straps; replace them with new ones.
- Do not attach ropes or straps at sharp corners and edges, and do not knot or twist them.
- Only move loads under supervision.
- Set down the load before leaving the workplace.
- Cordon off the work area.
- Use caution when working in the vicinity of, and particularly below, the conductor rail system.



**DANGER!**

#### **Risk of injury due to crushing of skin and limbs!**

Skin and limbs can be crushed:

- When packing components and handling long loads.
  - If transport crates are dropped.
  - With incorrect suspension points for transport crates.
  - With incorrect and unauthorized loading of transport crates.
- Wear personal protective equipment!
- Use suitable lifting gear!

## Insulated Conductor Rail System

### SinglePowerLine Program 0813

---



**DANGER!**

#### **Risk of injury due to impacts and punctures/stabs from conductor rails sliding out!**

Risk of injury due to impacts and punctures/stabs from conductor rails sliding out when the packaging units are held at an angle, the packaging is damaged or through carelessness with long loads/transport crates.

- Wear personal protective equipment!
- Cordon off the work area!
- Use caution when working in the vicinity of, and particularly below, the conductor rail.
- Do not step under suspended loads!
- Before lifting, ensure that the packaging/transport crate is undamaged!



**WARNING!**

#### **Risk of injury due to cutting and amputation!**

Cuts and amputations can occur:

- On the packaging material (e.g.: cartons, bands, etc.).
- On sharp edges of the conductor rail.

- Wear personal protective equipment!



**WARNING!**

#### **Risk of injury due to puncture wounds and cuts!**

The packaging material can contain sharp objects such as nails, struts, steel bands and wood splinters that can cause injury to limbs.

- Wear personal protective equipment!
- Cordon off the work area!



**NOTE!**

#### **Damage due to improper transport!**

Improper transport can result in substantial property damage.

- When unloading packaged parts upon delivery and during internal transport, proceed with caution and observe the symbols and information on the packaging.
- Only use the attachment points provided.
- Only remove packaging shortly before installation.

## 5.2 Transport

Immediately upon receipt, check the delivery for completeness and transport damage.

In case of visible damage, proceed as follows:

- Do not accept delivery or accept it only with reservations.
- Note the scope of damage on the transport documents, or on the transporter's delivery note.
- Initiate a complaint with photos of the damage, if possible.

## Insulated Conductor Rail System

### SinglePowerLine Program 0813

---



**NOTE!**

**File a complaint on each defect as soon as it is detected. Damage compensation claims may only be made within the applicable claim periods.**

### 5.3 Packaging

The individual packages are packed appropriately for the expected transportation conditions.

The packaging has the function of protecting the individual components against damage, corrosion, etc. until they are finally installed. Hence, do not destroy the packaging; remove it only shortly before installation.

#### Handling packaging materials:

Dispose of packaging material according to applicable legal regulations and local guidelines.



**CAUTION!**

#### **Environmental damage due to improper disposal!**

Packaging materials are valuable raw materials and can be reused in many cases or sensibly reconditioned and recycled.

- Dispose of packaging materials in an environmentally appropriate manner.
- Comply with locally applicable disposal guidelines; if necessary, engage a specialist to handle disposal.

### 5.4 Storage of packaged parts

**Store packaged parts under the following conditions:**

- Do not store outdoors.
- Store in a dry, dust-free place.
- Do not expose to aggressive media.
- Protect from direct sunlight.
- Avoid mechanical vibrations.
- Storage temperature: -30 to +40°C.
- Relative air humidity: Maximum 60% without condensation.
- In case of a storage time of more than 3 months, check the general condition of all parts at regular intervals. If necessary, refresh or replace the preservative.



**NOTE!**

**In some cases, there may be instructions for storage on the packaged parts that go beyond the requirements listed here!**

- Follow the instructions accordingly.

## Insulated Conductor Rail System

SinglePowerLine Program 0813

---

### 6 Installation

---

#### 6.1 Safety

- Installation and commissioning may only be conducted by specially trained technicians!

Recommended protective equipment:



#### **Risk of death due to suspended loads!**

Falling loads can cause serious injuries or even death.

- Never walk under suspended loads.
- Only move loads under supervision.
- Set down the load before leaving the workplace.
- Wear personal protective equipment!



#### **Risk of injury due to improper installation!**

Improper installation can result in serious injury to persons and property.

- Before starting work, ensure that there is sufficient space for the installation.
- Handle open, sharp-edged components carefully.
- Ensure the installation area is clean and tidy! Loosely stacked or scattered components and tools are a source of hazards.
- Install components properly. Comply with the specified screw tightening torques.



#### **Poisonous vapors/gases during fire!**

The standard insulation materials contain PVC. Poisonous vapors/gases (HCL) can be produced during fires.

- The system operator must take this into account throughout the entire facility accordingly when planning and take the appropriate protective measures against fires.
- Halogen-free materials can be used on request.
- The building must be evacuated immediately!
- Notify the fire department!

## Insulated Conductor Rail System

### SinglePowerLine Program 0813

---



**DANGER!**

#### **Risk of injury due to crushing of skin and limbs!**

There is a risk of crushing of skin and limbs due to:

- Spring force/gravity (stored energy).
- Current collector (spring force) during preassembly, installation, disassembly and maintenance.
- Falling conductor rail system components, if they have not been properly installed or if operated under inappropriate operating conditions (e.g., environment that contains solvents).
  - Only allow installation to be conducted by specialized technicians.
  - When changing the sliding contact, follow the separate instructions for this task. See Section 12.1.
  - Only install the conductor rail system where suitable operating conditions prevail. See Section 3.3.
  - Wear personal protective equipment!



**DANGER!**

#### **Risk of injury due to crushing of skin and limbs!**

Skin and limbs can be crushed:

- When packing components and handling long loads
- If transport crates are dropped
- With incorrect suspension points for transport crates
- With incorrect and unauthorized loading of transport crates
- Wear personal protective equipment!
- Use suitable lifting gear!



**DANGER!**

#### **Risk of injury due to ensnarement or impact!**

An ensnarement and/or impact with moving conductor rails (slip ring) or current collectors connected to the machine and other components must be prevented.

- Cordon off the work area.
- The main power supply (from the building) must be disconnected in the installation area and secured against switching on again.
- Use caution when working in the vicinity of the danger zone, in particular if protective devices (covers, enclosures, control devices, etc.) have been removed or deactivated.
- Use caution when working in the vicinity of the danger zone, particularly below the conductor rail.
- Wear personal protective equipment!

## Insulated Conductor Rail System

### SinglePowerLine Program 0813

---



**DANGER!**

#### **Risk of injury due to cutting and amputation!**

Cuts and amputations can occur:

- On sharp edges of the general components.
- On sharp edges of the conductor rails.
- On cut edges when trimming the conductor rails.
- On packaging materials (cartons, bands, etc.).

→ Wear personal protective equipment!



**DANGER!**

#### **Risk of injury due to puncture wounds and cuts!**

The packaging material can contain pointed and sharp objects such as nails, struts, steel bands and wood splinters that can cause injury to limbs.

→ Wear personal protective equipment!

→ Cordon off the work area!



**DANGER!**

#### **Risk of injury due to impacts and punctures/stabs from conductor rails sliding out!**

Risk of injury due to impacts and punctures/stabs from conductor rails sliding out when the packaging units are held at an angle or through carelessness with long loads/transport crates.

→ Wear personal protective equipment!

→ Cordon off the work area!

→ Use caution when working in the vicinity, particularly below the conductor rail!

→ Do not step under suspended loads!

→ Before lifting, ensure that the packaging/transport crate is undamaged!

## Insulated Conductor Rail System

### SinglePowerLine Program 0813

---



**DANGER!**

#### **Risk of death due to electrical shock!**

Contact with components carrying electrical power can lead to death or severe injury due to electrical shock. Danger of injury due to shock reactions, falling or being thrown across the room due to electrical shock.

- The main power supply (from the building) and heater power supply must be disconnected in the installation area and secured against switching on again.
- Disconnect all voltage supply to the line feeds.
- Observe the 5 Safety Rules (see Section 2.7)!
- Check whether a voltage is still present in the components and take measures where necessary.
- Attach a sign stating "Risk of Death due to Electrical Shock" with the relevant hazard symbol in all areas with live components.
- The customer must provide grounding for metallic components.
- The customer must provide protective devices.
- Ensure that there is sufficient stability in the area.



**WARNING!**

**The system must be designed and operated according to the prevailing ambient conditions!**



**WARNING!**

#### **Secure components against falling!**

Possible falling components must be determined in the customer analysis as part of the operator's risk and hazard analysis.

- The operator must take appropriate measures.
- With an installation height of 3 m or more in areas with pedestrian traffic, the conductor rails must be secured against falling.

## Insulated Conductor Rail System

### SinglePowerLine Program 0813

---

#### 6.2 Provide additional protection against contact at the conductor rail end.

An end cap is attached to the conductor rail end as protection against contact. In the case of double current collectors, a sliding contact that is **under voltage** can protrude from the end cap at the end of the conductor rail during operation. Touching this sliding contact may cause injury due to an electrical shock as well as by falling or being thrown across the room. The system operator must ensure that the current collector does not protrude or must ensure that the danger area is inaccessible (e.g., by providing protection against contact).



**DANGER!**

#### **Take constructive protective measures!**

- Use control technology to ensure that the current collector never travels beyond the conductor rail end or
- Install additional protection against contact that covers the sliding contact in a contact-proof manner when leaving the conductor rail.



**DANGER!**

#### **Alert personnel to the danger!**

- Attach a sign stating "Risk of Death due to Electrical Shock" with the relevant hazard symbol in all areas with components under voltage.

## Insulated Conductor Rail System

### SinglePowerLine Program 0813

#### 6.3 System arrangement

The following illustration provides an overview of the arrangement of the components and distances in a conductor rail system.

Conductor Rail System 0813 with hanger clamps on support arms

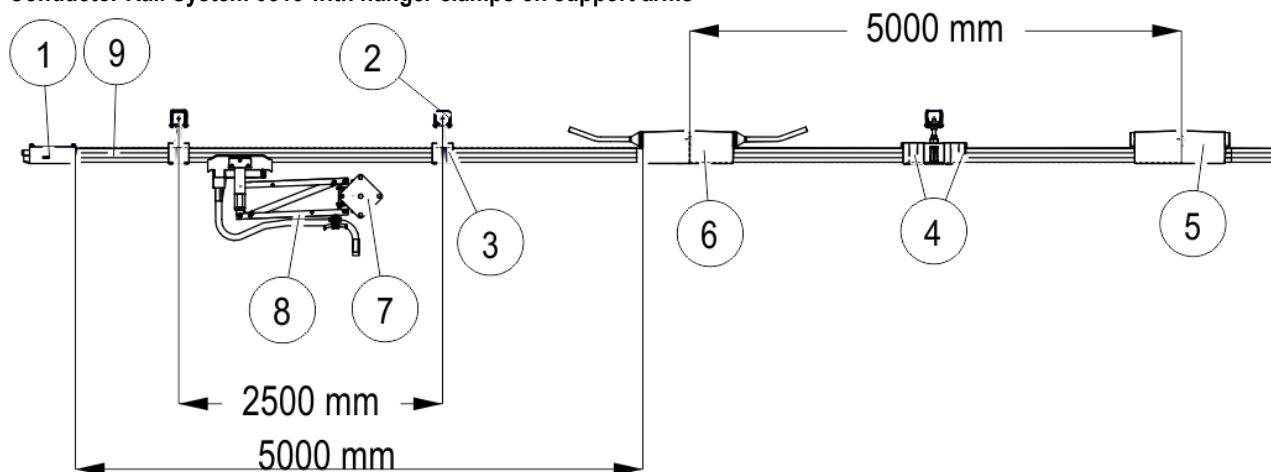

Fig. 42: Components in a conductor rail system

1	End cap
2	Support arm with bracket
3	Hanger clamp
4	Anchor clamps
5	Connector
6	Line feed
7	Towing arm for current collector
8	Current collector
9	Conductor rail

## Insulated Conductor Rail System

### SinglePowerLine Program 0813

---

#### 6.4 Installation of mechanical components

##### 6.4.1 Required tools

- Standard tools:
  - Measuring tape
  - Calipers
  - Scribe
  - Cutting tool (e.g., precision saw, angle grinder with fine cutting disk)
  - File for deburring cut edges after trimming
  - Cordless drill
  - Screwdriver set
  - Hexagon screwdriver SW 5
  - Open-end wrench SW 17
  - Torque wrench with a measuring range from 5 Nm to 50 Nm and suitable attachments (internal hexagon: SW 5, external hexagon: SW 8, SW 10 and SW 17)
  - Disassembly tool (for disassembling hanger clamps) (Order No.: 08-V015-0493)
- Special tools:
  - Mounting comb (Order No.: 081046\*)
  - Drilling jig for systems with guides (Order No.: 08-W100-0223)
  - Contact grease/conductive paste (Order No.: 080021\*)

##### Personnel:

- Installation only by technical personnel, at least 2 persons

##### 6.4.2 Trim conductor rail

The customization of components is limited to the trimming of the conductor rail.



##### **NOTE!**

**Do not adapt the conductor rail when it is installed, but rather conduct the work at a separate workstation!**

**The cutting of the conductor rail must be conducted away from the installation area!**

The conductor rails have a standard length of 5000 mm. Shorter lengths are available but are typically produced at the installation site.

## Insulated Conductor Rail System

### SinglePowerLine Program 0813

---

#### Required tools:

- Fine saw or angle grinder with a fine cutting insert
- File for deburring the ends, e.g., smooth file

#### Work steps:

- Pull the insulating profile off the conductor bar.

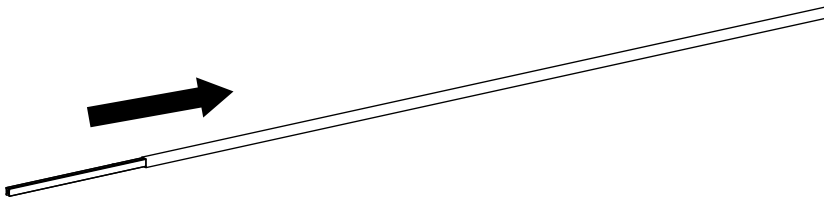

Fig. 43: Remove the insulating profile from the conductor bar

- If the conductor bar is sawed, the cutting direction must be kept from top to bottom (see Fig. 44).



#### NOTE!

#### Maintain the cutting direction for the conductor bar!

If the cutting direction from top to bottom is not maintained, the rolled-in stainless steel strip will loosen in the conductor bar.

- Always adhere to the cutting direction!

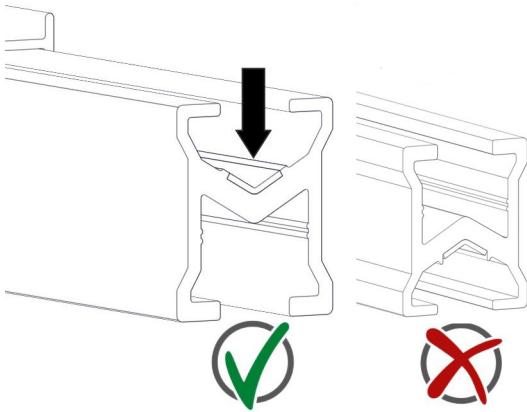

Fig. 44: Note the sawing direction for the conductor bar

- Saw the insulating profile accordingly. It must always be 2x92.5 mm shorter than the conductor bar.



Fig. 45: The insulation profile is shorter than the conductor bar

- Chamfer the conductor bar on the contact surface with approx. 1-2 mm 45° to ensure a perfect passage of the sliding contact over the rail joint.
- Deburr all edges of conductor bar and insulation profile with a small file. **There must be no sharp edges left.**

## Insulated Conductor Rail System

### SinglePowerLine Program 0813

---

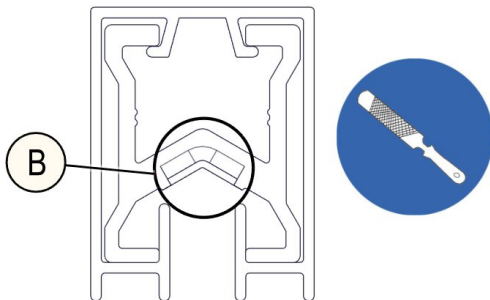

Fig. 46: Deburr conductor bar and insulation profile



#### NOTE!

**Sharp edges lead to increased wear of the sliding contacts or even to the failure of the system!**

A sharp edge or burr can quickly wear away the sliding contacts. Therefore, deburring at the ends of the contact surface (B in Fig. 46) is necessary!



Use the QR code ("click" or "scan") to see our animation **Cutting Rail**.

## Insulated Conductor Rail System

### SinglePowerLine Program 0813

---

#### 6.4.3 Install conductor rail system

##### Procedure for the installation:

It is sensible to start the installation at one end cap and install the conductor rail along the route.

##### Work steps:

- Indicate the installation location for line feeds, customer-side fixed points, terminal boxes, expansion points, air gaps and the course of the conductor rail on the installation structure according to the layout and allocation plan on the substructure.
- Prepare the line feed and pickup guide (if present).
- Install the conductor rail (see Section 6.4.3.1).
- Install conductor rail sections.
- Check the mechanical installation.

##### Test steps to be performed during installation:

- Check the design against the layout and allocation plan.
- Maintain the hanger clamp distances; the rails must be audibly engaged in the hanger clamp.
- All transfers and bends must be tested for functionality. Current collectors must not jam when passing through. Check for free passage with a single current collector.
- Cable routing (laying, marking, etc.) must be checked.
- Check the horizontal and vertical deviation of the conductor rail system! The deviation from the ideal line may be max.  $\pm 5$  mm.

## Insulated Conductor Rail System

### SinglePowerLine Program 0813

---

#### 6.4.3.1 Mount hanger clamps



#### NOTE!

The maximum tightening torques must not be exceeded (14 Nm for a standard hanger clamp with steel nut). Too high tightening torques will damage the hanger clamp.



#### NOTE!

**The hanger clamp fastening must be adapted to the respective application!**

The fastening elements are designed for standard fastening applications. For safety-critical fastenings, special on-site interfaces (e.g., deviating through-hole geometry or other restrictions affecting the fastening) and/or increased requirements (e.g., vibration), the fastening must be adapted to the respective application (e.g., by means of additional screw locking with Loctite 242). The system manufacturer is responsible for the evaluation.

#### Required tools:

- Mounting comb (Order No.: 081046\*)
- Torque wrench with a measuring range from 5 Nm to 50 Nm and socket SW 17

The hanger clamps are available in versions with square nuts for mounting in support arms/C-rails (see Fig. 47) or hexagon nuts (see Fig. 48) as well as with or without an insulator (see Fig. 12). A version with a hexagon nut is recommended for current collector insertion from the side.

Insulators are required for indoor applications with high levels of pollution and outdoor applications and allow a rated voltage of up to 1000 V (with current collector insertion from below).

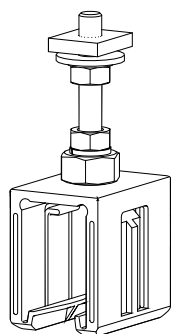

Fig. 47: Hanger clamp with square nut

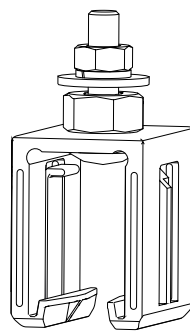

Fig. 48: Hanger clamp with hexagon nut

**Insulated Conductor Rail System**

SinglePowerLine Program 0813

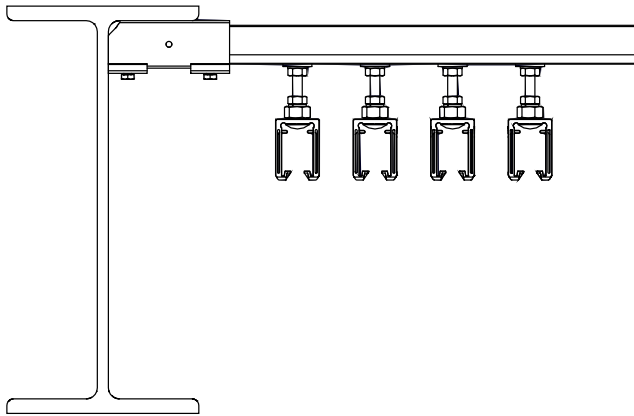

Fig. 49: Hanger clamps with square nuts mounted in the support arm

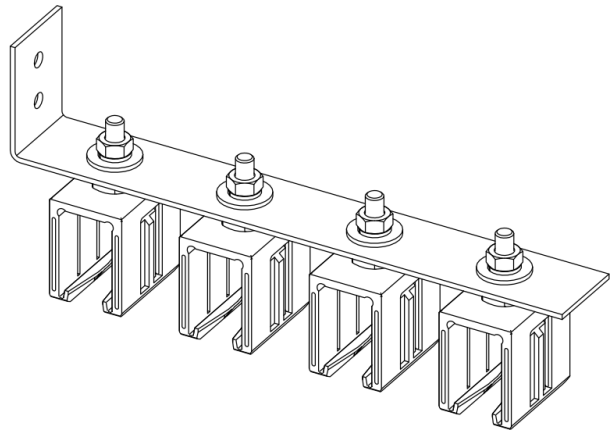

Fig. 50: Hanger clamps with hexagon nuts mounted with retaining plate

**Requirements:**

The support structure (e.g., support arm or retaining plate) is mounted at the appropriate distance (see project-specific documents).

**Distance between hanger clamps:**

First hanger clamp to end cap:  $\geq 250$  mm (up to max. 400 mm)

Second hanger clamp after end cap: 1750 mm

Third hanger clamp after end cap: 1750 mm

Hanger clamp to fourth hanger clamp:  $\leq 2500$  mm

**Work steps (mounting with support arm/C-rail):**

- Slide the first hanger clamp onto the support arm/C-rail (see Fig. 51). Please refer to the project-specific documents for the exact dimensions.
- Tighten the first hanger clamp with the specified torque (SW 17, torque wrench: 14 Nm) (see Fig. 52).
- Slide the next hanger clamp into the support arm/C-rail (see Fig. 53).

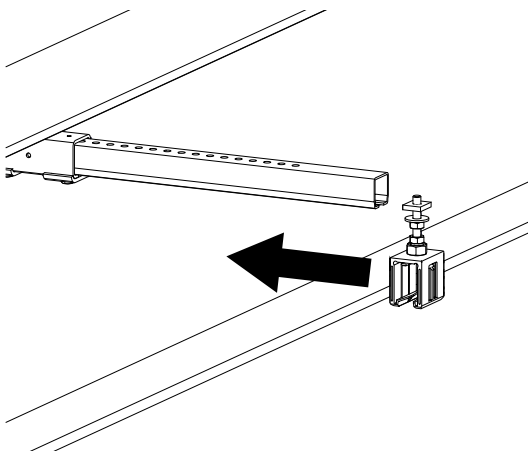

Fig. 51: Slide the first hanger clamp onto the support arm

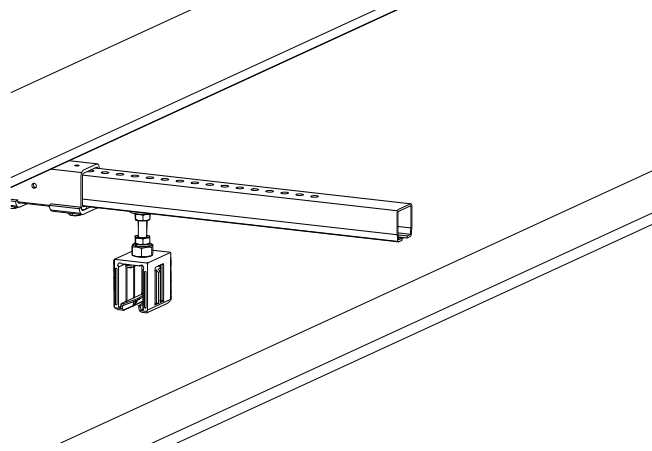

Fig. 52: First hanger clamp slid onto the support arm and tightened

## Insulated Conductor Rail System

### SinglePowerLine Program 0813

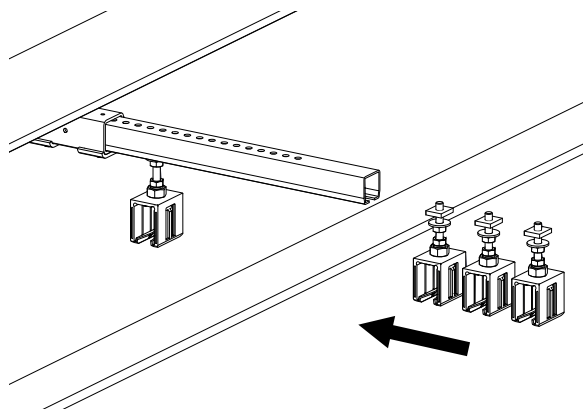

Fig. 53: Slide the next hanger clamp onto the support arm

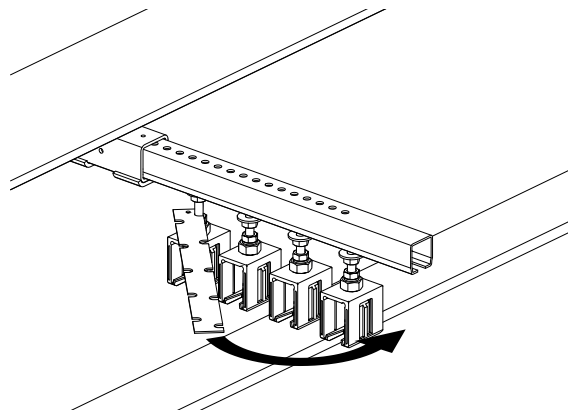

Fig. 54: Align the hanger clamps using the mounting comb

- In order to achieve an even phase offset, the next hanger clamps must be aligned with the mounting comb (see Fig. 54). The phase offset of either 80 mm (standard) or 70 mm (reduced) can be set with the mounting comb. Depending on which phase offset is to be implemented, the corresponding side (4x80 mm or 4x70 mm) of the mounting comb must be used (see Fig. 55).

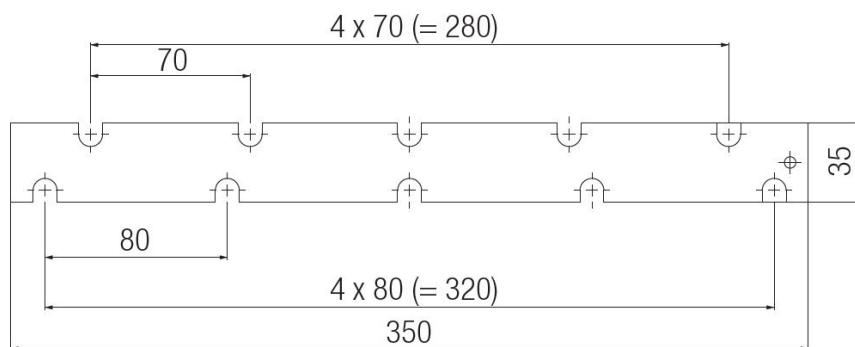

Fig. 55: Dimensions on the mounting comb

- After the hanger clamps have been aligned, tighten the next hanger clamps with the specified torque (SW 17, torque wrench: 14 Nm) and remove the mounting comb. A subsequent alignment is not necessary.
- Mount the other hanger clamps in the same way.

## Insulated Conductor Rail System

### SinglePowerLine Program 0813

---

#### Work steps (for retaining plate with through holes):

→ Loosen the screw connection with the hexagon nut and washers from the hanger clamp (see Fig. 56).

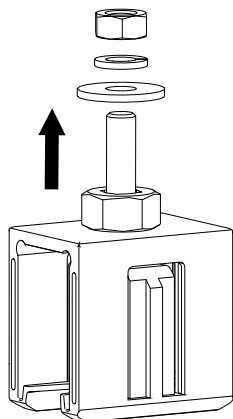

Fig. 56: Loosen the screw connection from the hanger clamp

→ Insert the hanger clamp into the hole in the retaining plate and tighten the screw connections from above with the specified torque (SW 17, torque wrench: **14 Nm**) (see Fig. 57 through Fig. 59). The retaining clamp of the hanger clamp must be rotatable. A subsequent alignment is not necessary.

→ Mount the other hanger clamps in the same way.

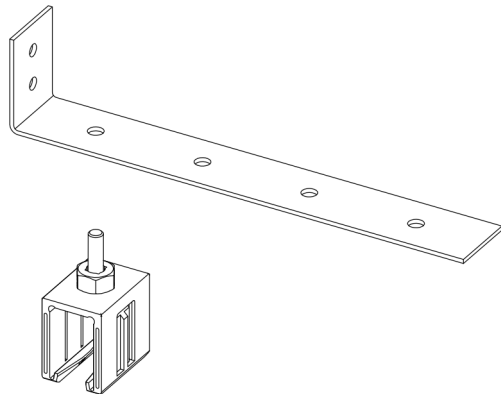

Fig. 57: Insert the hanger clamp into the first hole in the retaining plate

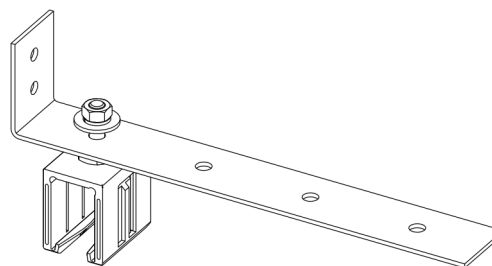

Fig. 58: The hanger clamp is screwed on from above

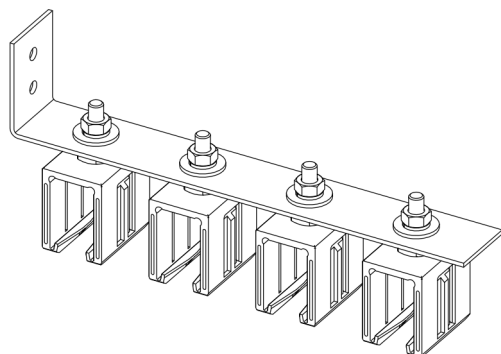

Fig. 59: All hanger clamps are mounted

## Insulated Conductor Rail System

### SinglePowerLine Program 0813

---



Use the QR code ("click" or "scan") to see our animation **Mounting Hanger Clamps**.

#### 6.4.3.2 Mount conductor rail



**WARNING!**

#### Secure components against falling!

Possible falling components must be determined in the customer analysis as part of the operator's risk and hazard analysis.

→ The operator must take appropriate measures.

#### Requirements:

The hanger clamps are correctly mounted on the support structure.

#### Work steps:

- Mount the conductor rails according to the project-specific documents (note the position of the phases and protective conductor).
- Insert the first conductor rail at approx. 45° into the hanger clamp and clip it in (see Fig. 60). Ensure that the conductor rails engage correctly and the hanger clamp covers the insulation above and below (see Fig. 61).

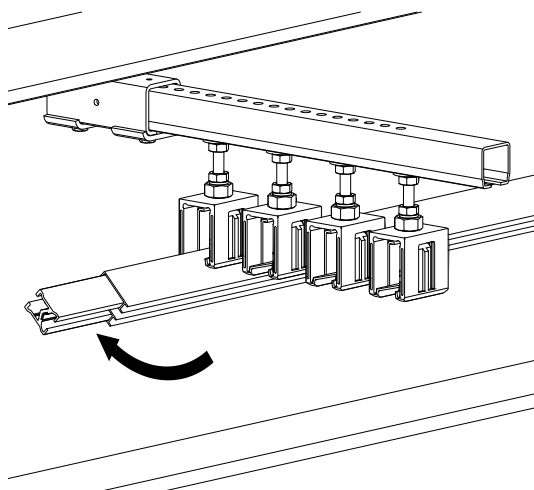

Fig. 60: Clip the rail into the hanger clamp

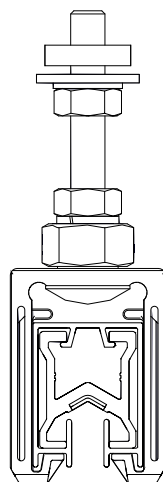

Fig. 61: The rail is clipped into the hanger clamp

- Mount all conductor rails in the same way.

## Insulated Conductor Rail System

### SinglePowerLine Program 0813

#### Disassemble the conductor rails

In the event that a conductor rail has been incorrectly installed and needs to be removed from the hanger clamp, the disassembly tool (Order No.: 08-V015-0493) should be used.

#### Work steps:

- Slide Tool 1 up to the stopper between the conductor rail and hanger clamp (see Fig. 62).
- Press the conductor rail against Tool 1 or against the hanger clamp, respectively (see Fig. 63). At the same time, insert Tool 2 on the open side of the conductor rail (see Fig. 65). The retaining clamp of the hanger clamp bends up (see Fig. 64).

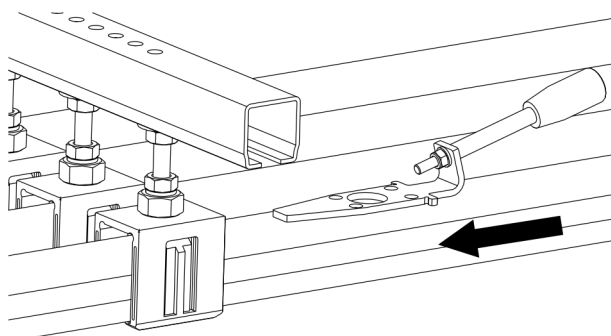

Fig. 62: Slide Tool 1 between the conductor rail and the hanger clamp

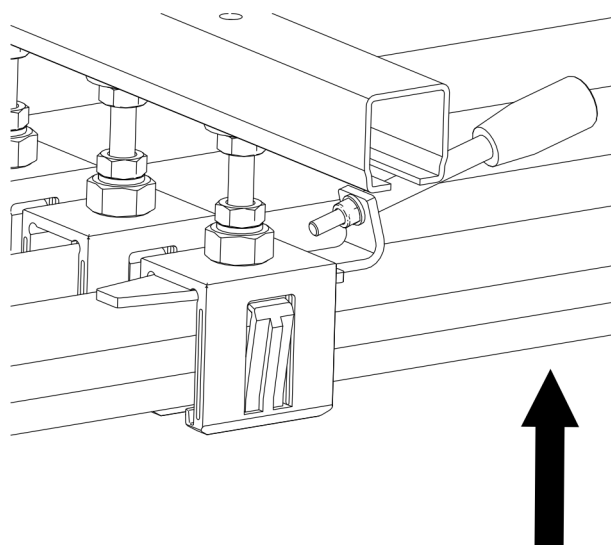

Fig. 63: Press the conductor rail against Tool 1 or against the hanger clamp

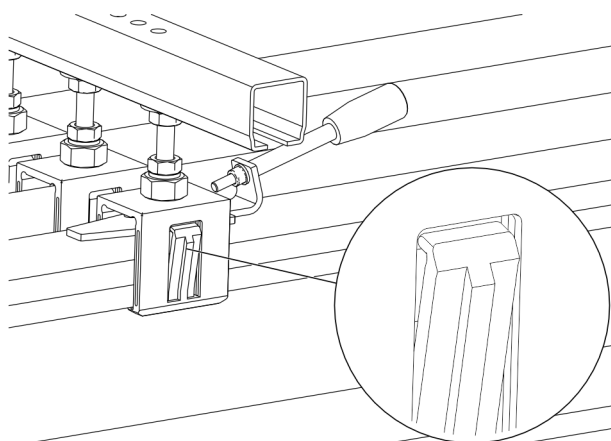

Fig. 64: The retaining clamp of the hanger clamp bends up

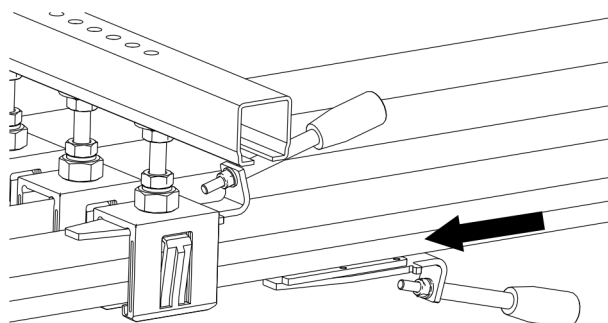

Fig. 65: Insert Tool 2 on the open side of the conductor rail

- Pull out the conductor rail.
- Remove Tool 2 from the open side of the conductor rail (see Fig. 67).

## Insulated Conductor Rail System

### SinglePowerLine Program 0813

---

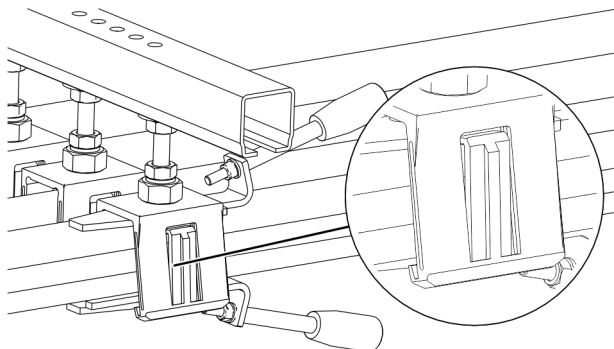

Fig. 66: The hanger clamp bends up

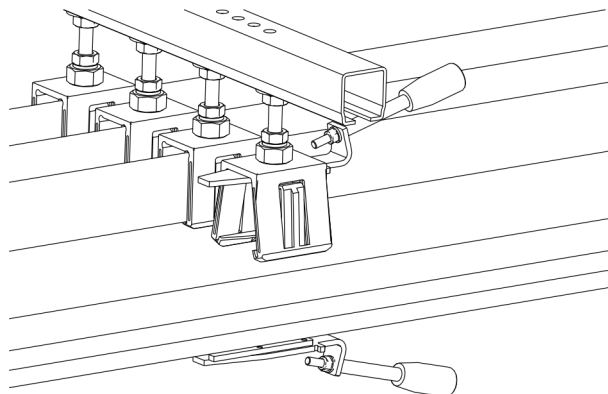

Fig. 67: Remove Tool 2 from the open side of the conductor rail

→ In order to remove Tool 1, the tension spring of the retaining clamp may need to be pushed away.

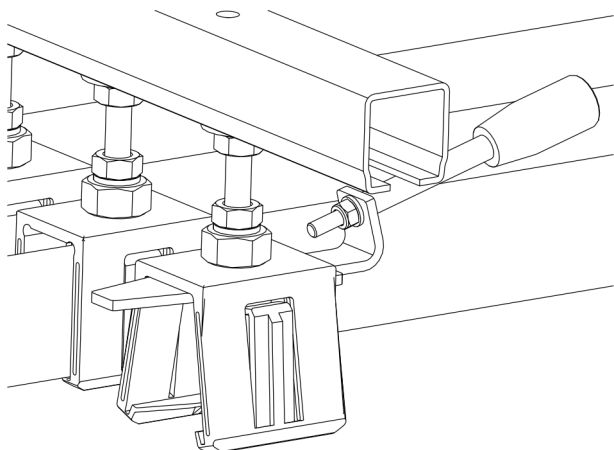

Fig. 68: Remove Tool 1



Use the QR code ("click" or "scan") to see our animation **Disassembly Tool**.

## Insulated Conductor Rail System

### SinglePowerLine Program 0813

---

#### 6.4.3.3 Connect rails

The mechanical and electrical connection of the conductor rail is done by means of a connector. To allow for expansion, the distance between the hanger clamp and connector must be  $\geq 400$  mm!

#### Requirements:

The conductor rails are mounted into the hanger clamp.



**NOTE!**

#### With fixed point mounting:

Before the conductor rails are connected to each other, the anchor clamps must first be slid onto the conductor rails (see Section 6.4.3.5).

Anchor clamps are positioned to the right and left of a hanger clamp.

Please refer to the project-specific documents for the exact position of the anchor clamps.



**NOTE!**

Aluminum-stainless steel and CopperECO conductor rails use the identical connector. A mixed installation of these two types of conductor rail is permitted.

#### Required tools:

- Crosshead screwdriver
- Contact grease/conductive paste (Order No.: 080021)
- Steel brush
- Torque wrench with a measuring range from 5 Nm to 50 Nm and socket SW 17

#### Work steps:



Abb. 69: Clean the contact surfaces until they are bare metal and apply a thin layer of conductive paste.

→ Slide one insulating cap half (Pos. 1) of the connector over the rail ends (see Fig. 70).

Insulated Conductor Rail System

SinglePowerLine Program 0813

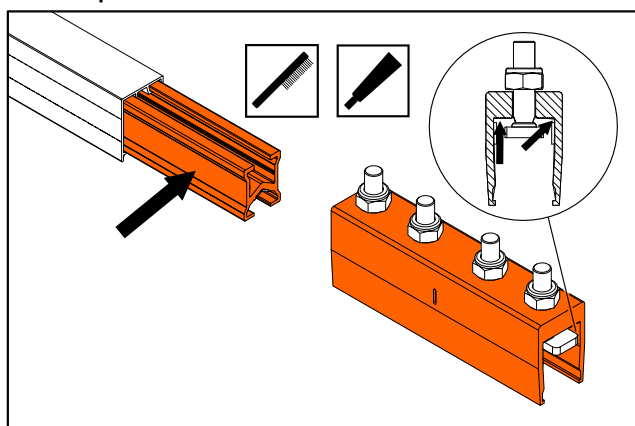
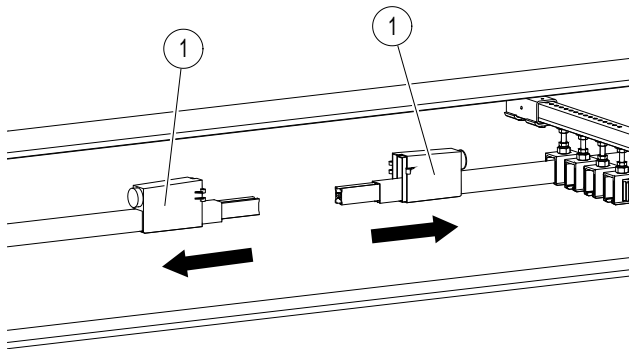

Fig. 70: Slide one insulating cap half of the connector over the rail ends

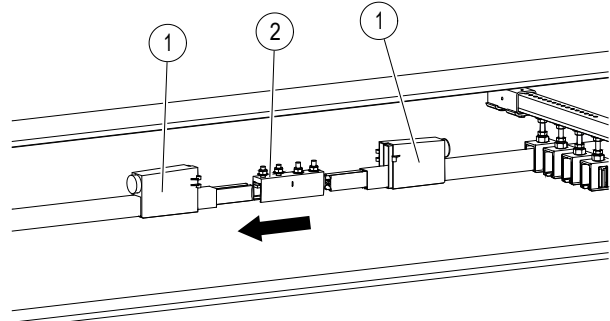

Fig. 71: Slide the connector into the first conductor bar end through to the stopper

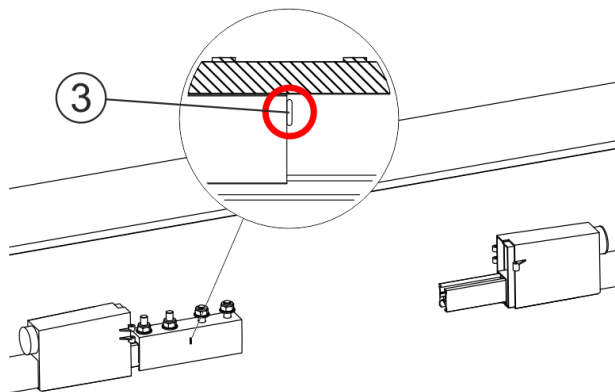

Fig. 72: Connector with stopper (Pos. 3) (aluminum-stainless steel or CopperECO conductor rail) - slid into the first conductor bar end

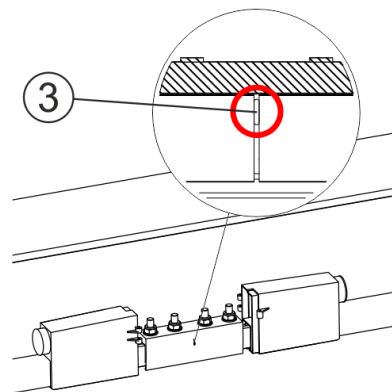

Fig. 73: Connector with stopper (Pos. 3) (aluminum-stainless steel or CopperECO conductor rail) - slid into both conductor bar ends

→ Slide the connector (Pos. 2) through to the stopper (Pos. 3) in the first conductor bar end (see Fig. 71 and Fig. 72). Depending on the function, a gap of 2 to max. 3 mm between the rail ends is functionally necessary. The clamping plate (Pos. 7, see Fig. 79) must lie in the hollow profile of the conductor bar.



**NOTE!**

**In the case of aluminum-stainless steel conductor rails as well as CopperECO, there is a stopper that ensures the functionally necessary gap of 2 to 3 mm between the rail ends. In the case of copper conductor rails, there is an inspection window instead (see Fig. 74) to check whether the gap is being maintained!**

## Insulated Conductor Rail System

### SinglePowerLine Program 0813

---

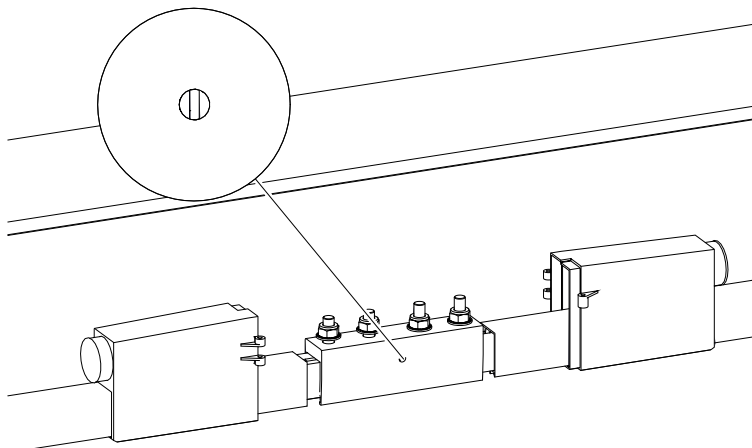

Fig. 74: Connector with inspection window (copper conductor rails)

- Slide the conductor bar of the second rail end up to the stopper (Pos. 3) of the connector (see Fig. 75).
- Tighten the M10 nuts of the connector with the specified torque (SW 17, torque wrench: **31 Nm**).

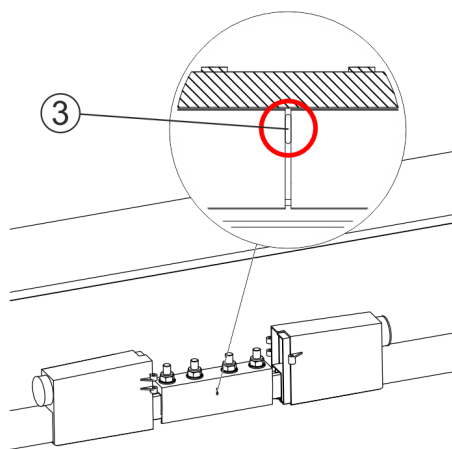

Fig. 75: Slide the second end of the rail into the connector

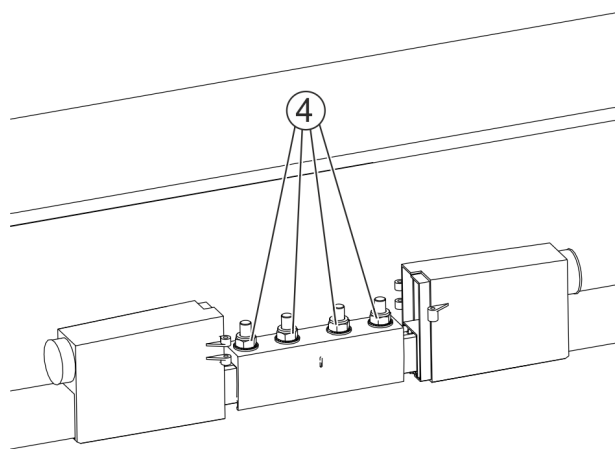

Fig. 76: Tighten M10 nuts

- Slide the insulating cap halves of the connector over the connection point (see Fig. 77) and tighten the two fillister head tapping screws (Pos. 6) (see Fig. 78).

**Insulated Conductor Rail System**  
SinglePowerLine Program 0813

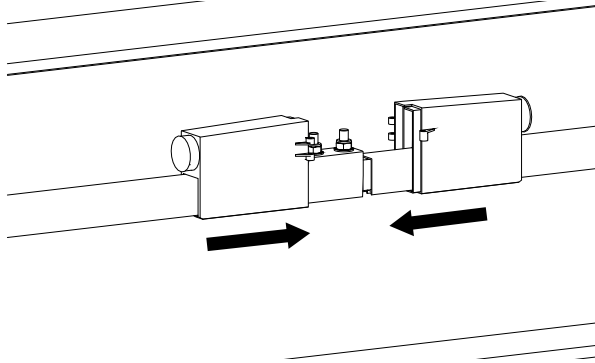

Fig. 77: Slide the insulating cap halves of the connector over the connection point

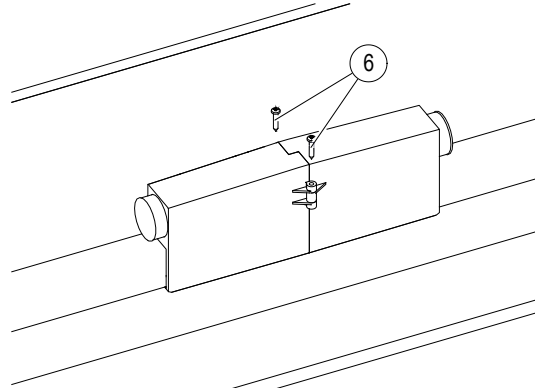

Fig. 78: Screw on the insulating cap halves of the connector

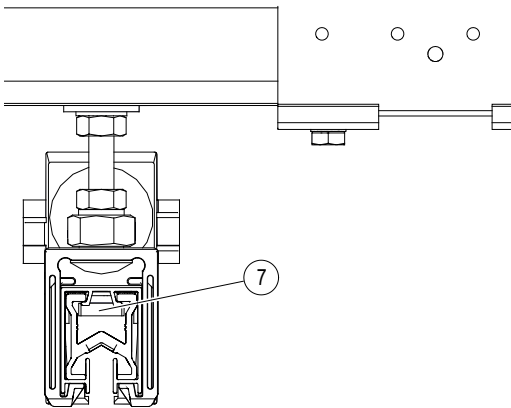

Fig. 79: The clamping plate of the connector lies in the hollow profile of the connector

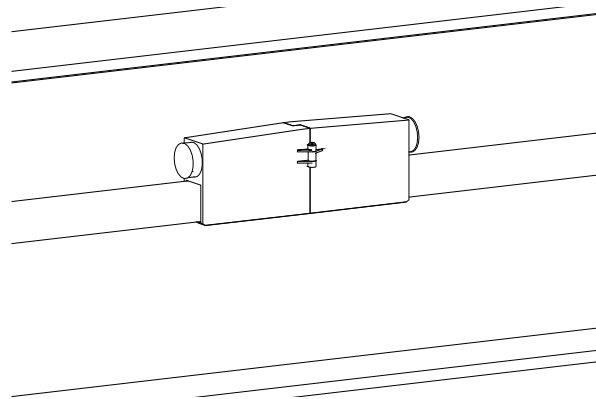

Fig. 80: Connection point 0813 with insulating cap halves

→ Mount each connection point in the same way.



**Avoid destroying the conductor rail!**

- Do not slide the conductor rails together with force.
- Do not strike them with a hammer.
- Observe the tightening torques and use a torque wrench.
- Use contact grease/conductive paste (Order No.: 080021).



Use the QR code ("click" or "scan") to see our animation **Connecting Rails and Mounting Line Feed**

## Insulated Conductor Rail System

### SinglePowerLine Program 0813

---

#### 6.4.3.4 Mount line feed

The electrical line feeds that are used instead of the rail connectors must be mounted as close as possible to the feed cable of the permanent installation (see Section 6.4.3.3). If the line feed is provided within a section of rail that has been cut to length, the insulating profile must be separated there and shortened by 92.5 mm on both sides (see Section 6.4.2).

#### Required tools:

- Torque wrench with a measuring range from 5 Nm to 50 Nm and socket SW 17
- Contact grease, Order No.: 080021
- Steel brush
- Crosshead screwdriver
- Crimping tool
- Hot air dryer

#### Distances:

Distance between the line feed and hanger clamp: Min. 400 mm (due to temperature shift of the conductor rails).



Please refer to the project-specific documents for the exact position of a line feed.

#### Requirements:

The ends of the conductor rail are deburred (see Fig. 46). The line end of the line feed is stripped.

#### Work Steps



Abb. 81: Clean the contact surfaces until they are bare metal and apply a thin layer of conductive paste.

→ Slide the insulating cap halves (Pos. 1) of the line feed over the ends of the conductor rail (see Fig. 82).

## Insulated Conductor Rail System

### SinglePowerLine Program 0813

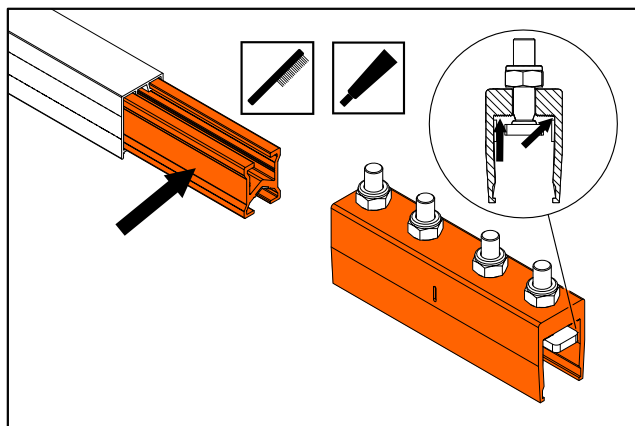
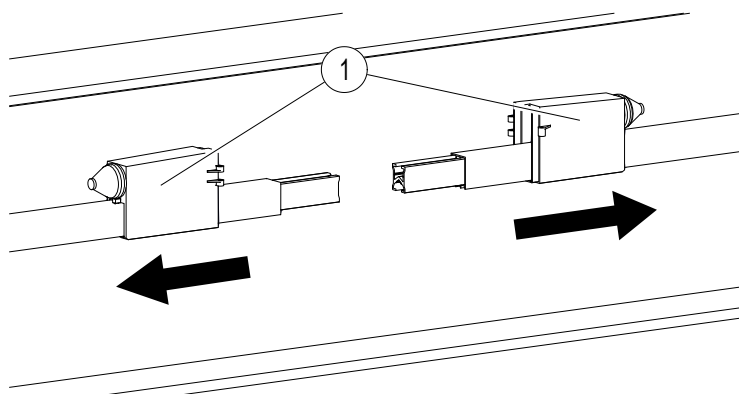

Fig. 82: Slide the insulating cap halves onto the conductor rail ends

- Cut a rubber sleeve (Pos. 3) according to the cable diameter and slide the stripped ends of the connecting cable (Pos. 2) through the sleeves (one-sided or two-sided connection possible).



For better sealing, Conductix-Wampfler recommends pulling a shrink tube over the cable beforehand and connecting it to the sleeve with a hot air blower after installation.

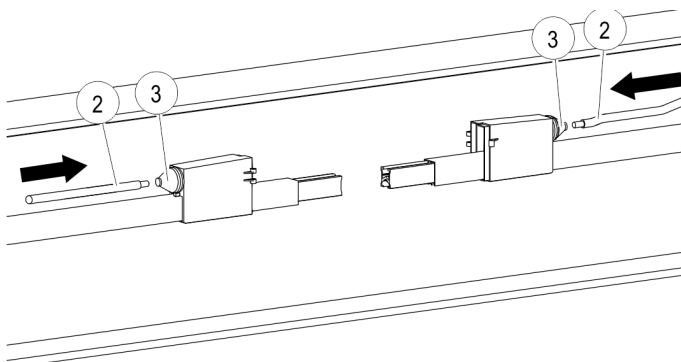

Fig. 83: Slide the cable ends through the sleeves

- To ensure a good current transfer over the long term, the conductor rail ends must be cleaned and thinly coated with contact grease.
- Mount the connector (Pos. 4) with tubular cable lug (Pos. 5) as described in Section 6.4.3.3 (see Fig. 76). Tighten the screw connection with the specified torque (SW 17, torque wrench: **31 Nm**). In the case of copper rails, check via the inspection window whether the ends of the conductor rails are 2 to 3 mm apart (see Fig. 74). With the other conductor bars, it must be ensured that the ends of the conductor rail are in contact with the stopper in the connection plate (see Fig. 73).

# Insulated Conductor Rail System

## SinglePowerLine Program 0813

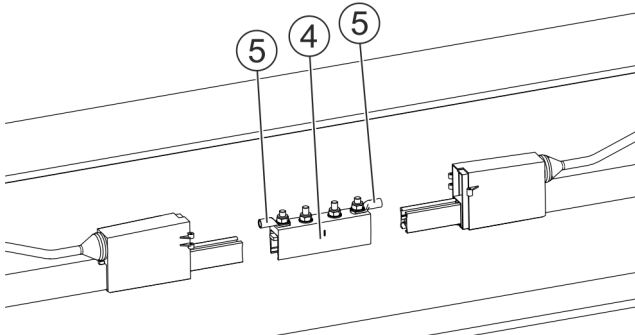

Fig. 84: Mount connector with tubular cable lug

→ Crimp the stripped end of the connecting cable (Pos. 2) with the tubular cable lug (Pos. 5).

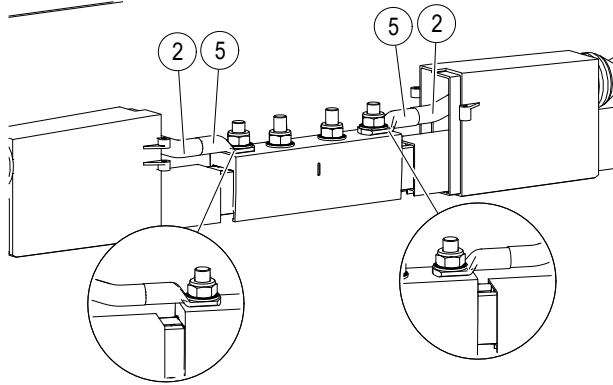

Fig. 85: Crimp cable end (Pos. 2) with tubular cable lug

→ Slide the two insulating cap halves (Pos. 1) together and screw in with two fillister head screws (Pos. 6) (see Fig. 86 and Fig. 87).

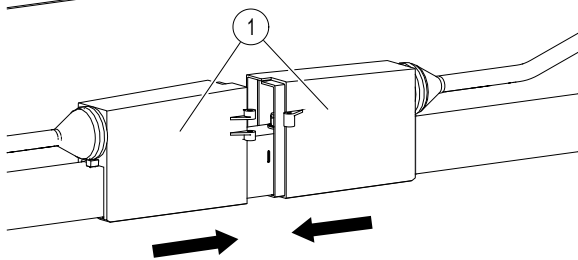

Fig. 86: Slide insulating cap halves together (Pos. 1)

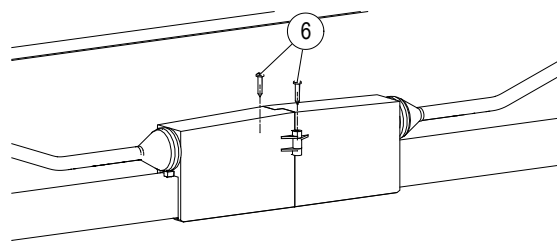

Fig. 87: Screw in insulating cap halves with fillister head screws (Pos. 6)

## Insulated Conductor Rail System

### SinglePowerLine Program 0813

---

→ Mount each line feed in the same way.



**NOTE!**

**Do not allow any tensile stress on the line feed!**

→ Provide the line feed with a strain relief at a suitable distance.

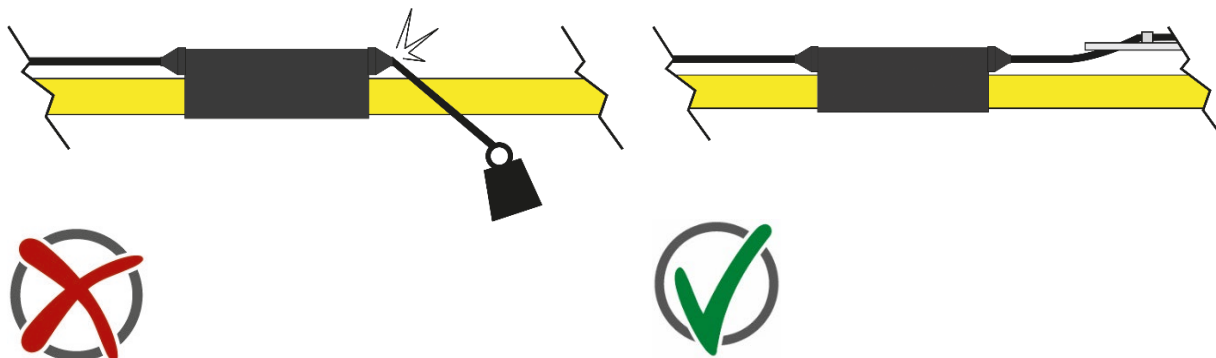

**WARNING!**

**Avoid destroying the conductor rail!**

- Do not slide the conductor rails together with force.
- Do not strike them with a hammer.
- Observe the tightening torques and use a torque wrench.
- Use contact grease/conductive paste (Order No.: 080021).



Use the QR code ("click" or "scan") to see our animation **Connecting Rails and Mounting Line Feed**

## Insulated Conductor Rail System

### SinglePowerLine Program 0813

---

#### 6.4.3.5 Mount anchor clamp

The conductor rail is fixed at one point by means of anchor clamps and can expand freely from this point. The fixed point is typically attached near the line feed. If several fixed points are projected, for example, with transfers or curves (natural fixed point), decouple the route between the fixed points using expansion units. Attachment of the anchor clamp occurs through a clamping cone on the insulating profile.



The conductor rail can normally slide into the hanger clamp. The conductor rail is mechanically fixed within the support structure/substructure using fixed points. It makes sense to always position fixed points of the conductor rail at fixed point positions of the supporting structure.



Please refer to the project-specific documents for the exact position of the fixed points.



**NOTE!**

**Before the conductor rails are connected to each other, the anchor clamps must first be slid onto the conductor rails.**

**Anchor clamps are positioned to the right and left of a hanger clamp.**

#### Required tools:

- Torque wrench with a measuring range from 5 Nm to 50 Nm and socket SW 17

#### Work steps:

- Slide the anchor clamps onto the clipped-in conductor rail section on the right and left (see Fig. 89). When sliding on the anchor clamps, ensure that the two side screws on the anchor clamps point away from the hanger clamp.
- Tighten the two side screws (Pos. 1) (see Fig. 88) on the anchor clamp with the specified torque (SW 8, torque wrench: **10 Nm**). If present, the adjusted air gap of the expansion points in the expansion unit must be checked again on the closest expansion units after the fixed point has been tightened (see Section 6.4.3.6).

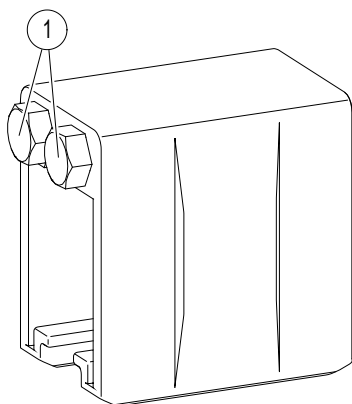

Fig. 88: Side screws on the anchor clamp

## Insulated Conductor Rail System

### SinglePowerLine Program 0813

---

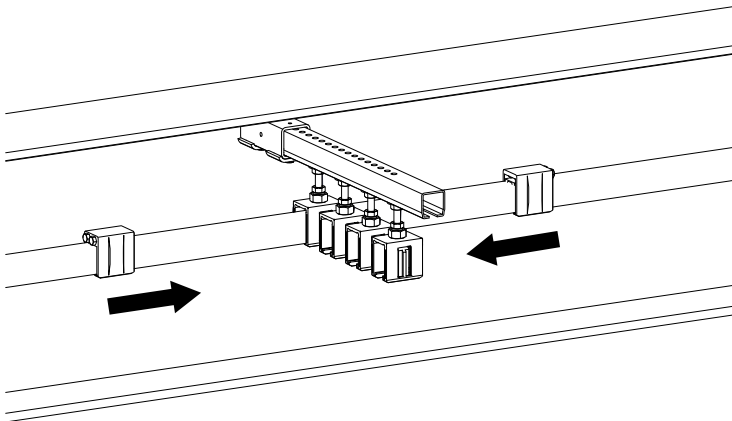

Fig. 89: Slide anchor clamps 0813 onto the conductor rail

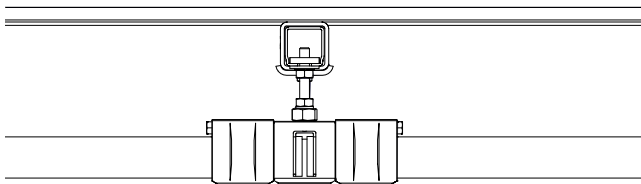

Fig. 90: Anchor clamp is mounted to the right and left of the hanger clamp

→ Mount each anchor clamp in the same way.



Use the QR code ("click" or "scan") to see our animation **Mounting Anchor Points**

## Insulated Conductor Rail System

### SinglePowerLine Program 0813

---

#### 6.4.3.6 Mount heating wire (optional)

In order to increase the system availability during winter operations, conductor rail systems in outdoor systems or similar environmental conditions are additionally provided with a heating system. Conductix-Wampfler GmbH's Conductor Rail Program 0813 is suitable for outdoor use (protected). Therefore, heating should prevent the formation of frost on the conductor rail and the resulting loss of contact with the current collector. The conductor rail is heated using an electrical heating conductor that is fed into the insulation profile. It lies in the hollow cavity of the insulation profile. Each pole of a conductor rail system is heated. Terminal boxes for the electrical connection of the heating wires are used in each case at the line feed and outfeed of a heating conductor circuit.

Among other things, the following must be observed:

- The heating wire is supplied on a coil. An on-site suspension must be provided for the heating conductor coil.
- A cut-out must be made in the insulating profile for the entry and exit points of the heating wire.
- An elongated hole must be made in the insulating profile for the expansion loops of the heating wire.
- All sharp edges must be very well deburred. Burrs damage the insulation of the heating wire.
- After connecting the heating wire, an insulation measurement (see MV0800-0018) must be conducted.



**DANGER!**

#### **Risk of death due to electrical shock!**

Before work on the conductor rail system can begin, the heating must also be disconnected from the power supply! The heating can be designed as a separate electrical circuit and may need to be disconnected from the power separately from the conductor rail.

- Disconnect the power supply of each heating conductor circuit.



**NOTE!**

In all cases, heating requires extensive planning, otherwise neither the function nor the system safety can be guaranteed.

For a detailed description of the installation of the heating system, please read MV0813-0015 and observe the project-specific documents!

## Insulated Conductor Rail System

### SinglePowerLine Program 0813

#### 6.4.3.7 Mount expansion unit

To compensate for temperature-related changes in length for systems > 200 m or sections of the route that are integrated between two fixed points, such as pickup guides at both ends of the section, expansion units are required to accommodate the change in length. The expansion unit has two expansion points, each of which can accommodate a maximum 45 mm expansion. The expansion units are delivered pre-assembled as a conductor rail piece (5 m). The middle section of the expansion unit must be supported with a hanger clamp (not included in the scope of delivery) on the customer's support structure/substructure.

The use of a double current collector is recommended when using expansion units.

#### Required tools:

- Torque wrench with a measuring range from 5 Nm to 50 Nm and socket SW 17

#### Work steps:

- Mount the hanger clamp (not included in the scope of delivery) for the center piece of the expansion unit (see Section 6.4.3.1). Observe the specified torque while doing so (SW 17, torque wrench: **14 Nm**).
- Clip the 5 m piece into the hanger clamp (see Section 6.4.3.1).
- Connect the two rail ends with a connector (see Section 6.4.3.3).
- The size of the air gap depends on the ambient temperature during installation. Determine the air gap dimension, consisting of the expansion point dimensions  $x_1$  and  $x_2$  (see Fig. 91), using the diagram (see **Fehler! Verweisquelle konnte nicht gefunden werden.** or the template diagram in Section 12.2). Set the determined dimension. The sum of  $x_1$  and  $x_2$  must equal twice the diagram value.

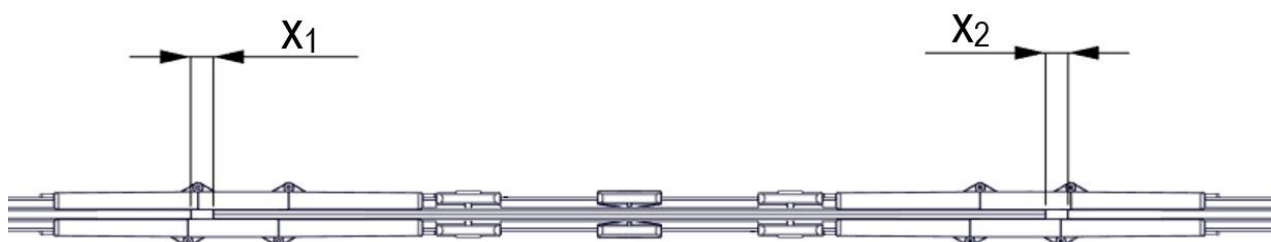
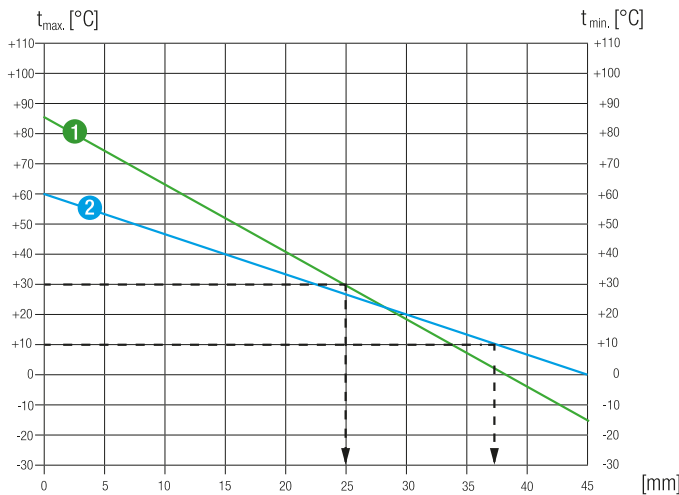

Fig. 91: Expansion gap in the expansion unit

## Insulated Conductor Rail System

### SinglePowerLine Program 0813



**Example:**

- 1.) Temperature range from -15°C to +85°C.  
 Ambient temperature during installation: +30°C  
 Air gap: 25 mm per expansion point  
 = 2 x 25 mm for the expansion unit
  
- 2.) Temperature range from 0°C to +60°C.  
 Ambient temperature during installation: +10°C  
 Air gap: 37 mm per expansion point  
 = 2 x 37 mm for the expansion unit

Fig. 92: Example of how to read the setting dimension

$t_{min}$  = lowest temperature occurring in the given application

$t_{max}$  = highest possible operating temperature in the given application + current heating

Guide values for current heating:

Temperature	Duty cycle (DC)
10°C	40%
20°C	65%
30°C	100%

To determine the setting dimension on an individual basis, use the diagram template in Section 12.2

- Draw a connecting line from  $t_{min}$  to  $t_{max}$ .
- Draw a horizontal line from the ambient temperature during installation to the connecting line from  $t_{min}$  to  $t_{max}$ .
- In the diagram template, draw a vertical line downwards from the intersection of the two lines.
- Now read off the expansion gap to be installed and set it for  $x_1$  and  $x_2$ .
- Check the setting value, once the nearest anchor point on the route has been tightened.



Use the QR code ("click" or "scan") to see our animation **Mounting Expansion Elements and Adjusting Air Gap**

## Insulated Conductor Rail System

### SinglePowerLine Program 0813

---

#### 6.4.3.8 Mount air gap

Air gaps are used for galvanic isolation and segmentation of system sections and subdivide a conductor rail system into sections (e.g., maintenance lines that can be fed in and switched on separately). An air gap consists of two opposing end caps. For each isolation point, two air gaps are mounted at a suitable distance to avoid voltage leak across the double current collector.

#### Requirements:

The ends of the conductor rail ends are deburred (see Fig. 46) and not connected with a connector.



Please refer to the project-specific documents for the exact position of an air gap.

#### Required tools:

- Rubber mallet
- Torque wrench with a measuring range from 5 Nm to 50 Nm and sockets SW 5, SW 8, SW 10, SW 17

#### Work steps:

- Slide the hanger clamp (Pos. 1), anchor clamp (Pos. 2) and end cap onto the end of the rail (see Fig. 93). Do not yet tighten the screws on the side of the anchor clamp.

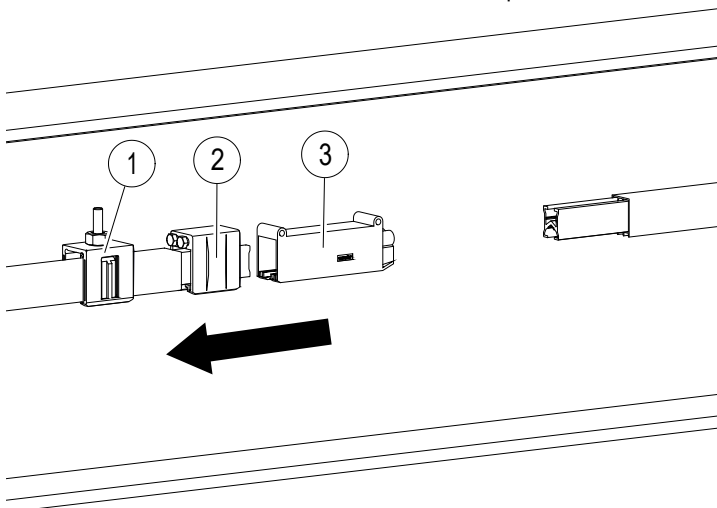

Fig. 93: Slide the hanger clamp, anchor clamp and end cap onto the end of the rail

- Mount end cap (Pos. 3) (see Section 6.4.3.9)
- Slide the hanger clamp and anchor clamp onto the second end of the rail and mount the end cap (see Fig. 94).

## Insulated Conductor Rail System

### SinglePowerLine Program 0813

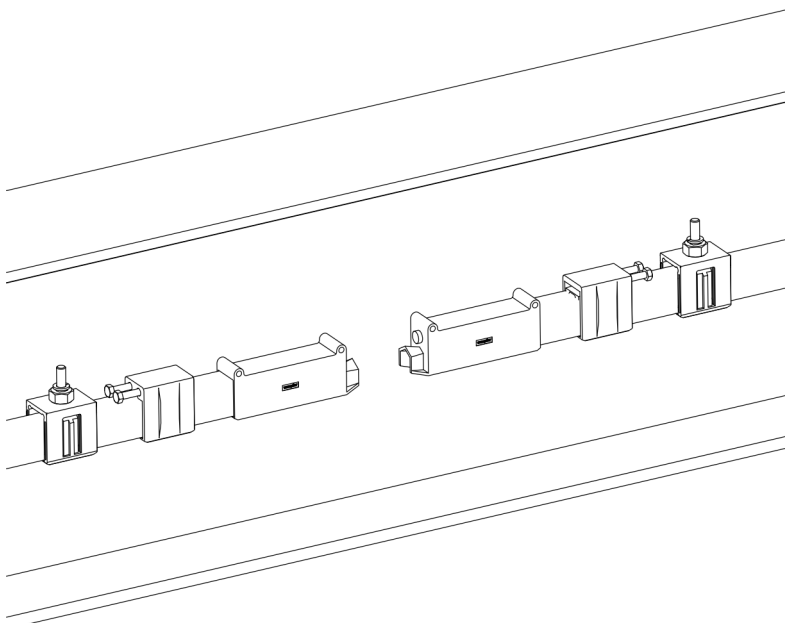

Fig. 94: The hanger clamp, anchor clamp and end cap are mounted on both rail ends

- Mount the plate for the air gap (Pos. 4) with fastening elements, consisting of hexagon screw DIN931-M6x50 (Pos. 5) (8 Nm) and lock nut DIN985 (Pos. 6), on the end caps (see Fig. 93) and tighten with the specified torque (SW 10, torque wrench: **8 Nm**). (see Fig. 95). Slide the hanger clamp onto the anchor clamp.

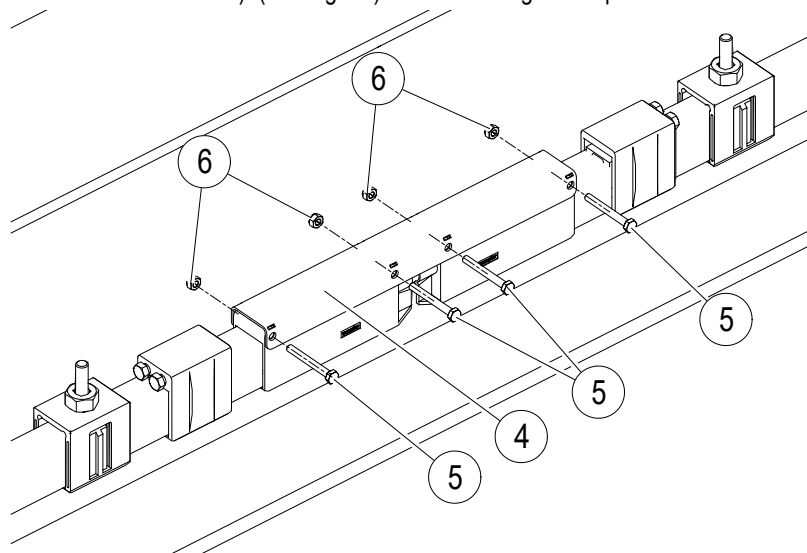

Fig. 95: Mount the plate for the air gap

- Slide the anchor clamp (Pos. 2) against the end caps and tighten the side screws of the anchor clamp (Pos. 8) (see Fig. 96). Slide the hanger clamp (Pos. 1) up to the screw head of the screw on the side of the anchor clamp (see Fig. 97).

Insulated Conductor Rail System

SinglePowerLine Program 0813

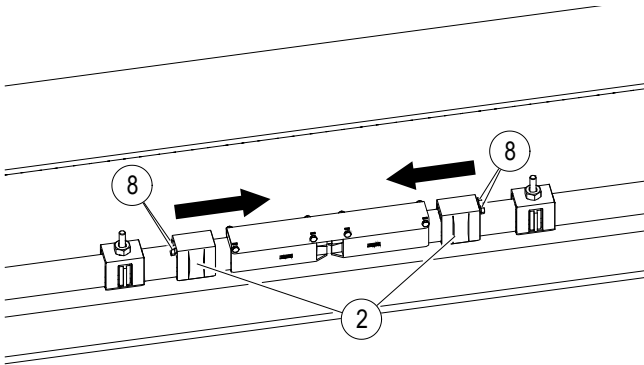

Fig. 96: Slide the anchor clamp to the air gap and tighten the side screws

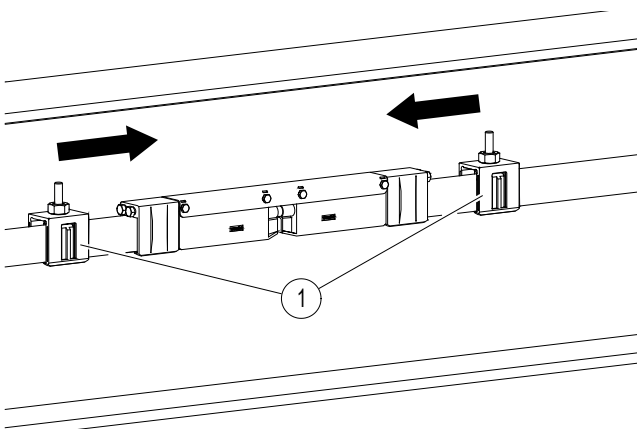

Fig. 97: Slide the hanger clamp up to the screw on the side of the anchor clamp

- Place the bridging plate (Pos. 9) over the bolts of the hanger clamp and screw together with the M10 nuts (Pos. 13) with the specified torque (SW 17, torque wrench: **14 Nm**). Mount the cover (Pos. 14) onto the hanger clamp using the fastening elements, consisting of washer DIN 9021 (Pos. 12), washer DIN 125 (Pos. 11) and hexagon M10 nut (Pos. 13) and tighten with the specified torque (SW 17, torque wrench: **8 Nm**). In addition, secure the hexagon M10 nut (Pos. 10) with Loctite (see Fig. 98).

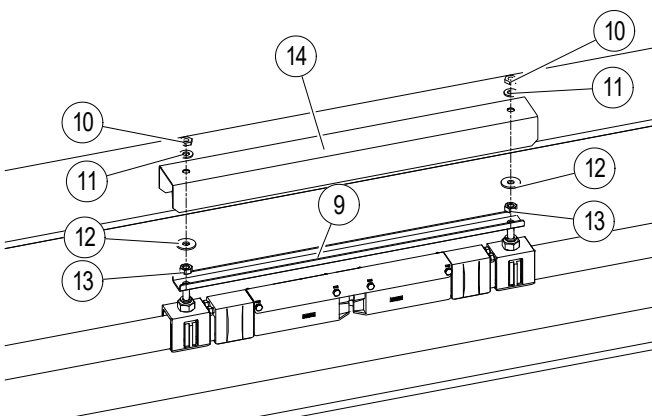

Fig. 98: Mount the bridging plate

- Mount all air gaps in the same way.

## Insulated Conductor Rail System

### SinglePowerLine Program 0813

---

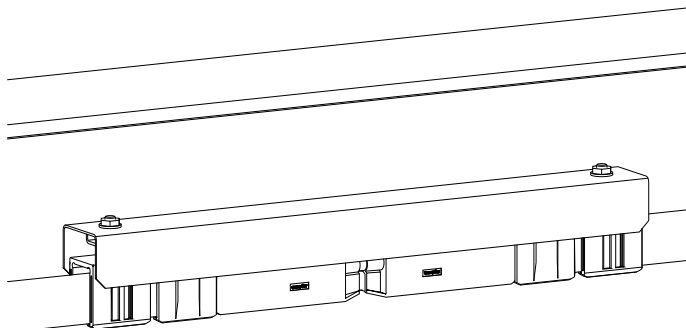

Fig. 99: Mounted air gap 0813



#### NOTE!

A potential difference in the two conductor rails in the air gap can lead to spark formation and electrical erosion in the rail during a current collector transfer.  
For this reason, avoid potential constructive differences!



Use the QR code ("click" or "scan") to see our animation **Mounting the Air Gap Insulation Section**

#### 6.4.3.9 Mount end caps

##### Required tools:

- Hexagon wrench SW5
- Torx Screwdriver set, TX25
- Rubber mallet

End caps serve as a termination and for protection against accidental contact with a free rail end.

##### Requirement:

The outer edges of the conductor rail must be deburred (see Fig. 46).

##### Distances:

End cap end to hanger clamp center: Min. 250 mm (up to 400 mm)

## Insulated Conductor Rail System

### SinglePowerLine Program 0813

---

#### Work steps:

→ Insert the expansion dowel (Pos. 3) into end cap (Pos. 1) (see Fig. 100).



**NOTE!**

With a Conductor Rail System 1000 A, the expansion dowel is not required.

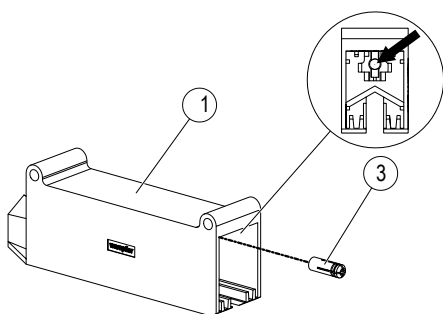

Fig. 100: Insert expansion dowel into end cap

→ Lightly tap the end cap (Pos. 1) onto the conductor rail end with careful and light mallet taps (Pos. 2) (see Fig. 101 and Fig. 102).

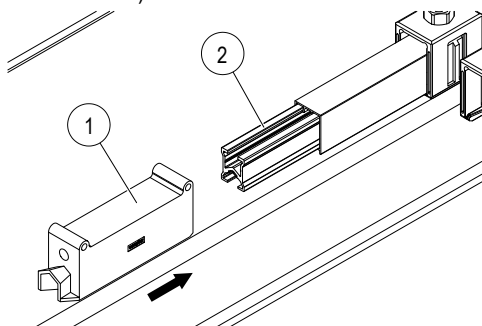

Fig. 101: End cap on conductor rail end

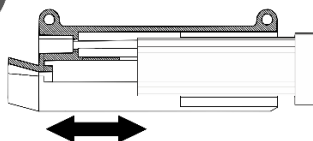
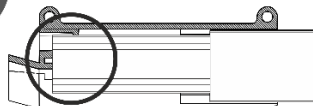

Fig. 102: The end cap is mounted correctly (above) and incorrectly (below)

## Insulated Conductor Rail System

### SinglePowerLine Program 0813

→ Tighten the cylinder head screw (Pos. 4) DIN912-M6x35 with 3 Nm (see Fig. 103).



#### NOTE!

With Conductor Rail System 1000 A, the end cap is secured with two thread-forming raised countersunk screws (Pos. 4), Torx drive, and tightened to 1.5 Nm (see Fig. 104).

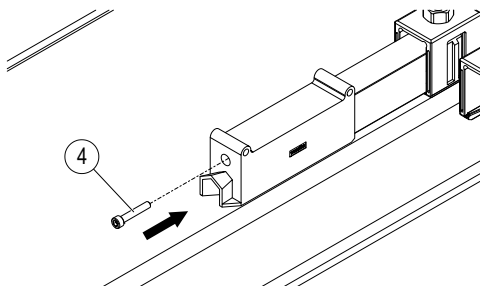

Fig. 103: Tighten cylinder head screw

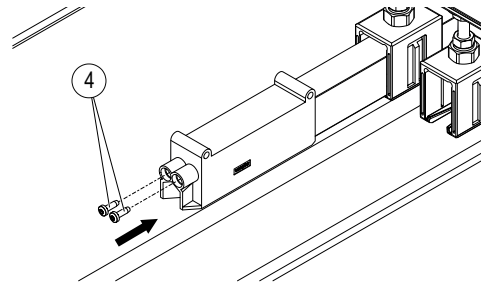

Fig. 104: Tighten raised countersunk screws

→ Insert the lamellar plug (Pos. 5) into the hole (see Fig. 105).

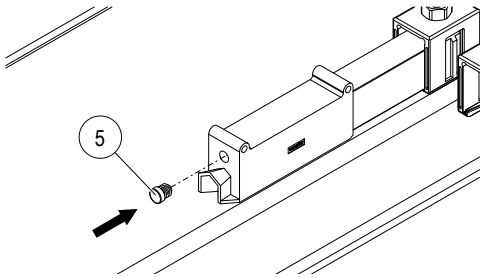

Fig. 105: Insert lamella plugs over cylinder head or raised countersunk screws

→ Mount each end cap in the same way (see Fig. 106).

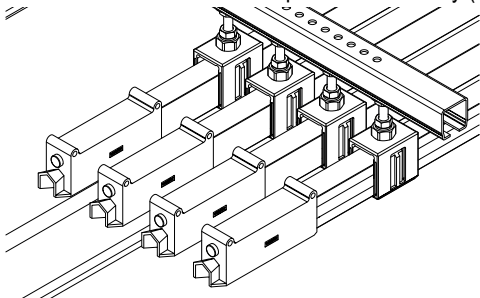

Fig. 106: All end caps are mounted



Use the QR code ("click" or "scan") to see our animation: **Mount end cap.**

## Insulated Conductor Rail System

### SinglePowerLine Program 0813

#### 6.4.3.10 Mount pickup guide

For areas in which it is necessary to travel in or out of the conductor rail system, pickup guides are used in combination with the current collectors provided for this purpose. It should be noted that the maximum speed at pickup guides is 80 m/min, and pickup guides are classified as wear parts. The installation tolerances must be observed. Simultaneous offsets with the maximum tolerances in the x- and y-directions are not permitted.

The pickup guide centers the current collector with a maximum lateral and vertical offset of  $\pm 25$  mm (settings of less than  $\pm 10$  mm are recommended).



**NOTE!**

For systems with pickup guides, there must be an appropriate number of current collectors installed at an interval that ensures that the minimum number of current collectors required for the current demand is always engaged. (see Fig. 108 below).



**WARNING!**

#### De-energize current collectors or protect them against contact!

The user must ensure that current collectors located between the pickup guides are de-energized or protected against accidental contact.

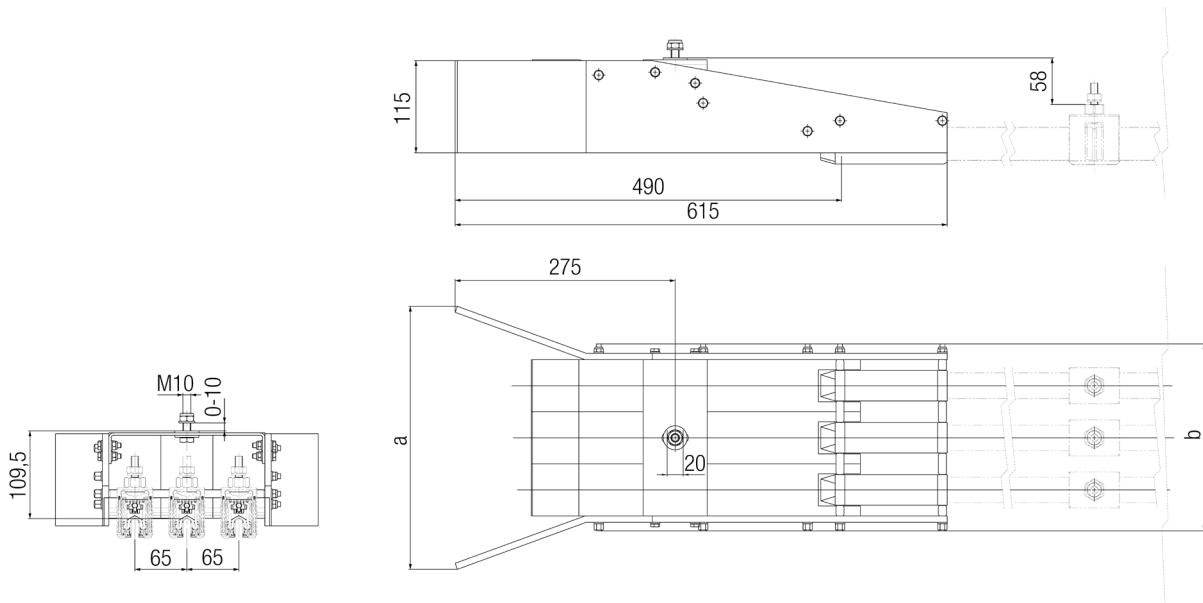

Fig. 107: Installation dimensions of the pickup guide

Dimension [mm]	Number of poles				
	1	2	3	4	5
<b>a</b>	200	265	330	395	460
<b>b</b>	105	170	235	300	365

## Insulated Conductor Rail System

### SinglePowerLine Program 0813

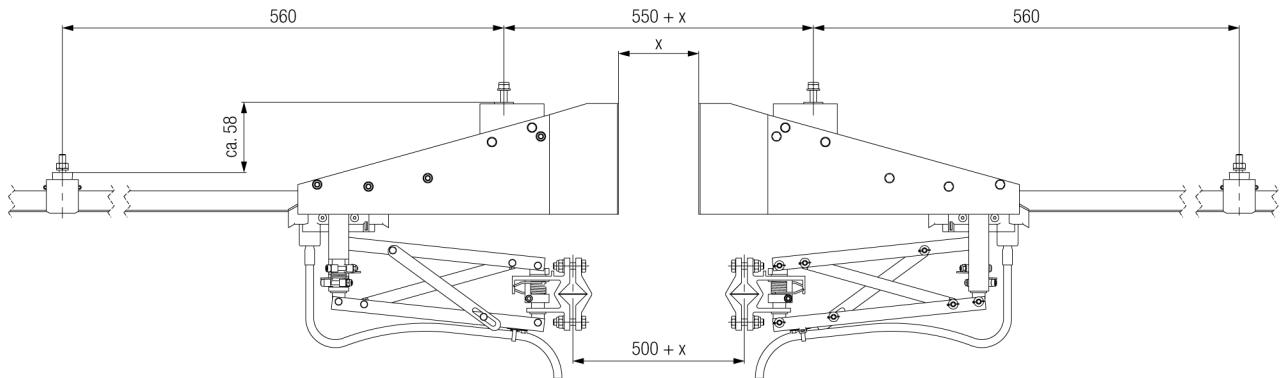

Fig. 108: Important dimensions for systems with pickup guides



**NOTE!**

Please also note the information on installing the PE current collector for systems with a pickup guide (see Section 6.4.4).

## Insulated Conductor Rail System

### SinglePowerLine Program 0813

#### Hanger clamp distance for systems with pickup guides:

When using multiple pole pickup guides, the distance between phases must be reduced from 80 mm (Standard) to 65 mm on the section shortly before the pickup guide. For this purpose, the 2 to 3 hanger clamps are mounted in front of the pickup guide with a distance of 65 mm (see Fig. 109).

#### Anchor clamps for systems with pickup guides:

Anchor clamps must be mounted on each rail to the right and left of the first hanger clamp after the pickup guide (see Fig. 109 and Section 6.4.3.5).

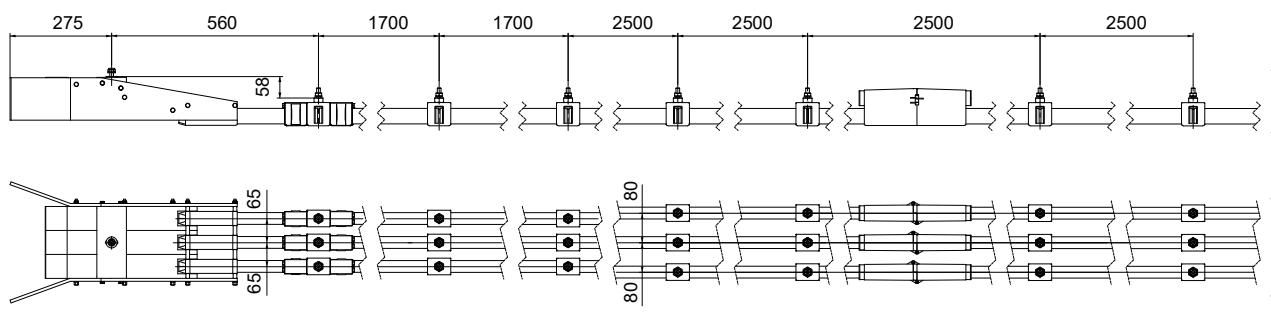

Fig. 109: System layout for systems with pickup guides

#### Requirements:

The phase offset of the hanger clamps in front of the pickup guide was reduced from 80 mm to 65 mm.

#### Distances:

Pickup guide to the first hanger clamp: 560 mm

#### Required tools:

- Rubber mallet

#### Work steps:

- The pickup guide is delivered complete with end caps. Push the end caps onto the rails as far as they will go with light mallet taps.



**NOTE!**

- Observe the reduced distance between phases near the guide area.
- Use double current collectors with stroke limitation and centering for the guide paths.
- Remove PE deflector for funnel applications (use drilling template for PE protection against interchanging).
- Disconnect the power to the current collector near the transfer and provide on-site measures for shock protection, such as mounting height, covers, etc.

## Insulated Conductor Rail System

### SinglePowerLine Program 0813

#### 6.4.4 Mount current collector

There are two types of current collector mounting:

- Single current collector 250 A
- Double current collector 500 A

In addition, there are variants for insertion from below, from the side (see Section 6.4.4.1), variants for higher speeds and current collectors suitable for guide travel.

In order to mount the current collector onto the mobile consumer, it is mounted on a towing arm by means of a square support on the current collector.

The specified distance between the central axis of the towing arm and the contact surface must be maintained and it must be ensured that the central axis of the current collector is mounted exactly on the central axis of the conductor rail (see Fig. 112).



#### ATTENTION!

##### Always include redundancy for PE current collectors

For standard-compliant use (DIN EN 61140-2016-7.3.5.1 and DIN EN 60204-1-2018), Conductix-Wampler recommends always including a redundancy for PE current collectors.

Further measures must be taken depending on the applications and the results of the operator's risk assessment.

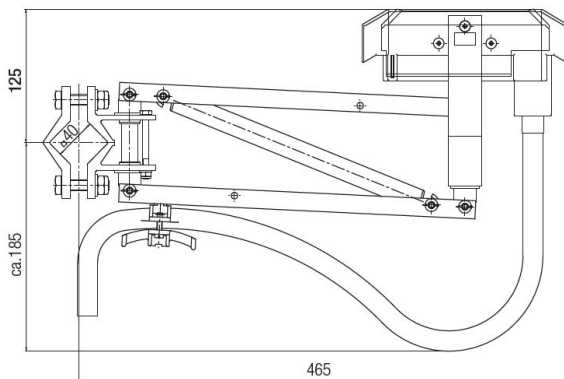

Fig. 110: Mounting dimensions of the single current collector 250 A

#### Single current collector (250 A)

##### Maximum current load:

250 A

##### Max. travel speed:

600 m/min; higher travel speeds on request

##### Contact pressure:

28 N

##### Lateral deflection:

± 100 mm

##### Working stroke in insertion direction:

± 40 mm

##### Connecting cable:

70 mm<sup>2</sup>, highly flexible, 1.5 m long (longer connecting cable on request)

##### Distance between the axis of the towing arm and the contact surface of the rail (nominal mounting dimension):

125 mm (see Fig. 112)

##### Temperature range cables:

-15 °C to + 55 °C (environment)

## Insulated Conductor Rail System SinglePowerLine Program 0813

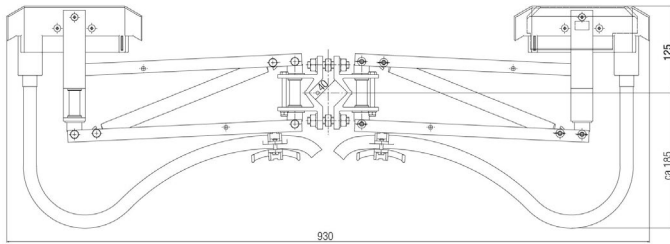

Fig. 111: Installation dimensions of the 500 A double current collector

### Double current collector (500 A)

**Maximum current load:**

500 A.

**Max. travel speed:**

600 m/min; higher travel speeds on request

**Contact pressure:**

2 x 28 N

**Lateral deflection:**

± 100 mm

**Working stroke in insertion direction:**

± 40 mm

**Connecting cable:**

70 mm<sup>2</sup>, 1.5 m long, highly flexible; longer connecting cable on request

**Distance between the axis of the towing arm and the contact surface of the rail (nominal mounting dimension):**

125 mm (see Fig. 112)

**Temperature range cables:**

-15 °C to + 55 °C (environment), different temperature requirements on request

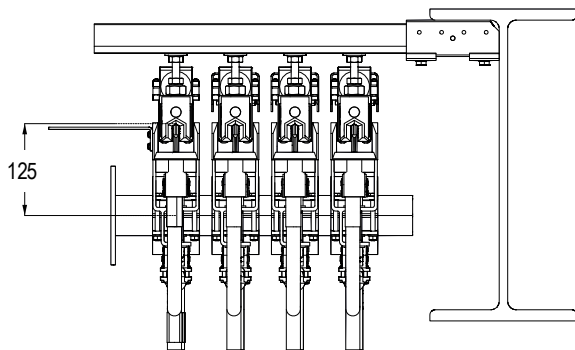

Fig. 112: Nominal mounting dimension 125 mm

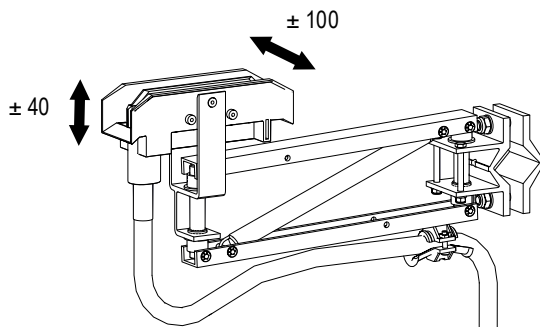

Fig. 113: Deviation of the current collector in mounted position with nominal mounting dimension 125 mm

## Insulated Conductor Rail System

### SinglePowerLine Program 0813

#### Instructions for mounting the current collector

- Lead the connecting cables straightly and with high flexibility in order to avoid deflection, pulling or pressing on the sliding contacts or movement restrictions of the current collector (see Fig. 114 to Fig. 120).
- Use only highly flexible and double-insulated (for voltages > 48 V) Conductix-Wampfler connecting cables! In the event of repairs, use a cable lug with shrink tubing for the flexible connecting cables (see Connection repair set, Order No.: 08-K154-0394).
- Do not bundle, fix or attach identification signs to the current collector connecting cable!
- Do not allow foreign objects to protrude into the moving range of the current collector and connecting cables!
- Choose foreign objects such as fastening screws in such a manner that the movement of cables and current collectors is not affected.
- In systems with curves, the ideal mounting position for the current collectors is directly at the height of the wheel contact point (in the pivot point or in the steering axis) of the guideways. When the positions and internal and external curves deviate too far, the distances to the rail and thus the contact pressure change. In the worst case, the sliding contacts and conductor rail can cause increased wear and tear to the point of damage to the system. Tolerances must be strictly maintained at the narrowest points.

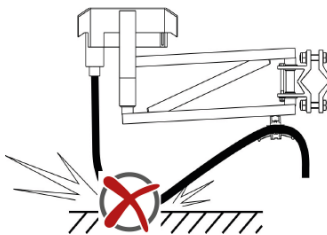

Fig. 114: The connecting cable must not be laying downward

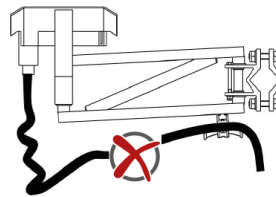

Fig. 115: Do not compress or kink the connecting cable

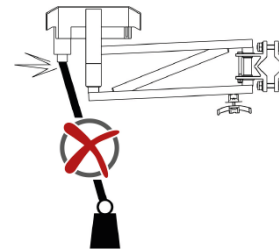

Fig. 116: Do not load the connecting cable

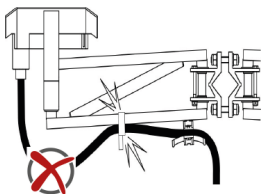

Fig. 117: Do not fix the connecting cable to the joint of the current collector with a cable tie

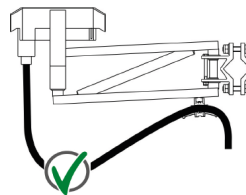

Fig. 118 Connecting cable laid correctly

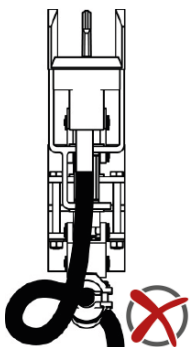

Fig. 119: Do not twist the connecting cable

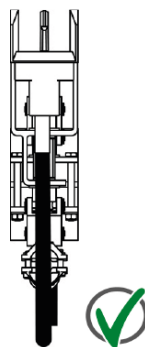

Fig. 120: Connecting cable is not twisted

## Insulated Conductor Rail System

### SinglePowerLine Program 0813

---

#### Requirements for mounting the current collectors

- Conductor rail is installed (see Section 6.4.3)
- Mobile unit (s) used in the guideway
- Towing arm (see Order No.: 020197-XXX) mounted on the mobile unit and aligned parallel to the poles of the conductor rail. If there are bends in the conductor rail, the towing arm should be installed in the pivot point or in the steering axis. Observe the current collector tolerances (mounting dimensions, check at the narrowest point in the case of curves). The towing arm must not have any play or bend.

#### Required tools:

- Torque wrench with a measuring range from 5 Nm to 50 Nm and socket SW 17

#### Work steps:

- The towing arm is mounted with four screws on the connecting flange to a suitable point of the vehicle. Observe the mounting dimensions provided above.
- Tension the towing arm (Pos. 1) in the middle support (square) (Pos. 3) of the current collector. At the same time, gradually tighten the outer M10 nuts (Pos. 2) in alternation with an SW 17 torque wrench (torque for galvanized: **30 Nm**, torque for stainless steel: **20 Nm**) (see Fig. 121). Pay attention to the tolerances and instructions provided above.

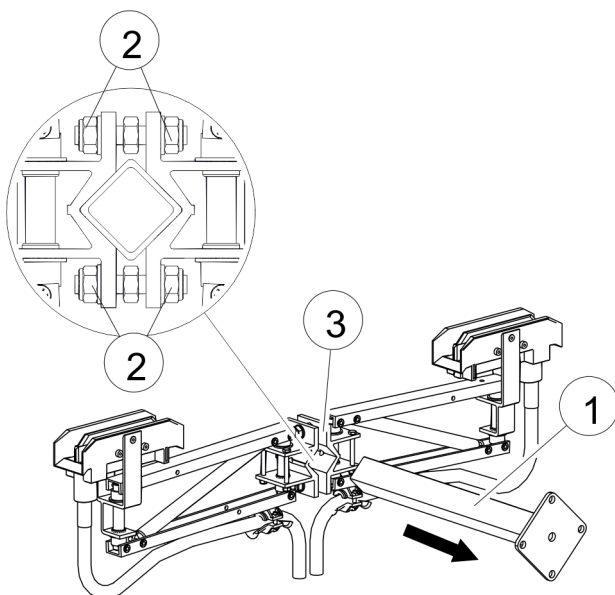

Fig. 121: Mount the towing arm



Use the QR code ("click" or "scan") to see our animation **Current Collector Tolerances**

## Insulated Conductor Rail System

### SinglePowerLine Program 0813

#### 6.4.4.1 Current collector insertion from the side

For current collector insertion from the side: The spacer ensures that the current collector remains in its neutral position. (see Pos. D in Fig. 122)

When the current collector is inserted from the side, the spacer must always be seated at the bottom!

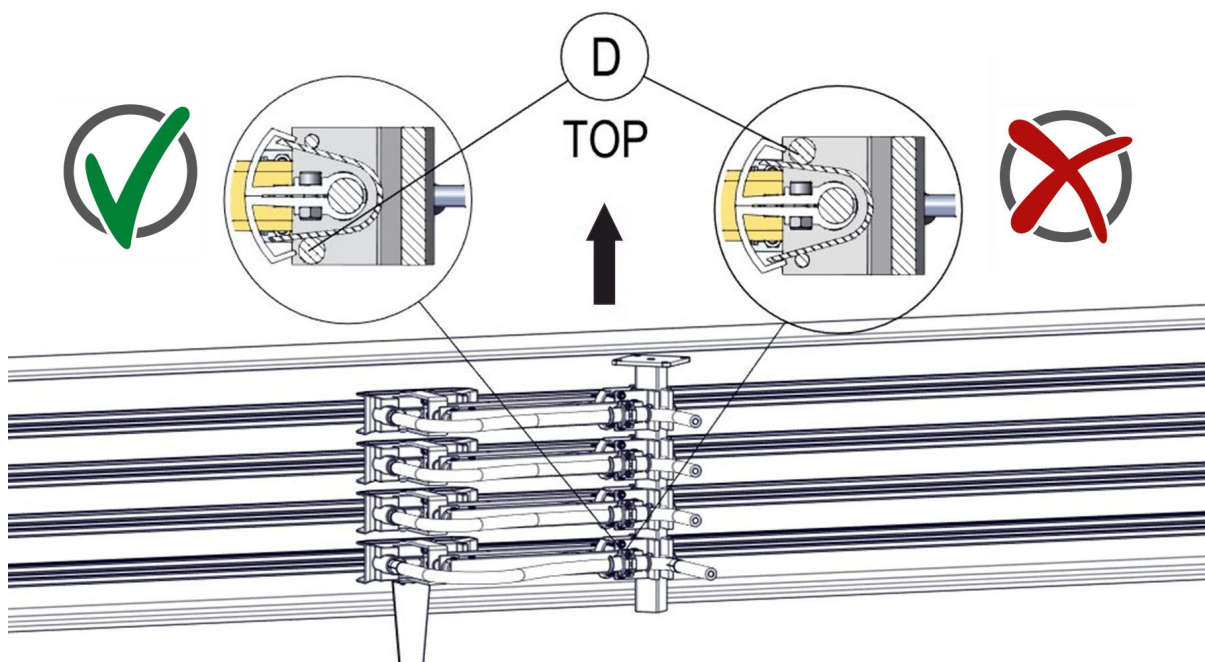

Fig. 122: Spacer (Pos. D) is seated on the bottom

#### 6.4.4.2 Typical mounting errors

- Rail joints and transfers have not been deburred.
- Distance within connectors was not maintained (on end with Alu/CopperECO, from 2 to max. 3 mm with copper)
- Pickup guides are not set correctly (end positions, dimensional tolerances).
- Incorrect current collector connecting cables were used.
- Connecting cables are not used according to the specifications (not free of directional and tensile forces).
- Mounting positions are not within specifications. Permissible tolerances exceeded in bends and curves.
- When inserted from the side, the current collector spacer is on top or has not been installed. (see Pos. D in Fig. 122)

## Insulated Conductor Rail System

### SinglePowerLine Program 0813

---

## 6.5 Electrical installation

### 6.5.1 Conductor Rail

Pay attention to the selection of the connecting cable and a tension-free laying.

- Select cables with a suitable cross section.
- For phases, doubly insulated connecting cables must be provided for voltages > 48 V.
- At feed-in points that change their position when the system is subjected to a thermal expansion (not recommended!), the connecting cable must be laid with a flexible loop.
- The line feed is provided with on-site strain relief.

### 6.5.2 Current Collector

- Pay attention to the selection of the connecting cable and to a correct and tension-free laying of the connecting cables (see Fig. 114 to Fig. 120).
- Only use only highly flexible Conductix-Wampfler cables! In principle, connecting cables with copper wires are to be used.
- Use ferrules with insulation collars for the flexible connecting cables.
- For phases, doubly insulated connecting cables must be provided for voltages > 48 V.
- Do not bundle or fix the connecting cable of the current collector or provide it with identification labels!
- Do not allow foreign objects to protrude into the moving range of the current collector and connecting cables!

## 6.6 Further Documents



### Read and follow the additional instructions!

You can find further information on the installation of conductor rail systems in the following instructions:

- WV0800-0001 Cleaning of Conductor Rails
- WV0800-0002 Maintenance Schedule Conductor Rails
- MV0813-0010 Grounding and short-circuit device
- MV0813-0014 Disassembly Tool 0813
- MV0813-0015 Heating wire 0813
- MV0813-0016 Quick Guide Conductor Rail System 0813
- MV0800-0018 Insulation measurement of heating wires
- MV0800-0019 Insulation measurement of conductor rails

## Insulated Conductor Rail System

SinglePowerLine Program 0813

---

### 7 Commissioning

---

#### 7.1 Safety

##### Personnel:

- The conductor rail system must only be commissioned, as well as operated for the first time after a repair, by qualified electricians!
- The qualified electricians must meet the requirements described in Section 2.2.1.

##### Recommended protective equipment:



**WARNING!**

##### **Risk of injury due to improper commissioning!**

Improper commissioning can lead to dangerous situations for personnel (see Section 7.2.1).

- Before commissioning, conduct the inspections on the inspection list of the manufacturer.
- Measure the insulation resistance (see MV0800-0018 or MV0800-0019) each time before commissioning. Follow the locally applicable technical standards, directives, and legal regulations.
- Always ensure that all the installation work has been fully completed before each commissioning.
- Always ensure that all components have been properly installed before each commissioning.



**CAUTION!**

##### **Ensure a free travel path before beginning the commissioning!**



**CAUTION!**

##### **Contact problems or increased heating!**

- Clean the contact surface of the sliding contact before commissioning and remove soiling, oxidation, pitting corrosion and other impurities by means of a brass brush or abrasive paper (320 grit).
- Avoid standstill operation with high currents during commissioning as much as possible. The sliding contacts are not yet grounded and can therefore heat up more.

## Insulated Conductor Rail System

### SinglePowerLine Program 0813

---



**DANGER!**

#### **Risk of injury due to crushing of skin and limbs!**

There is a risk of crushing of skin and limbs due to:

- Do not stand directly below the conductor rail system.
- Do not enter the danger zones of the system during operation. The operator/system manufacturer must ensure that technical protective measures are taken (covers, protection through distance, control technology, etc.).
- Operation is only permitted in areas inaccessible to the public and out of manual reach. The danger zone must be enclosed by the customer or protection ensured by distance.



**DANGER!**

#### **Fire hazard due to overload or sparking!**

Fire hazards occur due to overloaded cables, electrical arcs, short circuits or sparking. Sparking can occur with poorly serviced, contaminated conductor rails or if the installation does not comply with the required tolerances.

Take the following measures:

- Before commissioning, ensure that all installation work has been completed and all the components have been properly installed.
- Conduct electrical testing as prescribed.
- Permissible current values must be observed.
- Maintain tolerances during operation.
- Carry out dimensioning according to permissible system load capacity and provide for appropriate electrical protective devices!
- Do not remove the prescribed electrical safety devices and protective devices.
- Do not store easily ignited materials near conductor rails.
- Check, service and clean conductor rails regularly and as prescribed. See Section 12.



**DANGER!**

#### **Risk of injury due to ensnarement or impact!**

An ensnarement and/or impact with moving conductor rails (slip ring) or current collectors connected to the machine and other components must be prevented.

- Cordon off the work area.
- Use caution when working in the vicinity of the danger zone, in particular if protective devices (covers, enclosures, control devices, etc.) have been removed or deactivated.
- Use caution when working in the vicinity of the danger zone, particularly below the conductor rail.
- Be aware of the risk of falling conductor rail system components if they have not been properly installed or if operated under inappropriate operating conditions (e.g., environment that contains solvents).
- Wear personal protective equipment!

## Insulated Conductor Rail System

### SinglePowerLine Program 0813

---



**DANGER!**

#### **Risk of injury due to impacts and punctures/stabs!**

Risk of injury due to impacts and punctures/stabs from sliding conductor rails due to holding packaging units at an angle, damaged packaging or carelessness with long goods/transport crates.

Risk of injury from impacts and punctures/stabs from falling conductor rails in areas with pedestrian traffic.

- Wear personal protective equipment!
- Cordon off the work area!
- Use caution when working in the vicinity, particularly below the conductor rail!
- Do not step under suspended loads!
- Before lifting, ensure that the packaging/transport crate is undamaged!



**WARNING!**

#### **Risk of injury due to punctures and stabs!**

Hazard due to moving or falling parts during maintenance/servicing.

- Wear personal protective equipment!
- Cordon off the work area!



**WARNING!**

#### **Risk of burns from hot surfaces!**

##### **Components can become hot during operation.**

- Operation is only permitted in areas inaccessible to the public and out of manual reach. The danger zone must be enclosed by the customer or protection ensured by distance!
- Protective devices are to be provided by the customer!
- Cordon off the work area!
- Use caution when working in the vicinity of the danger zone, particularly if protective devices (covers, enclosures, control devices) have been removed or are not activated!
- Wear personal protective equipment!



**CAUTION!**

#### **Before switching the system on!**

- Ensure that all installation work has been completed and all the components have been properly installed.
- Before each startup of the product or system, measure the insulation resistance (see MV0800-0019) according to locally applicable technical standards, directives, and legal regulations.
- Conduct electrical testing as locally prescribed.
- Ensure adequate stability on the product/system for the commissioning engineer.

### Insulated Conductor Rail System

#### SinglePowerLine Program 0813

---



**DANGER!**

**Risk of death due to electrical shock!**

Contact with components carrying electrical power can lead to death or severe injury due to electrical shock. Danger of injury due to shock reactions, falling or being thrown across the room due to electrical shock.

- Customer-side grounding of metallic components must be present.
- Customer-side protective devices must be present.
- Ensure secure footing!
- Wear personal protective equipment!

## Insulated Conductor Rail System

### SinglePowerLine Program 0813

## 7.2 Testing and initial commissioning

### 7.2.1 Test list

Test	Tested
Has the correct installation height been observed (see Section 3)?	
Are all installed components clean, dry and undamaged?	
Are the end caps available at the beginning and end of conductor rail and mounted as described in Section 6.4.3.9?	
Are all hanger clamps mounted according to Section 6.4.3.1?	
Are the conductor rails mounted according to Section 6.4.3.2?	
Are the rails connected according to Section 6.4.3.3?	
Are the anchor clamps mounted according to Section 6.4.3.4?	
The expansion gap was determined and set in accordance with Section 6.4.3.6. The sum of expansion gaps $x_1$ and $x_2$ on the expansion unit must equal twice the diagram value.	
Are the expansion units mounted according to Section 6.4.3.7?	
Are the air gaps mounted according to Section 6.4.3.8?	
Are the line feeds mounted according to Section 6.4.3.4?	
Are the pickup guides mounted according to Section 6.4.3.10?	
Are the current collectors mounted according to Section 6.4.4?	
Are the rail ends at the connection points and the end caps deburred and correctly aligned?	
Is the operating area tidy (no parts or tools)?	
Have the operating personnel been trained?	
Have the "Electric Flash" symbol and the name plate been affixed in a suitable location by the manufacturer?	
The phase offset is 80 mm or 70 mm (see Section 6.4.3.1)?	
Has the phase offset of the 2-3 hanger clamps in front of a pickup guide (if present) been reduced to 65 mm (see Section 6.4.3.10)?	
Have the hanger clamps been mounted at the correct distance of 2500 mm (see Section 6.4.3.1)?	
Has the distance of 1750 mm from hanger clamp to hanger clamp on the first and last track section (5 m) and 250 mm to the end cap (see Section 6.4.3.4) been maintained?	
Are the insulating profiles correctly engaged in all hanger clamps (see Section 6.4.3.2 and Fig. 60 and Fig. 61)?	
Have the specified installation clearances of the current collectors been observed (see Section 6.4.4)?	
Have the contact surfaces of the sliding contacts been cleaned before commissioning and soiling, oxidation, pitting corrosion and other impurities removed by means of a brass brush or abrasive paper (320 grit)?	
Are the current collector connecting cables installed without directional and tensile forces? The connecting cables must not pull on, press against or cause the current collectors to twist (see Fig. 114 - Fig. 120).	
All poles of the conductor rail system have been run through with a loose current collector? The current collector must not stick and must slide in the rail without hindrance.	
Are all electrical protection devices installed, tested and functioning?	

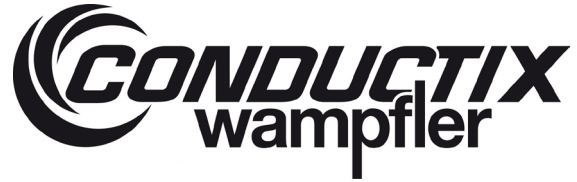

**Insulated Conductor Rail System**

**SinglePowerLine Program 0813**

Test	Tested
Are the connecting cables dimensioned according to the loads and the ambient/laying conditions?	
Are covers and barriers in place?	
Is the line feed properly connected?	
Are all metallic components (e.g., support structure/substructure) properly grounded?	
Has the insulation resistance* of the conductor rail system been measured according to local technical standards, directives, and legal regulations?	
Have the prescribed national electrical tests been conducted (e.g., measurement of the loop impedance)?	

\* **Note:** Insulation resistance test according to EN 60204-1: 2018  $\geq 1 \text{ M}\Omega$  with measuring voltage 500 VDC. Exception for conductor bars, conductor rails and slip rings  $\geq 50 \text{ k}\Omega$  (EN 60204-1/18.3: 2018)

**For systems with heating:**

Test	Tested
Has the heating wire (if present) been connected according to the project-specific documents and the installation instructions (MV0813-0015)?	
The inner and outer edges of the conductor rail were checked for burrs after the conductor rail was shortened? Particularly where the heating wire is located, care must be taken to ensure that there are no burrs so that the insulation of the heating wire is not damaged.	
In the case of shortened rails, the chamfer was created on the stainless steel strip and the cut surfaces deburred.	
The crimping point is properly laid under the insulating profile according to the installation instructions (MV0813-0015).	
An insulation measurement between the heating wire and the conductor rail was conducted (see MV0800-0018).	

.....  
Date

.....  
Signature

### Insulated Conductor Rail System

#### SinglePowerLine Program 0813

---

##### 7.2.2 Initial commissioning of the conductor rail system

- Conduct a complete run along the conductor rail (walking pace).



#### NOTE!

**The current collectors must not become caught, stick or scrape!**

Where necessary, repair any faults and conduct settings work.

After initial commissioning, a further review must be conducted to detect any damage or problems in the system.

##### **Visual inspection of the product/system after initial commissioning:**

- Current collector undamaged and without signs of heavy wear.
- Conductor rail components undamaged and in the proper location. No displacements or distortions. Check hanger clamps, end caps and fixed points in particular!
- Check that there are no visible signs of heavy wear (chips, plastic parts, etc.). Signs of heavy wear indicate that installation clearances and their tolerances are not being complied with. This can sometimes also be the case for individual sections of the route.

## Insulated Conductor Rail System

### SinglePowerLine Program 0813

---

## 8 Operation

---

Operating the conductor rail is limited to switching the voltage supply on and off when operation is interrupted, as described in Section 8.3.

The safety information in Section 8.1 must be observed to ensure safety during operation.

### 8.1 Safety



**DANGER!**

#### **Risk of death due to electrical shock!**

Contact with components carrying electrical power can lead to death or severe injury due to electrical shock. Danger of injury due to shock reactions, falling or being thrown across the room due to electrical shock.

The conductor rail must not be operated under the following circumstances:

- If the conductor rail is heavily soiled.
- If the conductor rail is wet.
- If parts under voltage are exposed (insulating profile or the insulation of the connecting cable are damaged).
- If the hanger clamp or insulation profile fail.
- If the conductor bar falls down and contacts a conductive material.

Take the following measures:

- Install the conductor rail in an area that is not accessible to the public outside and out of manual reach!
- Ensure proper electrical protection at all times!
- The danger zone must be enclosed by the customer or protection ensured by distance!
- Ensure customer-provided grounding of metallic components at all times.
- Ensuring the function of the customer's protective devices at all times.
- Check, maintain and clean the conductor rail regularly, and repair if necessary.



**DANGER!**

#### **Risk of injury due to cutting and amputation!**

Cutting on sharp edges must be avoided.

- Wear personal protective equipment!
- The operator/system manufacturer must ensure the technical protective measures are taken (covers, protection by distance, control technology, etc.)!
- Operation is only permitted in areas inaccessible to the public and out of manual reach! The danger zone must be enclosed by the customer or protection ensured by distance!

## Insulated Conductor Rail System

### SinglePowerLine Program 0813

---



#### **Risk of injury due to ensnarement, punctures/stabs and/or impacts!**

An ensnarement and/or impact with moving conductor rails (slip ring) or current collectors connected to the machine and other components must be prevented.

Risk of injury from impacts and punctures/stabs from falling conductor rails in areas with pedestrian traffic.

- Cordon off the work area!
- Do not enter the danger zones of the system during operation. The operator/system manufacturer must ensure the technical protective measures are taken (covers, protection by distance, control technology, etc.)!
- Operation is only permitted in areas inaccessible to the public and out of manual reach! Operation is only permitted in areas inaccessible to the public and out of manual reach!
- Use caution when working in the vicinity of the danger zone, particularly if protective devices (covers, enclosures, control devices, etc.) have been removed or disabled!
- Use caution when working in the vicinity of the danger zone, particularly below the conductor rail!
- With an installation height of 3 m or more in areas with pedestrian traffic, the conductor rails must be secured against falling!
- Beware of falling parts of the conductor rail system in the event of improper assembly or in unsuitable operating conditions (e.g., in an environment containing solvents)!
- Wear personal protective equipment!



#### **Unauthorized personnel are at risk!**

Unauthorized personnel are not familiar with the hazards in the working area.

- The system must only be operated by trained personnel!
- Keep unauthorized personnel away from the working area.
- In case of doubt, address such persons and direct them away from the working area.
- Stop working as long as unauthorized personnel are in the working area.

In order to comply with the **most important measures** for protection against hazards, the measures specified in Sections 2 and 3 must be observed. For information on foreseeable incorrect applications or unsuitable ambient conditions particularly see Sections 2.5 and 3.3.



#### **Risk of injury due to falling conductor rails!**

The hanger clamps of the conductor rail can fail and the conductor rail can fall down. Components can be damaged if the following or similar materials are stored in the vicinity of the conductor rail:

- Foodstuffs that contain aromatic compounds that can evaporate.
  - Coating products and paints.
  - Separating agents or coolants and lubricants.
  - See Section 3.3 and 2.8.4.
- Do not store any of the above or similar substances near the conductor rails.

## Insulated Conductor Rail System

### SinglePowerLine Program 0813

---



**DANGER!**

#### **Fire hazard due to overload or sparking!**

Fire hazards occur due to overloaded cables, electrical arcs, short circuits or sparking. Sparking can occur with poorly serviced, contaminated conductor rails or if the installation does not comply with the required tolerances.

Take the following measures:

- Conduct electrical testing as prescribed before commissioning.
- Before operation, ensure that the system has been properly commissioned!
- Permissible current values must be observed.
- Maintain tolerances during operation.
- Carry out dimensioning according to permissible system load capacity and provide for appropriate electrical protective devices!
- Do not remove the prescribed electrical safety devices and protective devices.
- Do not store easily ignited materials near to conductor rails.
- Check, service and clean conductor rails regularly and as prescribed. See Section 12.



**DANGER!**

#### **Risk of injury due to dust and abrasion!**

Breathing difficulties and eye irritation can occur due to thrown up dust and the abrasion of the carbon brushes/sliding contacts, copper conductor bars and plastic. There is a health hazard from respirable dust being thrown up. **Cancer, mucosa irritation and respiratory diseases** can be a consequence of frequent and prolonged stays in a heavily used facility without protective equipment.

#### **Observe the following measures:**

- Clean regularly! As needed and before starting the work, clean the conductor rail according to regulations (observe WV0800-0001). See Section 12.1.
- Prevent inhalation of dust from the conductor rail!
- Do not store or consume open food in the immediate vicinity of the conductor rail!
- See Section 2.8.3 for further information!



**WARNING!**

#### **Risk of burns from hot surfaces!**

#### **Components can become hot during operation.**

- Operation is only permitted in areas inaccessible to the public and out of manual reach. Operation is only permitted in areas inaccessible to the public and out of manual reach!
- Protective devices are to be provided by the customer!
- Cordon off the work area!
- Use caution when working in the vicinity of the danger zone, particularly if protective devices (covers, enclosures, control devices) have been removed or are not activated!
- Wear personal protective equipment!

## Insulated Conductor Rail System

### SinglePowerLine Program 0813

---

#### 8.2 Normal operation

The conductor rail system 0813 is protected against accidental contact and is suitable for use in non-publicly accessible areas, out of hands' reach in indoor and weather-protected outdoor areas, e.g., for ceiling cranes, process cranes or automatic passenger transport.

#### 8.3 Stopping the system



##### Risk of injury due to electrical shock!

- Switch off the power supply to the **conductor rail system** according to the 5 Safety Rules and secure it against switching on again. For the 5 Safety Rules, see Section 2.5.



#### 8.4 Continue operation



##### Risk of injury if safety equipment and protective devices are disabled!

- Before switching the system back on, ensure that all covers, safety systems and protective devices are installed and working properly.

##### Before switching the system back on, ensure that:

- The current collector heads are in contact with the conductor rail over their full length and the prescribed contact pressure is available.
- There is no coarse soiling or objects in the conductor rails.
  - Perform a visual inspection.
- The insulation resistance corresponds to the locally applicable technical directives:
  - As needed, before the device or system is started, measure the insulation resistance according to locally applicable technical standards, directives, and legal regulations.
    - Visual inspection of the product/system:
      - Current collector undamaged and without signs of heavy wear.
      - Conductor rail components undamaged and in the proper location. No displacements or distortions. Check hanger clamps, end caps and fixed points in particular!
      - Check that there are no visible signs of heavy wear (chips, plastic parts, etc.). Signs of heavy wear indicate that installation clearances and their tolerances are not complied with. This can sometimes also be the case for individual sections of the route.

## Insulated Conductor Rail System

SinglePowerLine Program 0813

---

### 9 Maintenance and Service

---

#### 9.1 Safety

Recommended protective equipment:



#### Risk of injury due to electrical shock!

- Switch off the power supply to the **conductor rail system** according to the 5 Safety Rules and secure it against switching on again. For the 5 Safety Rules, see Section 2.5.



#### Risk of death due to electrical shock!

Contact with components carrying electrical power can lead to death or severe injury due to electrical shock. Danger of injury due to shock reactions, falling or being thrown across the room due to electrical shock.

- Disconnect all line feeds from the voltage supply.  
The main power supply and heater voltage supply must be disconnected and secured against switching on again!
- Check whether a voltage is still present in the components and take measures where necessary.
- The customer must provide grounding for metallic components.
- The customer must provide protective devices.
- Conduct prescribed electrical testing!
- Observe the 5 Safety Rules (see Section 2.7)!
- Ensure secure footing!



#### Risk of injury due to improperly executed maintenance and/or servicing tasks!

Improper or omitted maintenance or servicing work can result in serious injury to persons and/or material damage. Loosely stacked components and tools that are left lying around are a source of danger. They are a trip hazards and improperly stored components can fall over or fall to the ground.

- The system must only be serviced and maintained by specialist personnel!
- Before starting work, ensure that there is sufficient space for the installation.
- Ensure the installation area is clean and tidy!
- If components have been removed, be careful to reinstall them properly, replace all fastening elements and comply with screw tightening torques.

## Insulated Conductor Rail System

### SinglePowerLine Program 0813

---



**CAUTION!**

#### **Risk of damage when cleaning the conductor rail!**

When cleaning, only loose or lightly adhering dust or foreign substances may be removed.

- **Do not use contact spray** (formation of silicon carbide/abrasive and/or damage of plastic parts).
- Use abrasives or brushes only partially as a tool to remove strong adhesions from light burn points. This work should only be conducted by qualified personnel.
- The lubricant layer on the guideway must not be removed, this will damage the rail (see also WV0800-0001 and WV0800-0004).



**DANGER!**

#### **Danger of injury due to dust and abrasion!**

Breathing difficulties and eye irritation can occur due to thrown up dust and abrasion of the carbon brushes/sliding contacts, copper conductor bars and plastic. There is a health hazard due to airborne respirable dust. Sensitization may occur if handling the conductor rail frequently and/or carelessly handling dust accumulation. **Cancer, mucous membrane irritation and respiratory diseases** can be a consequence of frequent and prolonged stays in a heavily used facility without protective equipment.

#### **Observe the following measures:**

- Clean regularly! Before starting work, clean the conductor rail according to regulations (follow WV0800-0001) See Section 12.1.
- Wear personal protective equipment.
  - Protective eyewear
  - Protective dust mask Class FFP3 (observe local regulations)
  - Protective gloves
  - Disposable coveralls
- Prevent contamination of the environment (e.g., people, goods, production facilities, etc.) while cleaning by taking appropriate measures (use covers, barriers, filter systems).
- Do not **blow out dust** with compressed air, but rather vacuum it away. The vacuum must be equipped with a Class HEPA H fine filter.
- Do not eat and/or drink while cleaning! Do not store or consume open food in the immediate vicinity!
- Do not smoke while cleaning!
- See Section 2.8.3 for further information.

## Insulated Conductor Rail System

### SinglePowerLine Program 0813

---



**DANGER!**

#### **Risk of injury due to ensnarement, punctures and stabs and/or impacts!**

An ensnarement, punctures and stabs and/or impact with moving conductor rails (slip ring) or current collectors connected to the machine and other components must be prevented.

Risk of injury due to impacts and punctures/stabs from the conductor rail sliding out when holding the rails at an angle, from carelessness with long goods or from falling conductor rails in areas with pedestrian traffic.

- Cordon off the work area!
- The main power supply (from the building) must be disconnected in the installation area and secured against switching on again!
- Use caution when working in the vicinity of the danger zone, in particular if protective devices (covers, enclosures, control devices, etc.) have been removed or deactivated.
- Wear personal protective equipment!



**WARNING!**

#### **Risk of injury due to impacts, puncture wounds and cuts!**

Hazard due to moving or falling parts during maintenance/servicing.

- Wear personal protective equipment!
- Cordon off the work area!
- Use caution when working in the vicinity of, and particularly below, the conductor rail.



**WARNING!**

#### **Fire hazard due to overload or sparking!**

A fire hazard can occur due to overloads of the cable, electrical arcing or short-circuits.

- Before recommissioning, ensure that all work has been completed and all components have been properly installed.
- Conduct electrical testing as prescribed.
- Permissible current values must be observed.
- Electrical fuses must be installed according to regulations.
- Warn against misuse.
- Do not store easily ignited materials near conductor rails.
- Dimensioning is according to permissible system load capacity and provide for appropriate electrical protective devices.

## Insulated Conductor Rail System

### SinglePowerLine Program 0813

---



**WARNING!**

#### **Risk of burns due to hot surfaces!**

Components can become hot during operation.

- Operation is only permitted in areas inaccessible to the public and out of manual reach! The danger zone must be enclosed by the customer or protection ensured by distance.
- Protective devices are to be provided by the customer!
- Cordon off the work area!
- Use caution when working in the vicinity of the danger zone, particularly if protective devices (covers, enclosures, control devices) have been removed or are not activated!
- Allow components to cool before servicing.
- Wear personal protective equipment!



**CAUTION!**

#### **The functioning and availability of the conductor rail system are dependent on the quality of the contact surface!**

Copper conductor rails are dependent on a lubricant-patina guideway that builds up during operation and should not be removed (no sanding or brushing off). Observe the Maintenance Instruction WV0800-0004!



**DANGER!**

#### **Risk of explosion!**

Airborne dust, open flames or other sources of ignition can result in explosion.

### Conducting maintenance work on the current collectors



**DANGER!**

#### **Risk of injury due to crushing of skin and limbs!**

There is a risk of crushing of skin and limbs due to:

- Current collector (spring force) during preassembly, installation, disassembly and maintenance
- Only permit trained technicians to conduct the work.
- Wear personal protective equipment!
- When changing the sliding contact, follow the separate instructions for this task. See Section 12.1.

### Replacing conductor rails



**DANGER!**

#### **Risk of injury due to cutting and amputation!**

The ends of the conductor bars can have sharp edges, particularly if they were cut to size on site and have not been deburred.

- Wear protective gloves and protective shoes.
- During assembly: Carefully deburr the insulation profile and conductor bars after sawing.
- Sawed through, disassembled conductor rails must be handled carefully and properly stored (container or transport box).
- Be mindful of sharp edges in the surroundings of the installation area and avoid contact.

## Insulated Conductor Rail System

### SinglePowerLine Program 0813

---

#### 9.2 Tools and materials

The maintenance work on the conductor rail must be conducted using commercially available metric tools.

Maintenance work	Tool
Measure the height of the sliding contacts	Calipers
Determine the contact pressure of the sliding contacts	Spring scale with a measuring range of 0 to 30 N

## Insulated Conductor Rail System

### SinglePowerLine Program 0813

### 9.3 Replacement of sliding contacts



**NOTE!**

Sliding contacts must be replaced in a timely manner before the minimum wear height is reached. The minimum wear height ( $h_{min}$ ) can be found in the maintenance schedule for conductor rails (see Section 12.1).

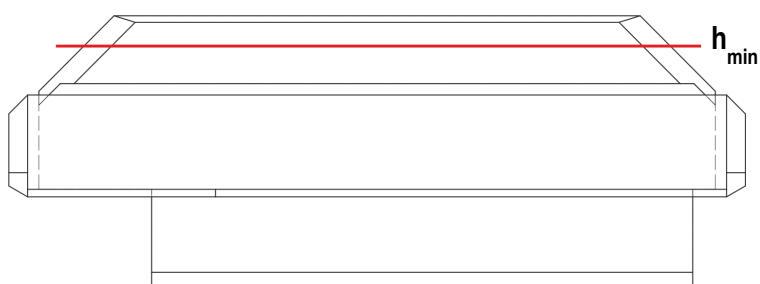

Fig. 123: Minimum wear height ( $h_{min}$ )

To replace the sliding contact (item 1) (see Fig. 125), the following steps must be carried out:

- Disconnect the complete system from the power supply. For this, also observe the notes in chapter 2.7.
- Pull the current collector down and turn it out from the side to be able to remove the current collector from the conductor rail (see Fig. 124). In case of more than three poles, the current collector may have to be dismantled from the towing device.

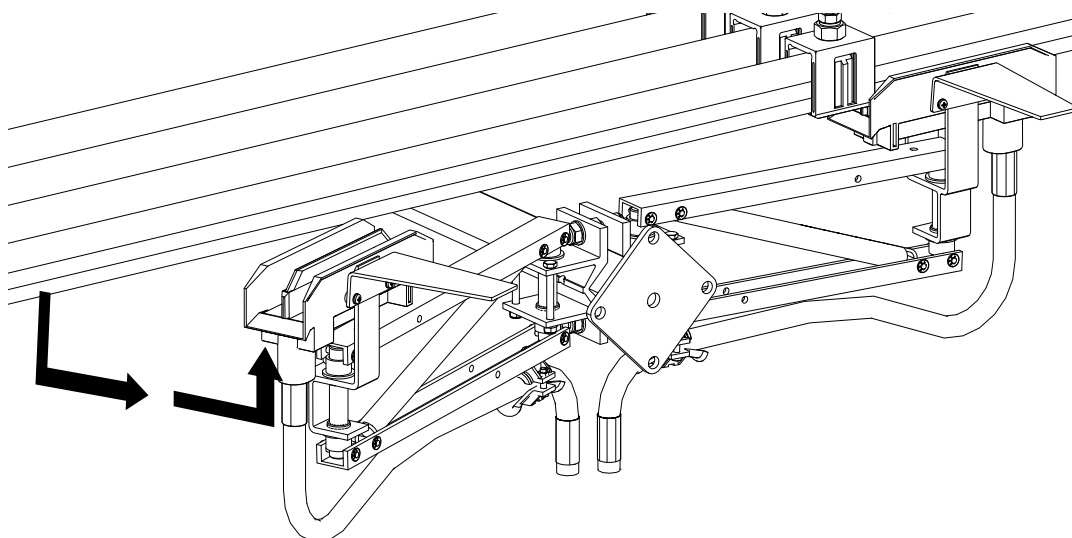

Fig. 124: Remove the current collector from the conductor rail

## Insulated Conductor Rail System

### SinglePowerLine Program 0813

- It is best to clean the current collector head with oil-free compressed air (wear a mask while doing this). If oil-free compressed air is not available, a cloth and a suitable detergent that does not attack the plastic must be used for cleaning.
- Hold the current collector head and pull out the sliding contact (item 1) with its plastic insulator (item 2) using water pump pliers. Start pulling out on the widest side (= side A in Fig. 126) of the contact sheet (item 3) (see Fig. 125 and Fig. 126).

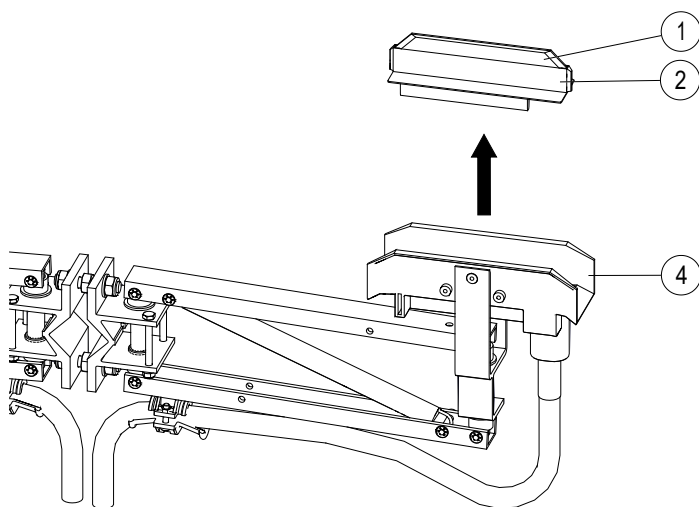

Fig. 125: Remove sliding contact (item 1) and plastic insulator (item 2)

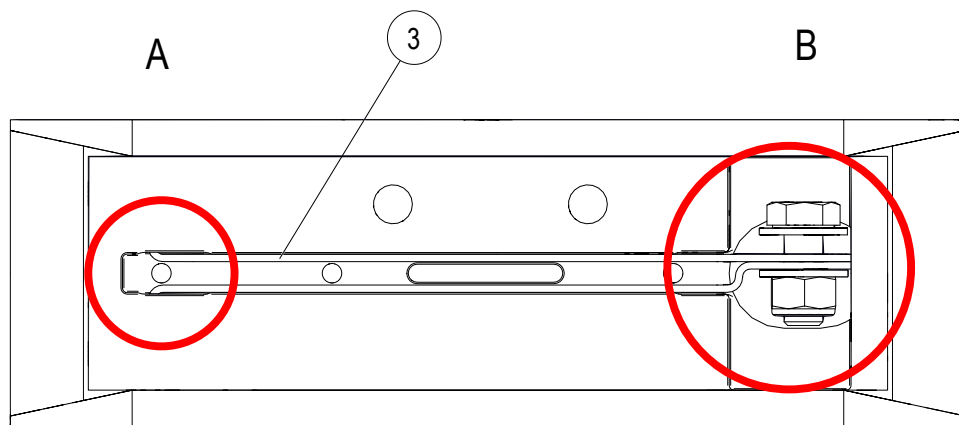

Fig. 126: Widest side (A) and narrowest side (B) of the contact sheet (item 3)

- Clean the area under the plastic insulator (item 2), especially the contact surface of the contact sheet (item 3) (see Fig. 126).

## Insulated Conductor Rail System

### SinglePowerLine Program 0813

→ Manually press the new sliding contact with its plastic insulator into the sliding contact insulation (item 4) (see Fig. 127). Start at the widest side of the contact sheet (side A in Fig. 126) and then insert the sliding contact completely while turning it. Do not use any tools (e. g. hammer) when pressing in, as this may damage the contact surfaces of the sliding contact. The following must be observed during insertion:

- The sliding contact recess (item 1) must be located on the side of the cable (side B) (see Fig. 127).
- The sliding contact (item 1) must be inserted between the contact sheet (item 3) and must not be positioned next to the contact sheet (see Fig. 128).

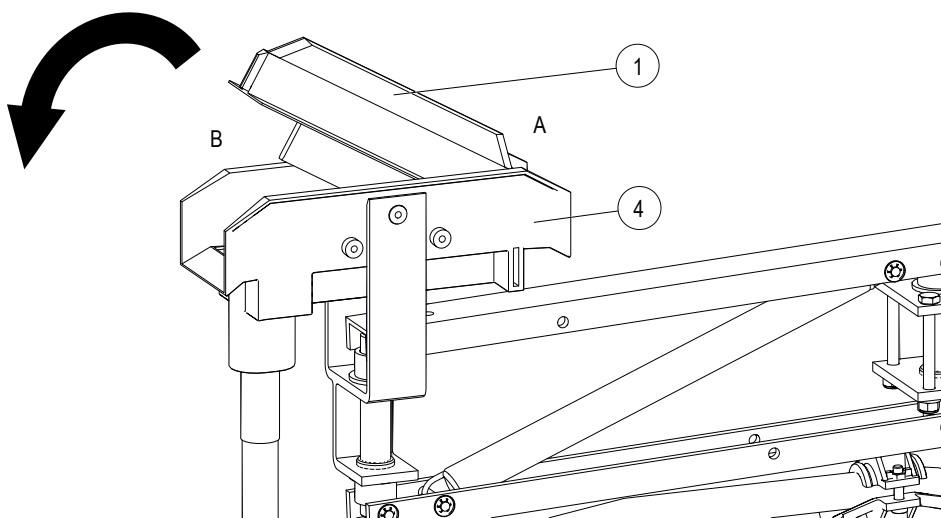

Fig. 127: Sliding contact recess on the side of the cable

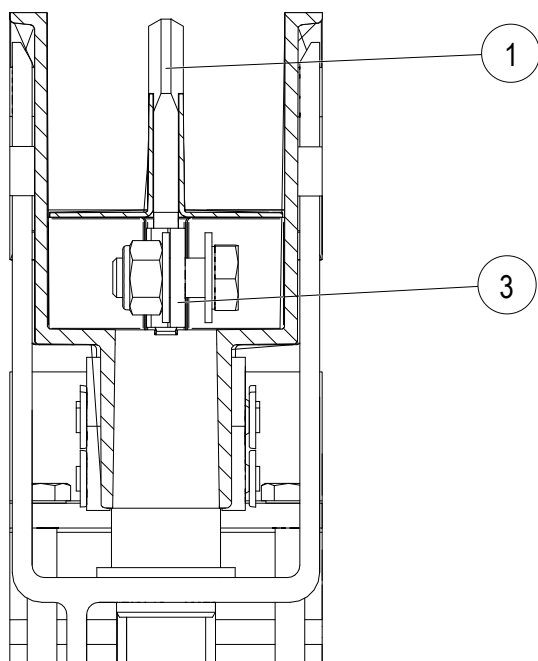

Fig. 128: Sliding contact (item 1) is positioned in the contact sheet (item 3)

## Insulated Conductor Rail System SinglePowerLine Program 0813

→ Reinsert the current collector into the conductor rail (see Fig. 129).

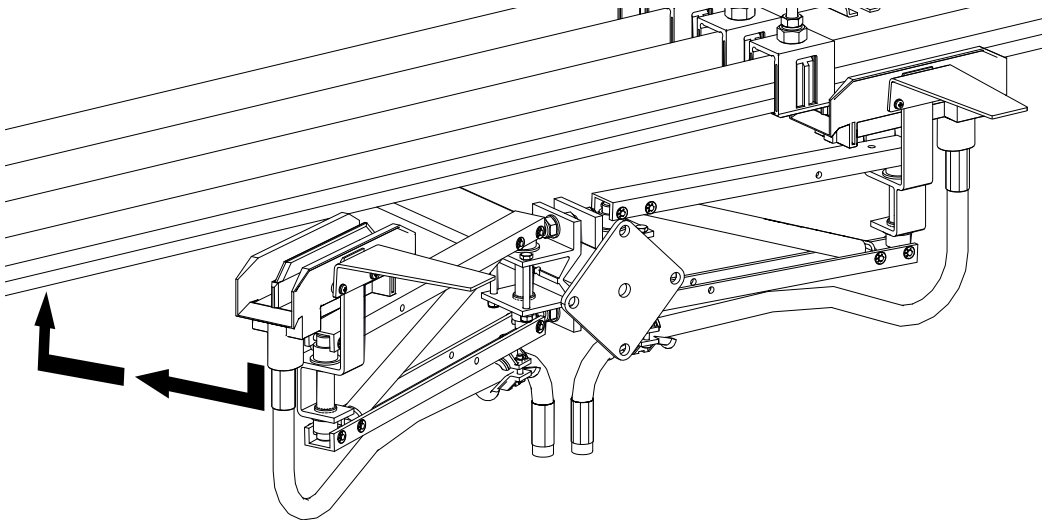
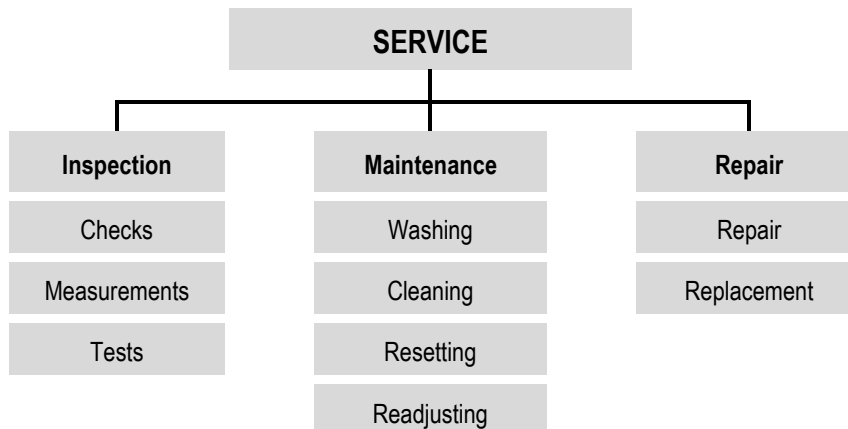

Fig. 129: Insert current collector into the conductor rail

### 9.4 Maintenance plan

The following tasks fall under the "Service" category:



The separate Maintenance Instruction WV0800-0002 contains the measures required for optimal and trouble-free operation. It also contains the required maintenance intervals.

The tasks specified and conducted as per the maintenance plan must be logged.

If regular checks reveal increased wear, the required maintenance intervals should be shortened according to the actual signs of wear.

Contact the manufacturer in case of any questions regarding maintenance tasks and intervals; see the service address on the last page. The operator must take responsibility for organizing the following maintenance measures to comply with warranty requirements and for general prevention of damage.

→ Inspection, maintenance and repair measures must only be conducted by trained, qualified technicians!

## Insulated Conductor Rail System

### SinglePowerLine Program 0813

---

- Inspection, maintenance and repair measures must always be documented!
- It is essential to observe the safety instructions in Section 9.1!

#### **Performance of the maintenance work**

- All maintenance work must be conducted according to the separate Maintenance Instruction WV0800-0002!
- Maintenance intervals must be observed.
- The maintenance work must be documented.

## Insulated Conductor Rail System

SinglePowerLine Program 0813

---

### 10 Troubleshooting

---

#### 10.1 Safety

Wear recommended protective equipment:



**WARNING!**

#### **Danger of injury due to improper troubleshooting!**

Improper troubleshooting can result in serious injury to person and property.

- Contact the manufacturer in case of malfunction.
- Allow troubleshooting to be conducted only by personnel from or authorized by the manufacturer.

The faults that, to Conductix-Wampfler's best knowledge, tend to arise are listed in the following table (see Section 10.2) together with their corresponding corrective measures.



**CAUTION!**

#### **Before working on these components!**

- Switch off the power supply to the **conductor rail system** according to the 5 Safety Rules **and secure it against switching on again**. For the 5 Safety Rules, see Section 2.5.



**DANGER!**

#### **Risk of death due to electrical shock!**

Contact with components carrying electrical power can lead to death or severe injury due to electrical shock. Danger of injury due to shock reactions, falling or being thrown across the room due to electrical shock.

- Disconnect all line feeds from the voltage supply.
- When decommissioning, check whether a voltage is still present in the components and take measures where necessary.
- The hazard zone must be enclosed by the customer or protected through distance.
- The customer must provide grounding for metallic components.
- The customer must provide protective devices.
- Ensure that there is sufficient stability in the area.
- If a conductor rail heating is available, this must also be switched to a voltage-free state. Care must be taken to ensure that each individual heating circuit is voltage-free.
- Wear personal protective equipment!

## Insulated Conductor Rail System

### SinglePowerLine Program 0813

---



**DANGER!**

#### **Risk of injury due to crushing of skin and limbs!**

There is a risk of crushing of skin and limbs due to:

- Current collector (spring force) during preassembly, installation, disassembly and maintenance.
- Falling conductor rail system components, if they have not been properly installed or if operated under inappropriate operating conditions (e.g., environment that contains solvents).



**DANGER!**

#### **Danger of injury due to dust and abrasion!**

Breathing difficulties and eye irritation can occur due to thrown up dust and abrasion of the carbon brushes/sliding contacts, copper conductor bars and plastic. There is a health hazard due to airborne respirable dust. One result may be cancer. Sensitization may occur if handling the conductor rail frequently and/or carelessly handling dust accumulation. **Cancer, mucosa irritation and respiratory diseases** can be a consequence of frequent and prolonged stays in a heavily used facility without protective equipment.

- Clean regularly! If necessary, clean the system according to the instructions before starting work. See Section 12.1.
- Wear personal protective equipment.
  - Protective eyewear
  - Protective dust mask Class FFP3 (observe local regulations)
  - Protective gloves
  - Disposable coveralls
- Prevent contamination of the environment (e.g., people, goods, production facilities etc.) while cleaning by taking appropriate measures (use covers, barriers, filter systems).
- Do not **blow out dust** with compressed air, but rather vacuum it away. The vacuum must be equipped with a Class HEPA H fine filter.
- Do not eat and/or drink in the work area! Do not store or consume open food in the immediate vicinity!
- See Section 2.8.3 for further information.



**DANGER!**

#### **Risk of injury due to cutting and amputation!**

Cuts and amputations can occur on:

- Sharp edges of the general components.
- Sharp edges of the conductor rails.
- Cut edges when trimming the conductor rails.
- Packaging materials (cartons, bands, etc.).

- Wear personal protective equipment!

## Insulated Conductor Rail System

### SinglePowerLine Program 0813

---



**DANGER!**

#### **Risk of injury due to ensnarement, punctures and stabs and/or impacts!**

An ensnarement, puncture or stab and/or impact with moving conductor rails (slip ring) or current collectors connected to the machine and other components must be prevented.

Risk of injury from impacts and punctures/stabs from the conductor rail sliding out when holding the rails at an angle, from carelessness with long goods or from falling conductor rails in areas with pedestrian traffic.

- Cordon off the work area.
- Use caution when working in the vicinity of the danger zone, in particular if protective devices (covers, enclosures, control devices, etc.) have been removed or deactivated.
- Wear personal protective equipment!



**WARNING!**

#### **Fire hazard due to overload or sparking!**

Fire hazards due to overloaded cables, electrical arcs, short circuits or sparking.

- Before recommissioning, ensure that all work has been completed and all components have been properly installed!
- Conduct prescribed electrical testing!
- Permissible current values must be observed!
- Electrical fuses must be installed in accordance with regulations!
- Warn against misuse!
- Do not store easily ignited materials near to conductor rails!
- Carry out dimensioning according to permissible system load capacity and provide for appropriate electrical protective devices!



**CAUTION!**

#### **Before switching the system on!**

- Every time before the product or system is started, measure the insulation resistance according to locally applicable technical standards, directives and legal regulations.
- Conduct locally required electrical tests.



**WARNING!**

#### **Risk of burns due to hot surfaces**

Components can become hot during operation.

- Operation is only permitted in areas inaccessible to the public and out of manual reach!  
The danger zone must be enclosed by the customer or protection ensured by distance.
- Protective devices are to be provided by the customer!
- Cordon off the work area!
- Use caution when working in the vicinity of the danger zone, particularly if protective devices (covers, enclosures, control devices) have been removed or are not activated!
- Wear personal protective equipment!
- Allow hot surfaces to cool before removing the fault.

## Insulated Conductor Rail System

### SinglePowerLine Program 0813



**DANGER!**

**Danger due to improperly completed maintenance work**

- Before recommissioning, ensure that all work has been completed and all components have been properly installed.
- Conduct electrical testing as prescribed.
- Electrical fuses must be installed according to regulations.

## 10.2 Fault correction table

Fault	Cause	Corrective Measures
Sliding contacts are unevenly worn.	Range of movement of the current collector head is restricted	Use original current collector heads from Conductix-Wampfler (ensure freedom of movement). Mount current collector according to Section 6.4.4 . Check the installation position at various points in the system.
	Contact pressure is too high or low.	Mount current collector according to Section 6.4.4; Use original connecting cables from Conductix-Wampfler (use superfine-stranded Class 6 connecting cables (in accordance with IEC 60228)).
Sliding contact insulation is abraded on the side down to the sliding contacts.	For horizontal installation: The height of the current collectors is not set correctly.	Replace current collector heads; correctly adjust the height of the current collector.
Sliding contacts wear out too fast.	Sharp edges on the power terminal, conductor rails, connections between the conductor rails.	Smooth out sharp edges with a file, compressed-air grinder or sanding paper.
	Conductor rails soiled or scorched in places.	Check current values; clean rails as specified in Maintenance Instruction WV0800-0002; if necessary, replace conductor rails.
	Contact pressure too high.	Mount current collector according to Section 6.4.4. Check the installation position at various points in the system.
The power supply is not continuous, contact is disrupted.	Line feed connector and feed terminal not properly connected.	Tighten all screws to the specified torque, see 6.4.2; If necessary, recrimp and reinstall the crimping cable lug.
	Current collector not properly connected.	Install current collector as specified in Section 6.4.4; correct



Insulated Conductor Rail System

SinglePowerLine Program 0813

Fault	Cause	Corrective Measures
		connecting cable, replace if necessary
	Contact pressure too low.	Only use original Conductix-Wampller current collectors, check cable position (ensure that cables can move freely). Install current collector as specified in Section 6.4.4; correct connecting cable, replace if necessary. Check the installation position at various points in the system.
	Collision with system components.	Consolidate project-specific documents, fasten affected components without collision, replace damaged components.
	Abrasive dust has collected at one of the more frequently used transfer points (where the direction of travel is reversed).	Adjust the consumer's movement profile. Move over the end position to slide the collected abrasive dust out of the conductor bar. Clean the conductor bar.
Insulating profile is not engaged in the hanger clamp.	Conductor rail has not been properly mounted.	Snap in the insulation profile, check components, replace if necessary. Install the conductor rail as described in Section 6.4.3.2 .
	Use of damaged components.	Replace damaged components.

## Insulated Conductor Rail System

SinglePowerLine Program 0813

---

### 11 Disassembly and Disposal

---

#### 11.1 Safety

##### Personnel:

- May only be conducted by trained technicians. Recommendation: Min. 2 people

##### Recommended protective equipment:



##### Requirements:



**DANGER!**

##### Prior to starting the disassembly:

- Completely disconnect the conductor rail system from the power supply and secure it against switching on again.



**DANGER!**

##### Risk of death due to electrical shock!

Contact with components carrying electrical power can lead to death or severe injury due to electrical shock. Danger of injury due to shock reactions, falling or being thrown across the room due to electrical shock.

- The main power supply (from the building) and heater power supply must be disconnected in the dismantling area and secured against switching on again.
- Disconnect all line feeds from the voltage supply.
- Observe the 5 Safety Rules(see Section 2.7)!
- When decommissioning, check whether a voltage is still present in the components and take measures where necessary.
- If a conductor rail heating is available, this must also be switched to a voltage-free state. Care must be taken to ensure that each individual heating circuit is voltage-free.
- Ensure secure footing!

## Insulated Conductor Rail System

### SinglePowerLine Program 0813

---



**WARNING!**

#### **Danger of injury due to improper disassembly!**

Stored residual energy, sharp components, and points and edges on and in the product or the required tools can cause injuries.

- Ensure that there is sufficient space before starting work.
- Handle open, sharp-edged components carefully.
- Ensure the workplace is tidy and clean! Loosely stacked or scattered components and tools are a source of hazards.
- Disassemble components properly. Be aware of the dead weights of the components. If necessary, use lifting gear.
- Secure components so they cannot fall or topple.



**DANGER!**

#### **Risk of injury due to cutting and amputation!**

Cuts and amputations can occur on:

- Sharp edges of the conductor rails.
  - Cut edges when trimming rails.
- Wear personal protective equipment!
  - Cordon off the work area!
  - Use caution when working in the vicinity of, and particularly below, the conductor rail.



**DANGER!**

#### **Risk of injury due to crushing of skin and limbs!**

There is a risk of crushing of skin and limbs due to:

- Current collector (spring force) during preassembly, installation, disassembly and maintenance.
- Falling parts of the conductor rail system in the case of improper disassembly.



**DANGER!**

#### **Risk of injury due to impacts and punctures/stabs from conductor rails sliding out!**

Risk of injury due to impacts and punctures/stabs from conductor rails sliding out when holding the rails at an angle or carelessness with long goods.

- Wear personal protective equipment!
- Cordon off the work area!
- Use caution when working in the vicinity, particularly below the conductor rail!

## Insulated Conductor Rail System

### SinglePowerLine Program 0813

---



#### **DANGER!**

#### **Danger of injury due to dust and abrasion!**

Breathing difficulties and eye irritation can occur due to dust thrown up and abrasion of the carbon brushes/sliding contacts, copper conductor bars and plastic. There is a health hazard due to airborne respirable dust. One result may be cancer.

- Clean regularly! If necessary, clean the system according to the instructions before starting work. See Section 12.1.
- Wear personal protective equipment.
  - Protective eyewear
  - Protective dust mask Class FFP3 (observe local regulations)
  - Protective gloves
  - Disposable coveralls
- Prevent contamination of the environment (e.g., people, goods, production facilities etc.) while cleaning by taking appropriate measures (use covers, barriers, filter systems).
- Do not **blow out dust** with compressed air, but rather vacuum it away. The vacuum must be equipped with a Class HEPA H fine filter.
- See Section 2.8.3 for further information.



#### **WARNING!**

#### **Risk of injury when removing the connector!**

Compared to the insulation profile and the conductor bar, the connector is very large component and e.g., a saw blade could easily become trapped in it. The saw could also spring out and injure the installer.

- When separating the 4 m rail segments, keep at a distance of at least 100 mm from the end of the insulation profile.



#### **CAUTION!**

#### **Reusing disposable components can create hazards!**

Reusing a connector, for example, can create the following hazards:

- The connection is not perfect and reliable.
  - High-resistance connection, heating, fire hazard, reduced performance.
- Dispose of disassembled connectors and replace with new ones. Do not reuse!

## Insulated Conductor Rail System

### SinglePowerLine Program 0813

---

#### 11.2 Disassembly

After the end of its service life, the product must be disassembled and disposed of in an environmentally friendly manner.

- Remove operating and auxiliary materials, as well as residual processing materials, and dispose of them in an environmentally appropriate manner.
- Clean the subassemblies and components properly and disassemble and dispose of them in compliance with locally applicable occupational safety and environmental protection regulations.

#### Required tools

- Disassembly tool (Order No.:08-V015-0493) (see work steps on P. 55)
- Hexagon screwdriver AF 5
- Open-end wrench AF 8, AF 10, AF 17
- Screwdriver set
- Cutting tool (e.g., jigsaw/angle grinder)
- Tools for securing

#### 11.3 Disposal

In the absence of a return or disposal agreement, disassembled components must be recycled as follows:

- Metal components must be recycled.
- Plastic components must be recycled.
- The other components are to be disposed of according to their material composition.



**CAUTION!**

#### **Environmental damage due to improper disposal!**

Electrical waste, electronic components, lubricants, and other auxiliary materials are subject to hazardous waste disposal regulations and may only be disposed of by authorized specialists.

Local authorities or specialist disposal companies can provide information regarding environmentally appropriate disposal.

## Insulated Conductor Rail System

SinglePowerLine Program 0813

---

### 12 Further Documents

---

#### 12.1 Applicable documents

ID No.	Document Number	Document Name
01	WV0800-0001	Cleaning of Conductor Rails
02	WV0800-0002	Maintenance Schedule Conductor Rails
03	MV0813-0010	Grounding and short-circuit device
04	MV0813-0014	Disassembly Tool 0813
05	MV0813-0015	Heating Wire 0813
06	MV0813-0016	Quick Guide Conductor Rail System 0813
07	MV0800-0018	Insulation measurement of heating wires
08	MV0800-0019	Insulation measurement of conductor rails

Insulated Conductor Rail System

SinglePowerLine Program 0813

---

12.2 Air gap diagram

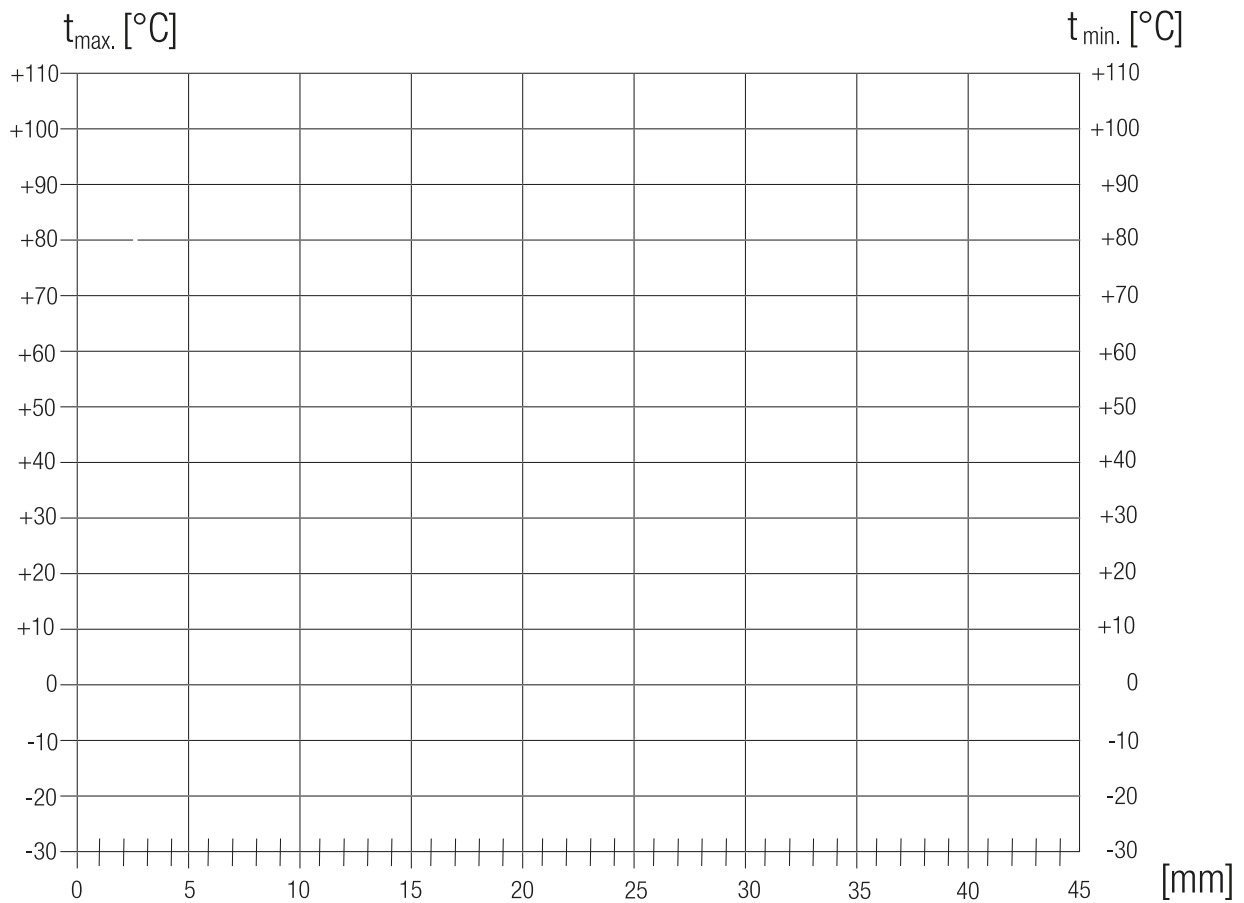

## Insulated Conductor Rail System

### SinglePowerLine Program 0813

---

## 13 Index

---

Accessories .....	33	Packaging .....	39
Accidents .....	17	Personnel requirements .....	8
Commissioning .....	85	Product Description .....	22
Copyright .....	6	Protection against contact .....	44
Description of the components .....	26	Protective measures .....	12
Disassembly .....	114	Replacement parts .....	6
Disassembly and Disposal .....	111	Required tools .....	46
Disposal .....	114	Safety .....	40, 85, 96, 111
Documents .....	115	Safety Instructions .....	7
Explanation of symbols .....	7	Safety Rules .....	12
Fault correction table .....	109	Special hazards .....	13
Functional Principles .....	22	Storage .....	39
Further Documents .....	84	Technical Data .....	18
Initial commissioning .....	91	Technical support .....	6
Installation .....	40	Tools and materials .....	100
Intended use .....	10	Training .....	9
Limitation of liability .....	5	Transport .....	38
Maintenance and Service .....	96	Trim conductor rail .....	46
Malfunctions .....	17	Troubleshooting .....	106
Material defects .....	6	Unauthorized persons .....	9
Operation .....	92	Unintended use .....	11
Operator .....	12	Unsuitable ambient conditions .....	21

### Conductix-Wampfler GmbH

Rheinstraße 27 + 33  
79576 Weil am Rhein - Markt  
Germany

Phone: +49 (0) 7621 662-0  
Fax: +49 (0) 7621 662-144  
[info.de@conductix.com](mailto:info.de@conductix.com)  
[www.conductix.com](http://www.conductix.com)



Importer for the United Kingdom:

### Conductix-Wampfler Ltd.

1, Michigan Avenue  
Salford  
M50 2GY  
United Kingdom

Phone: +44 161 8480161  
Fax: +44 161 8737017  
[info.uk@conductix.com](mailto:info.uk@conductix.com)  
[www.conductix.com](http://www.conductix.com)