



Conductor Rail System

ChargeLine 0865

Contents

1	Safety	4
1.1	Warnings and symbols	4
1.2	Intended use	5
1.3	Improper use	5
1.4	Operator responsibility	6
1.5	Personnel requirements	7
1.6	Personal protective equipment	7
1.7	Product-specific safety instructions	8
1.8	Five Safety Rules for working on electrical systems	10
2	General Information	11
2.1	Copyright	11
2.2	Brands	11
2.3	Disclaimer	11
2.4	Limitation of liability	11
2.5	Warranty	12
2.6	Customer service	12
2.7	About this document	13
3	Technical Data	14
3.1	Mechanical	14
3.2	Electrical	15
3.3	Ambient conditions	16
4	Description and Functional Principle	17
5	Scope of Delivery	19
6	Transport, Packaging and Storage	22
6.1	Transport inspection	22
6.2	Storage of packaged parts	22
7	Installation	23
7.1	Tools and materials	23
7.2	Preparations on the support profile	23



Conductor Rail System

ChargeLine 0865

7.3	Tolerances	23
7.4	Difference between 2-pole and 3-pole pickup guide	24
7.5	Work steps	25
8	Commissioning	42
8.1	Check list	42
8.2	Measuring the insulation resistance	45
9	Operation	46
10	Faults	47
10.1	Fault correction	47
10.2	Handling unknown faults	50
11	Maintenance and Service	51
11.1	Maintenance plan	51
11.2	Replacing the conductor rail within a section	52
11.3	Cleaning the conductor rail	52
12	Disassembly and Disposal	53
12.1	Disassembly	53
12.2	Disposal	53
13	Additional Documents	55
14	Approvals and Standards	56
15	Index	57

1 Safety

1.1 Warnings and symbols

This document contains safety-relevant information in various places. The safety section contains general safety instructions that are relevant for several or all phases of the product life cycle. Further safety instructions relating to a specific phase of the product life cycle can be found at the beginning of the corresponding section.

Warnings are also used. These are identified by symbols and signal words. The symbol indicates the type of danger, the signal word indicates the degree of danger. Warnings are handling-related additions that are placed directly next to the respective work step.

Always observe all safety and hazard information and work carefully to avoid accidents, bodily injury or material damage.

The product safety labels, i.e. the symbols affixed to the product, must also be observed. Product safety labels must not be removed from the product. If they have been removed from the product, they must be replaced.



DANGER!

... indicates an immediately hazardous situation, which if not avoided, may result in death or serious injury.



DANGER!

... indicates an immediately hazardous situation due to electrical current, which if not avoided, may result in death or serious injury.



WARNING!

... indicates a potentially hazardous situation, which if not avoided, may result in death or serious injury.



WARNING!

... indicates a potentially hazardous situation due to electrical current, which if not avoided, may result in death or serious injury.



CAUTION!

... indicates a potentially hazardous situation, which if not avoided, may result in moderate or minor injury and material damage.

Conductor Rail System

ChargeLine 0865



Tips and recommendations:

... refers to useful tips and recommendations as well as information for efficient and trouble-free operation.



... indicates actions that will help avoid material damage.

ATTENTION!

1.2 Intended use

The Conductor Rail System ChargeLine 0835 is an electric power supply system for mobile consumers operated in indoor spaces in warehouse areas not accessible to the public. One of its typical applications is, e.g. to supply power to shuttles inside a warehouse with horizontal storage racks.

Intended use also includes compliance with all the information in this document.

See the "Technical Data" section.

1.3 Improper use

Any use that deviates from or goes beyond the intended use described here involves considerable risks for people and materials.

Improper use particularly includes, but is not limited to:

- Operation outside the stated technical specifications
- Operation outside the specified operating and ambient conditions
- Operation without initiating measures resulting from the operator's risk assessment
- Operation under ambient conditions that permanently damage the material properties and/or reduce the insulating properties
- Operation in areas with flammable or explosive gases and/or dusts
- Exceeding the max. system length
- Installation in an area accessible to the public without protective devices
- Overloading of current collectors and conductor rails due to excessive current and voltage
- Operation in areas that require a higher degree of protection than specified
- Use of the conductor rail system as a climbing aid
- Use of unsuitable cleaning agents
- Use of accessories not supplied and not approved or authorized by the manufacturer
- Use of spare parts that have not been approved by the manufacturer
- Use of tools that are not intended for professional use
- Operation of the system by untrained and insufficiently qualified personnel
- Execution of any work on the system by insufficiently qualified personnel
- Overriding of safety devices
- Use of different conductor materials without additional measures

Conductor Rail System

ChargeLine 0865

1.4 Operator responsibility

The product is used in the industrial sector. The operator is therefore subject to the legal obligations relating to workplace safety. In addition to the warning and safety instructions in this document, all safety, accident protection and environmental regulations valid in the place of operation of the product must also be observed.

This particularly applies to the following:

- The operator must ensure protection against electric shock (protection against indirect contact).
- The operator must be informed of the applicable workplace safety regulations and identify any additional dangers that may arise from the specific working conditions at the system operating site. These must be implemented in the form of operating instructions for operating the system.
- The operator must examine the system during the entire operating period and determine whether the operating instructions issued by the operator comply with the current state of the regulations. The operating instructions must be updated as necessary.
- The operator must clearly regulate and define the responsibilities for installation, operation, maintenance and cleaning.
- The operator must ensure that all personnel who are involved with the system have read and understood these instructions. In addition, the operator must also train the personnel at regular intervals and inform them of dangers.
- The operator must provide the necessary personal protective equipment to the required personnel.
- The operator must store the keys for the switching cabinets securely, i.e. only expressly authorized persons may have access to the keys.
- The operator must ensure that the service intervals specified in this document are observed.
- The operator must ensure that the check points for functionality are carried out before initial commissioning in accordance with this document.
- The controls and safety devices provided by the operator for operating the system must be checked for functional safety and completeness.

Conductor Rail System

ChargeLine 0865

1.5 Personnel requirements

All activities may only be carried out by qualified and trained personnel. Inadequate training in the use of the product may result in serious personal injury or material damage. The qualifications listed are mentioned in this document for various areas of application.

Operator

- may take on tasks within the scope of normal operations.
- have been instructed by the operator in this regard and familiarized with the potential dangers.

Qualified electricians

- are persons who are specially trained for the working environment surrounding electrical systems.
- are persons who are capable of independently performing assigned tasks on electrical systems based on their professional training, knowledge and experience, who also are able to independently recognize and avoid potential hazards.
- possess an understanding of the applicable standards and regulations.
- The operator must document that the relevant certificates or other proofs of qualification are available or have been verified.

Electrically trained persons

- have been trained by a qualified electrician.
- know the potential dangers of improper conduct.
- know the necessary protective measures and protective equipment.
- are supervised by a qualified electrician.

Specialist personnel

- consists of persons who are capable of independently performing assigned tasks based on their professional training, knowledge and experience, who also are able to independently recognize and avoid potential hazards.
- possess an understanding of the applicable standards and regulations.

Minimum 2 persons

- At least 2 people are required to carry out specific activities

1.6 Personal protective equipment



Protective footwear

For protection against heavy falling parts and slipping on slippery floors.



Protective gloves (mechanical)

For the protection of hands against friction, abrasions, punctures or deeper wounds.



Protective eyewear

For eye protection against mechanical and chemical hazards.



FFPE protective mask

To protect against serious and permanent respiratory diseases. An FFP3 mask is recommended when working with very high dust levels.

1.7 Product-specific safety instructions

The dangers presented here describe residual risks that may arise from the product even when used as intended.

1.7.1 Electrical hazards



DANGER!

Risk of death due to electrical shock!

Contact with electrical components can lead to death or severe injury.

- Do not touch the energized current collector.
- Do not use damaged electrical components and/or cables.
- Observe the Five Safety Rules.



WARNING!

Fire hazard due to overload or sparking!

Fire hazards occur due to overloading the system or individual components (e.g. cables, current collectors, etc.), from electric arcs, short circuits, or sparking.

- Comply with permissible current ratings.
- Easily combustible materials may not be stored near the product.
- Observe installation tolerances.
- Easily combustible materials may not be stored in close proximity to conductor rails.
- Check, service and the clean conductor rails regularly and as specified.

Conductor Rail System

ChargeLine 0865

1.7.2 Mechanical hazards



WARNING!

Risk of injury due to sharp edges!

When working on the conductor rail, skin and limbs may be cut or severed.

- Wear personal protective equipment for all work.



WARNING!

Risk of death due to suspended loads!

When lifting loads, there is a risk of death due to falling or swinging parts.

- Never walk under suspended loads.
- Only move loads under supervision.
- Observe the specifications for the intended attachment points.
- Never attach parts to projecting machine parts or to eyelets on installed components.
- Check that lashing components are securely seated.
- Only use authorized lifting gear and separate lifting accessories with sufficient load capacity.
- Do not use torn or worn ropes or straps, replace with new ones if necessary.
- Do not attach ropes or straps to sharp corners and edges.
- Do not knot or twist ropes or straps.
- Set down all suspended loads before leaving the work area.



DANGER!

Risk of injury due to long objects!

When being transported on the installation site, there is a risk that the conductor bars may slide out of the insulation profiles if they are not held vertically during transport. Considering the sharp facings, this can cause serious injury and even death if they fall from a great height.

- The conductor rails are to be transported near to the installation site while still inside their packaging.
- The conductor rails must be transported to the installation site by two people and care must be taken that the conductor bars do not slide out of the insulation profiles.



WARNING!

Risk of injury due to impacts!

Moving components of the conductor rail system can cause injuries to limbs.

- Point out this risk to specialist personnel during instruction.
- Avoid areas containing solvents, as these can cause plastic parts to break. Broken components may cause these or other components to fall.
- Take precautions against falling parts.



DANGER!

Risk of injury due to ensnarement!

There is a risk of being ensnared by moving parts when the system is in operation.

- Do not enter the danger zones of the system during operation.
- Point out this risk to specialist personnel during instruction.

Conductor Rail System

ChargeLine 0865



WARNING!

Risk of injury due to crushing of skin and limbs!

The spring force of the current collector can lead to the crushing of skin and limbs.

- Wear personal protective equipment for all work on the conductor rail system.

1.7.3 Danger due to substances



DANGER!

Health hazards due to dust!

The abrasion from the sliding contacts is harmful to health. Frequent handling of the conductor rail system and/or careless handling of dust accumulations can lead to sensitization, mucous membrane irritation, respiratory diseases and cancer.

- Wear an FFP3 protective mask when working with very high levels of dust.

1.8 Five Safety Rules for working on electrical systems

Follow the Five Safety Rules (see DIN VDE 0105-100):

1. Disconnect the system from power at the main switch.
2. Secure the main switch against being turned back on.
3. Verify disconnection from power by measuring.
4. Ground and short-circuit parts of the system on which work will be conducted.
5. Cover or block off adjacent energized parts.

2 General Information

This document is part of the product and enables safe and efficient handling of the product. It must be kept accessible to personnel at all times.

Compliance with all warnings, safety instructions and instructions for use is a basic prerequisite for safely working with the product. Furthermore, the local accident prevention regulations and general safety regulations for the use of the system or machine apply.

This document does not provide instructions for operating the system or machine in which the product is integrated.

Illustrations are provided for basic understanding and may deviate from the actual implementation.

2.1 Copyright

The contents of this document are protected by copyright and are subject to industrial property rights. Any misuse is punishable by law.

Reproduction of this document, including excerpts, is only permitted within the limits of the statutory provisions of copyright law.

Any modification or abridgement, except for internal purposes, without the express consent of Conductix-Wampfler is prohibited.

2.2 Brands

The names, trade names, goods identification, etc. in this document may be trademarks, even if not specifically marked accordingly, and as such are subject to legal provisions.

2.3 Disclaimer

The contents of this document have been reviewed for concurrence with the product described. Nevertheless, because deviations cannot be entirely ruled out, we assume no liability for the complete concurrence. Necessary corrections are included in the subsequent versions.

2.4 Limitation of liability

The contents of this document have been compiled taking into account the applicable standards and regulations, the state of the art and Conductix-Wampfler's many years of knowledge and experience.

Conductix-Wampfler accepts no liability for damage or operational faults resulting from:

- Non-compliance with the technical documentation
- Improper use
- Use of untrained specialist personnel
- Unauthorized modifications and technical changes
- Use of unauthorized spare parts or accessories
- Use of the product, despite a negative transport inspection
- Disadvantages that arise if the product does not function properly

The actual scope of delivery may differ from the explanations and descriptions provided here if the model in question is a special one, if additional equipment has been ordered or is due to recent technical changes.

Conductor Rail System

ChargeLine 0865

The obligations agreed upon in the delivery agreement and our General Terms and Conditions apply, as do the delivery conditions of the manufacturer and the legal regulations applicable at the time the contract was concluded.

Conductix-Wampfler reserves the right to make technical changes within the context of improvement of function and further development.

2.5 Warranty

The warranty period and the scope of the warranty are determined by your contractual conditions and by Conductix-Wampfler's General Terms of Delivery.

The warranty does not apply in the following circumstances:

- Changes to the product without the consent of Conductix-Wampfler
- Improper handling, transportation or maintenance of the product
- Use of parts that are not original Conductix-Wampfler parts
- Non-compliance with this document
- If tolerances are not observed

2.6 Customer service

All Conductix-Wampfler employees are always interested in new information and on-site experience that can contribute to improving the products.

Customer service is available for all technical questions.

Conductix-Wampfler GmbH
Rheinstrasse 27 + 33
D – 79576 Weil am Rhein – Märkt
Phone: +49 (0) 7621 662-0
Fax: +49 (0) 7621 662-144
Email: info.de@conductix.com
www.conductix.de
Country of origin: Germany

Worldwide sales and service location addresses:

www.conductix.contact

2.7 About this document

Explanation of symbols:



Hexagon wrench:

Instruction-related information for when screws must be manually loosened or tightened is available in graphic form. If a torque is specified, a torque wrench should be used.



Instruction-related information for when dimensions must be drawn in, measured and observed is available in graphic form.



Instruction-related information for drilling components is available in graphic form.



Correct use or result:

Instruction-related information that is always contrasted with a graphic showing incorrect use or an installation error is available in graphic form.



Incorrect use or an installation error:

Instruction-related information that is always contrasted with a graphic showing the correct use is available in graphic form.



Audible click:

Indicates that product components must be audibly connected to each other during assembly. Assembly sequences that show these work steps are available.

Dimensions within the document

Dimensions without units are provided in millimeters.

Conductor Rail System

ChargeLine 0865

3 Technical Data

3.1 Mechanical

Max. travel speed on straight sections	400 m/min
Max. travel speed at guide entry	120 m/min
Driving direction	To and from
Pole spacing	14 mm
Number of poles	2, 3, 4, 5, 6 etc.
Current collector insertion	From the side or from below
Installation orientation	Horizontal
Max. length of the installed conductor rail	Maximum length without additional expansion units 50 m and variable
Max. length of the installed conductor rail, taking expansion into account	Unlimited
Conductor rail segment	Segment length variable Standard length: 500 mm 750 mm 1000 mm
Max. length including guide	4000 mm
Shortest length of a conductor rail segment	250 mm
Hanger clamp spacing	800 mm
Spacing from pickup guide to first hanger clamp	Max. 200 mm
Current collector contact force on the conductor rail	Approx. 6 N
Conductor material of the conductor rail	Copper and steel

Conductor Rail System

ChargeLine 0865

3.2 Electrical

Rate current for complete 0865 units when using 2 power feeds	100 A
Rated current for conductor rail systems consisting of 0835 and 0865 or connected units	32 A
Rated current for 0865 Mobile Unit	34 A
Rated voltage Variant 60 V Low voltage variant	AC ≤ 25 V, DC ≤ 60 V AC ≤ 230 V, DC ≤ 400 V
Assignment	1 or 2 PH, 1 PE
Cross-sections for connection cables	2.5 mm ² and 6 mm ² double insulated 2.5 mm ² , 6 mm ² and 10 mm ² single insulated
Cross-section of the current collector cable	4 mm ² double insulated
Length of the current collector cable	Configurable
Conductor rail protection class	IP 2X
Current collector protection class (outside the conductor rail)	IP 00
Current collector protection class (within the conductor rail)	IP 2X
Current collector connection cable	Cross-section 4 mm ² Always double insulated Cable length is configurable
Current collector unit	2-pole unit PH and PE version 3-pole unit PH and PE version The current collector poles on the towing plate can be assigned as required.

Conductor Rail System ChargeLine 0865

3.3 Ambient conditions

Specification	Value	Notes
Temperature range	-20° C to +55° C	In temperatures of 0° C and below, the max. relative humidity must not exceed 30%.
Transport temperature	-20° C to +55° C	
Storage temperature	-20° C to +55° C	
Relative humidity	85 %	
Max. operating temperature difference	40 K	
Environment	Dry indoor area	
Altitude above sea level	≤ 1000 m	Above mean sea level

Conductor Rail System

ChargeLine 0865

4 Description and Functional Principle

The Conductor Rail System ChargeLine 0865 is a system that charges during movement and standstill.

The conductor rail system consists of the following components:

- Hanger clamp
- Conductor rail with one or two pickup guides
- Power feed
- Optional: Connector 0835
- Optional: Conductor Rail 0835

The Conductor Rail System 0865 is similar to the Conductor Rail System 0835. The Conductor Rail 0865 can be connected or combined with conductor rails from the 0835 product range using the Connector 0835.

In order for the Conductor Rail 0865 to slide well, the fixing web at the rear side of the pickup guide is to be broken away. As a result, there is always an anchor point at one end and a sliding bearing can be produced at another end.

Using the hanger clamps, the conductor rails are attached to a customer-specific supporting construction/substructure. All lengths in the catalog are only valid for installation with a supporting construction/substructure.

The conductor rail is supplied with electrical energy via a power feed at the beginning that a mobile end user can tap into using a current collector, e.g. a shuttle.

The power feed is installed differently depending on the number of poles in the conductor rail system: In a 2-pole system, the pickup guide is mounted using an expansion rivet, while in a 3-pole system, the pickup guide is secured with cylindrical screws.

See chapter 7.4 and 7.5.2

Conductor Rail System

ChargeLine 0865

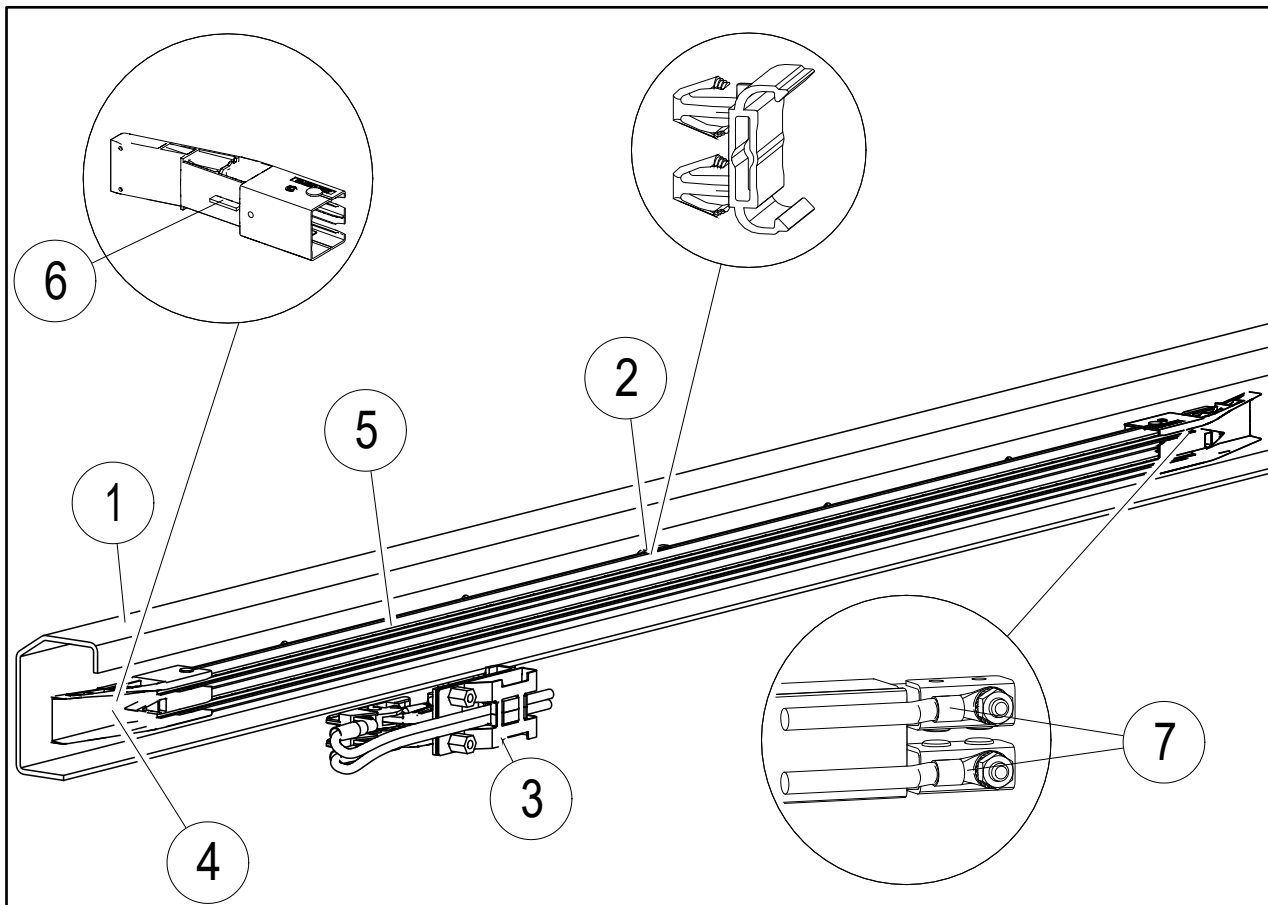

Fig. 1: System overview

Pos.	Name
1	Customer-side supporting construction/substructure
2	Hanger clamp
3	Current collector
4	Pickup guide
5	Conductor rail
6	Fixing web on pickup guide
7	Power feed/Outfeed

5 Scope of Delivery



The conductor rail system is also available in a 3-pole version.

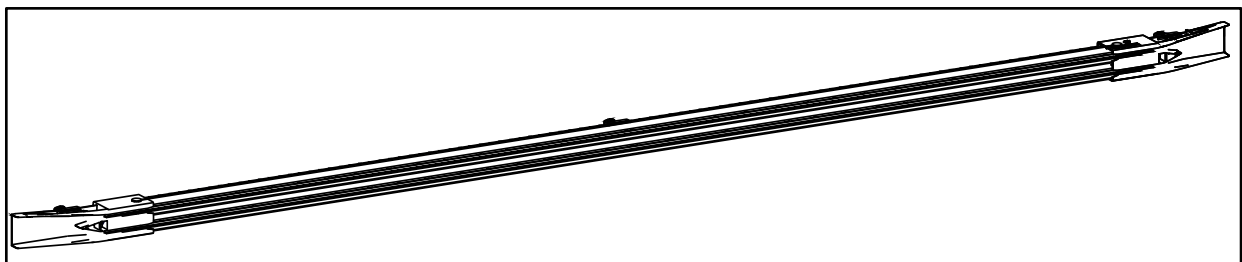

Fig. 2: Conductor rail with pickup guide (both sides)

■ Conductor Rail 0865 with two pickup guides

There are pickup guides on both sides. A power feed and outfeed point is possible on both sides. Connection cables are also possible on both sides. The length of the connection cables is configurable (max. 5 m).

Cross-section with double insulated cable: 6 mm²/2.5 mm²

Cross-section with single insulated cable: 10 mm²/6 mm²/2.5 mm²

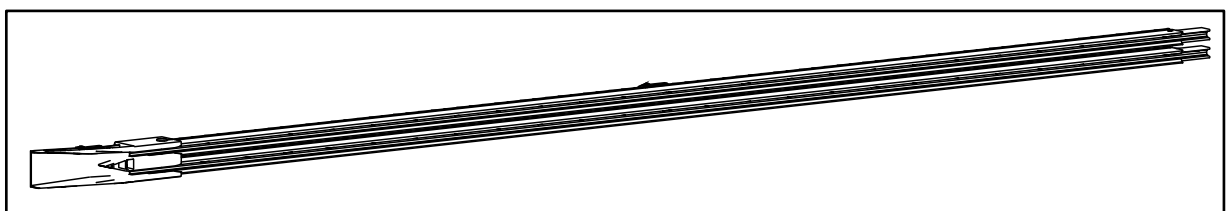

Fig. 3: Conductor rail with pickup guide (single-sided)

■ Conductor Rail 0865 with one pickup guide

There is a pickup guide on one side. A power feed or outfeed point is possible at the pickup guide. The length of the connection cables is configurable (max. 5 m).

Cross-section with double insulated cable: 6 mm²/2.5 mm²

Cross-section with single insulated cable: 10 mm²/6 mm²/2.5 mm²

Conductor Rail System

ChargeLine 0865

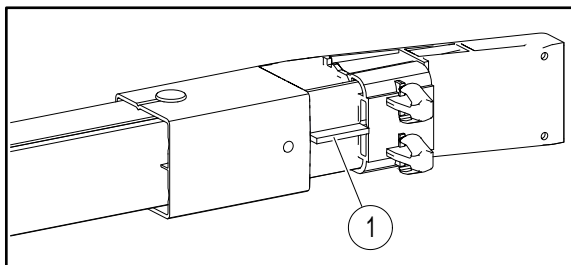

Fig. 4: Anchor point 0865/sliding bearing

■ Anchor Point 0865/sliding bearing

If the fixing web (Pos. 1) is not broken away at the rear of the pickup guide, this functions together with the hanger clamp as an anchor point.

If the fixing web (Pos. 1) is broken away, a sliding bearing is produced so that the conductor rail can expand. The conductor rail therefore has a possible expansion gap of up to 20 mm. This provides sufficient expansion space for systems with a length of up to 100 m, depending on the ambient conditions.

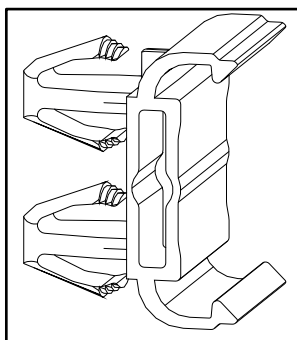

Fig. 5: Hanger Clamp 0865

■ Hanger Clamp 0865

The Hanger Clamp 0865 is attached to the customer's supporting construction with the two clips.

The conductor rail is suspended in Hanger Clamp 0865.

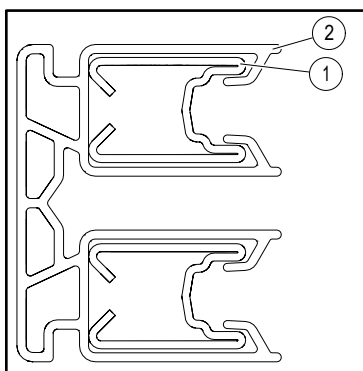

Fig. 6: Conductor Rail 0865

■ Conductor Rail 0835

The conductor rail consists of a conductor bar (Pos. 1) and an insulation profile (Pos. 2).

Conductor Rail System ChargeLine 0865

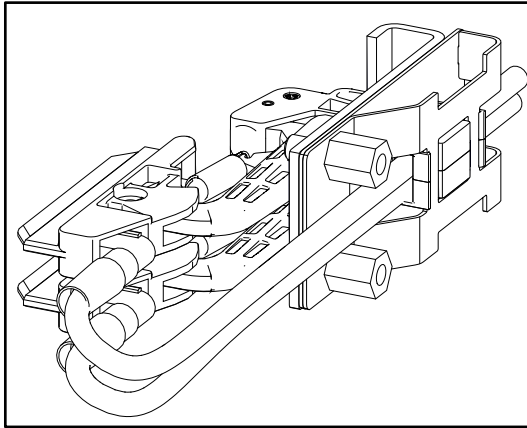

Fig. 7: Current Collector 0865

■ Current Collector 0865

The current collector supplies the track-guided mobile consumer with the required energy. It was specially designed for the new Pickup Guide 0865 and includes strain relief as well as cables. The current collector can optionally include a long cable set.

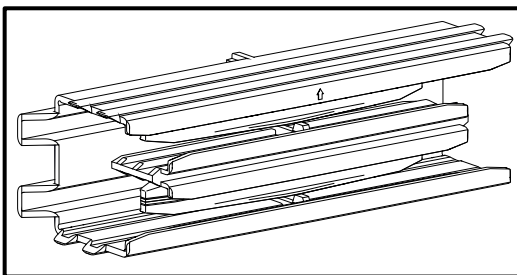

Fig. 8: Connector 0835

■ Connector 0835

The Connector 0835 is used to connect the Conductor Rail System 0865 to the Conductor Rail System 0835. Using a connector reduces the rated current to 32 A.

6 Transport, Packaging and Storage

6.1 Transport inspection

Immediately check the delivery for completeness and transport damage upon delivery, since claims for damages can only be asserted within the complaint periods.

Proceed as follows in the event of externally visible transport damage:

- Document and report any defects identified.
- Do not accept the extent of the damage or accept it only with reservations.
- Note the extent of the damage on the transport documents or on the transport company's delivery note.

If Conductix-Wampfler is the deliverer, report the incident to Conductix-Wampfler.

6.2 Storage of packaged parts

Store packaged parts under the following conditions:

- Dry and dust-free
- Do not expose to aggressive media
- Protect from direct sunlight
- Avoid mechanical vibrations
- Only set on level surfaces
- Do not destroy the packaging; remove it shortly before installation.
- Maintain the ambient conditions according to the technical specifications.
- Check the condition of the parts and their packaging regularly if the storage period exceeds three months. Relocate the packages if necessary

Conductor Rail System ChargeLine 0865

7 Installation

7.1 Tools and materials

- Crimping tool
- Cable stripper
- Plastic hammer
- Mounting Kit 0835
- Screw clamp
- File
- Drill \varnothing 9 mm
- Drill \varnothing 4.3 mm
- Drill \varnothing 3.6 mm
- Cutting tool
- Torque wrench, internal SW 3

7.2 Preparations on the support profile

See MAL0835-0002 for the preparations that must be made on the support profile.

7.3 Tolerances

The following tolerances apply to the conductor rail system:

Conductor rails/guide in the X direction	± 2 mm
Conductor rails/guide in the Y direction	± 3 mm
Gap at the connector between 2 conductor bars	2.5 mm
Current collector	± 5 mm working stroke, $\pm 2,5$ mm lateral

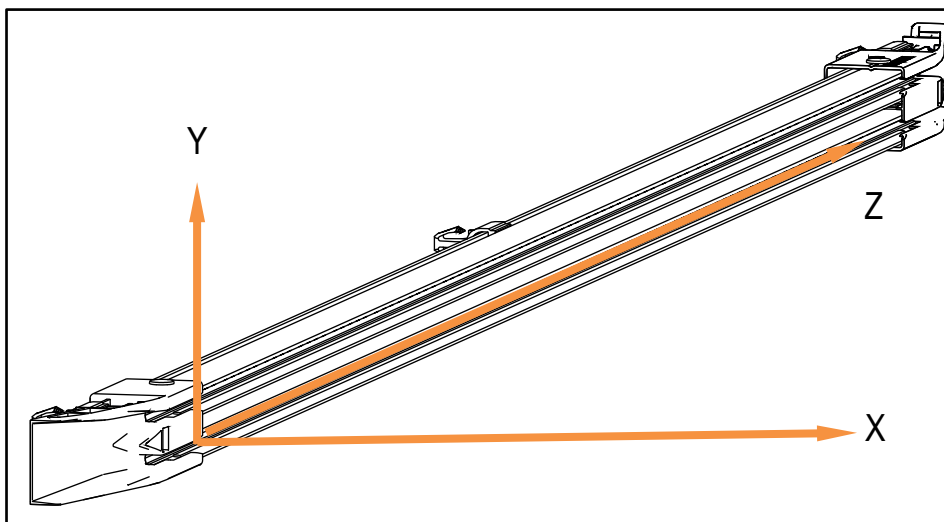

Fig. 9: Coordinate system

Conductor Rail System

ChargeLine 0865

7.4 Difference between 2-pole and 3-pole pickup guide

	No difference between 2-pole und 3-pole	There is a difference between 2-pole und 3-pole	Remark
Start of the ramp	X		
Ramp	X		
Electrical contact point	X		
Position of the hanger clamp	X		
Expansion unit	X		
Length of the pickup guide		X	The 3-pole pickup guide is longer
Fixing the pickup guide		X	3-pole: Power feed terminal with cylindrical screws 2-pole: Expanding rivet

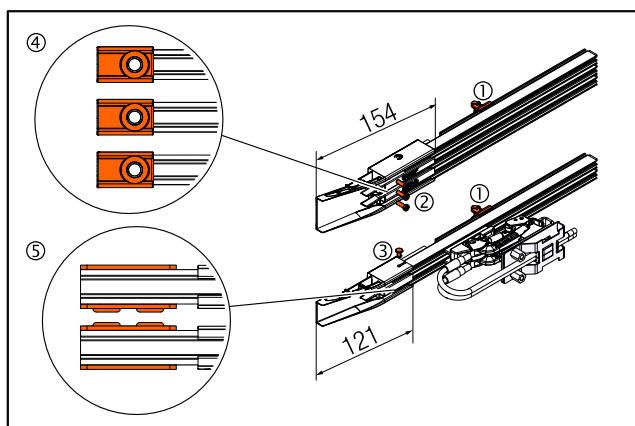

Fig. 10: Differences and similarities between pickup guide

Pos.	Name
1	Position of the hanger clamp
2	Cylindrical screws on the 3-pole pickup guide
3	Expanding rivet on the 2-pole pickup guide
4	Electrical contact point on the 3-pole pickup guide
5	Electrical contact point on the 2-pole pickup guide

Conductor Rail System

ChargeLine 0865

7.5 Work steps

7.5.1 Mounting the hanger clamps

Personnel:

- Specialist personnel

Protective equipment:

- Protective footwear
- Protective gloves (mechanical)
- Protective eyewear

Tools:

- Drill \varnothing 9 mm
- Drill \varnothing 4.3 mm

Requirement:

- The support profile is **level** and free of interfering contours (e.g. screw heads).



ATTENTION!

A clearance of at least 4 mm must be maintained between the conductor rail and any metal components (see Fig. 11) in order to prevent mechanical collisions and to ensure sufficient electrical insulation distances!

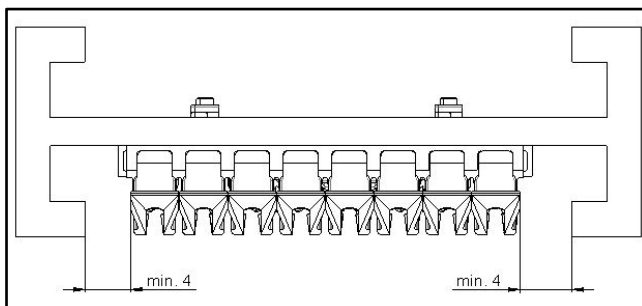

Fig. 11: Side clearance min. of 4 mm (Illustration does not correspond to the product described here)

Work steps:

→ If there are no holes in the customer's supporting construction/substructure, these must be drilled.

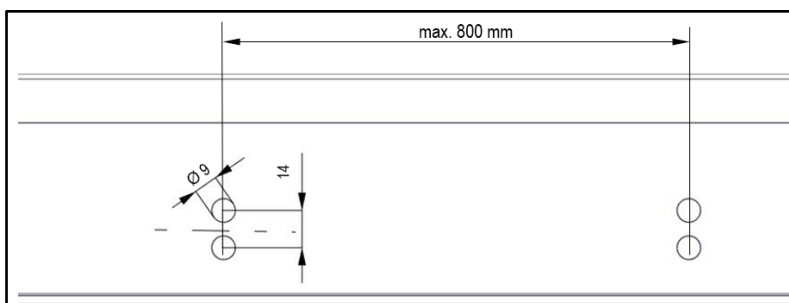

Fig. 12: Drilling pattern for 2-pole hanger clamp spacing

Conductor Rail System ChargeLine 0865

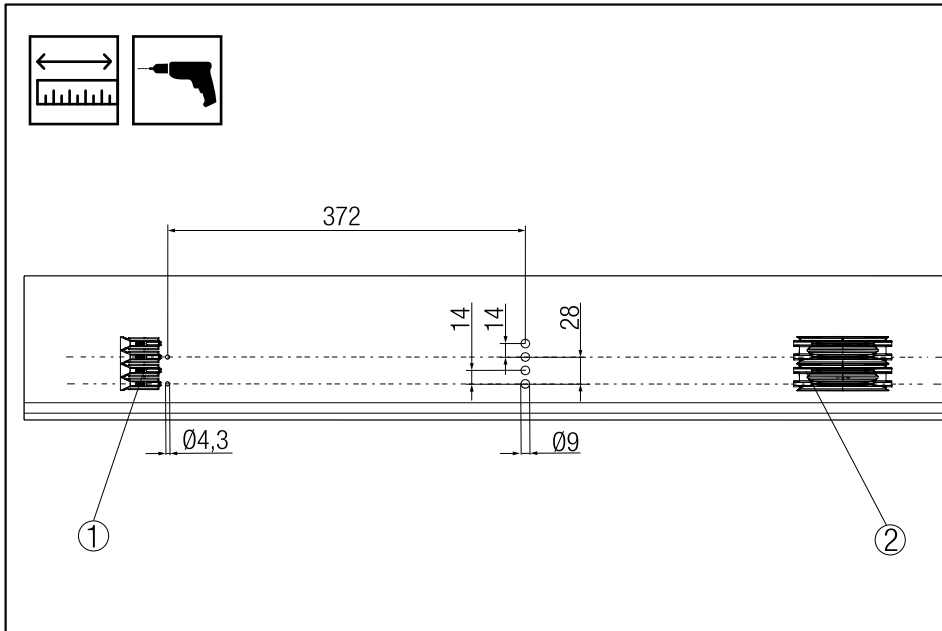

Fig. 13: Spacing in a combined system: 2-pole and 2-pole

Pos.	Name
1	Power feed for end cap base
2	Connector

Conductor Rail System ChargeLine 0865

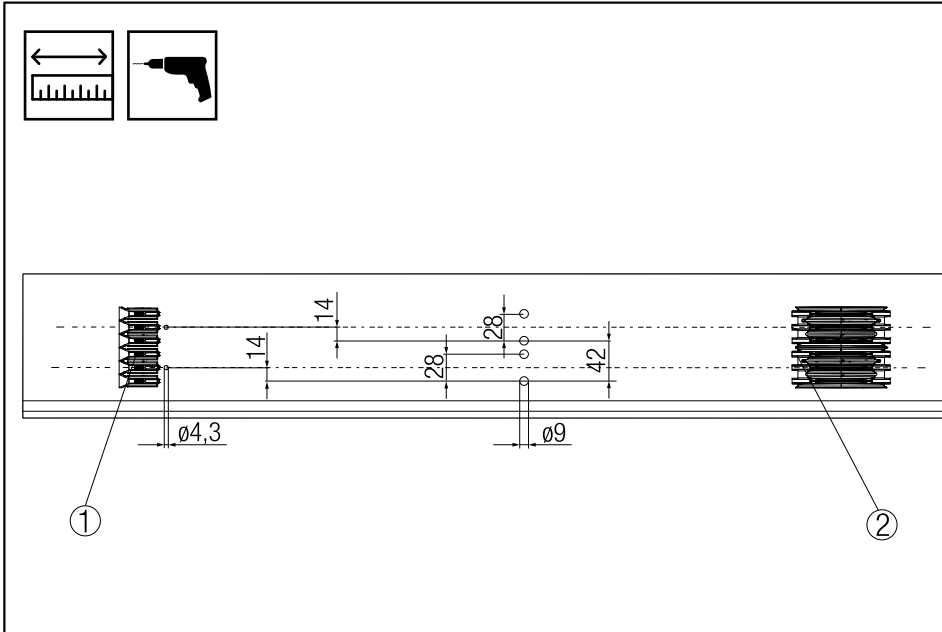

Fig. 14: Spacing in a combined system: 3-pole and 3-pole

Pos.	Name
1	Power feed for end cap base
2	Connector

Conductor Rail System ChargeLine 0865

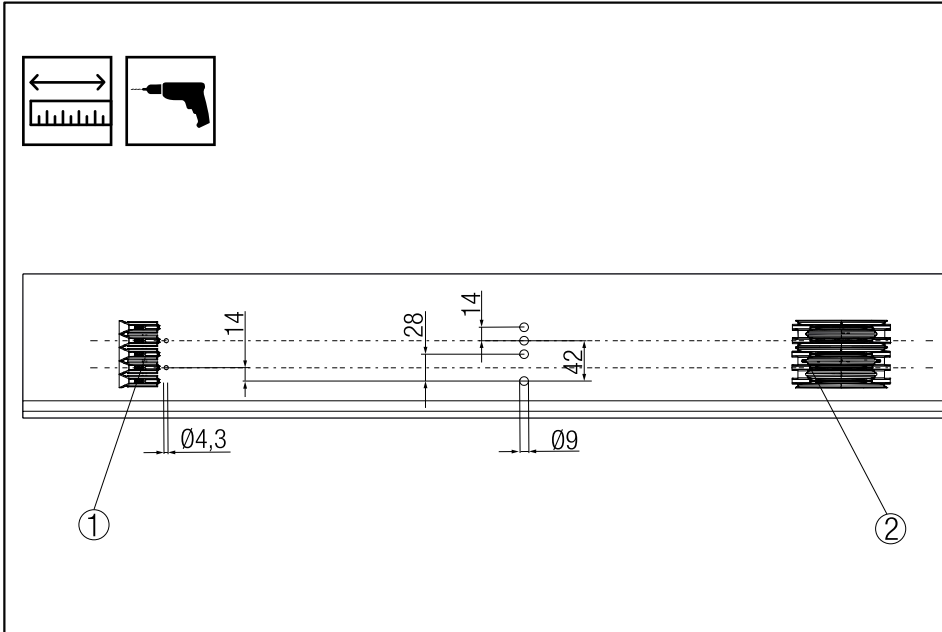

Fig. 15: Spacing in a combined system: 2-pole above and 3-pole below

Pos.	Name
1	Power feed for end cap base
2	Connector

Conductor Rail System

ChargeLine 0865

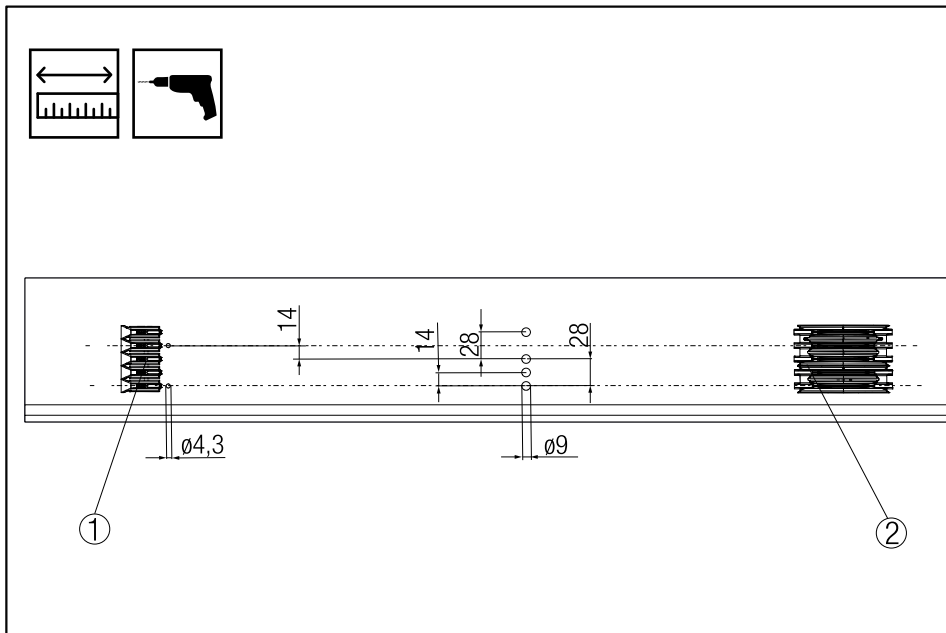

Fig. 16: Spacing in a combined system: 3-pole above and 2-pole below

Pos.	Name
1	Power feed for end cap base
2	Connector

→ Observe the hanger clamp spacing dimensions.

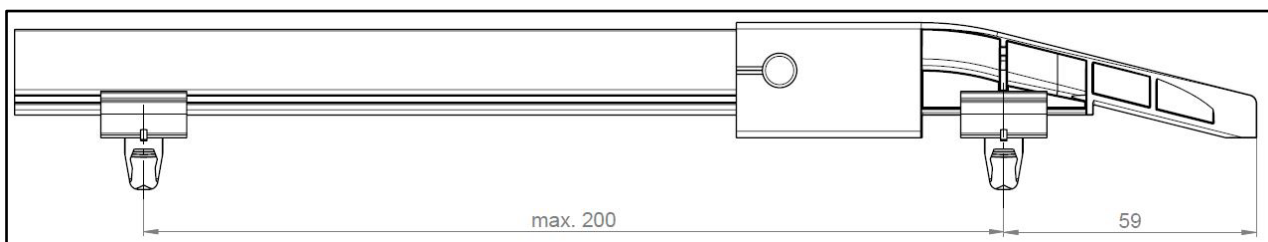

Fig. 17: Pickup guide without fixing web

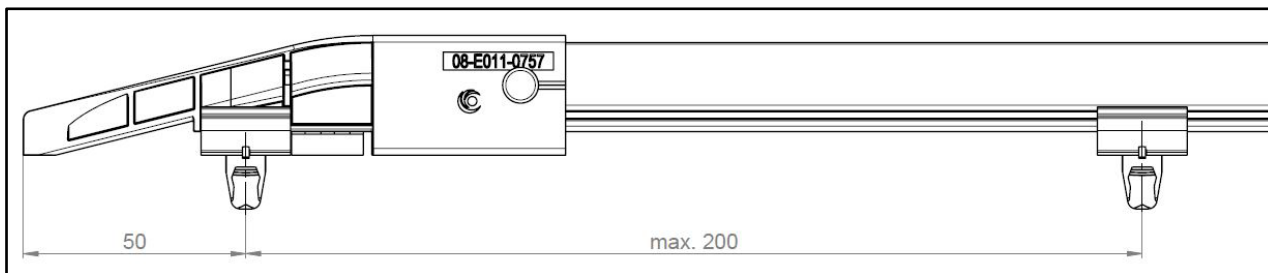

Fig. 18: Pickup guide with fixing web

Conductor Rail System ChargeLine 0865

→ Mount the hanger clamps to the customer's supporting construction/substructure.

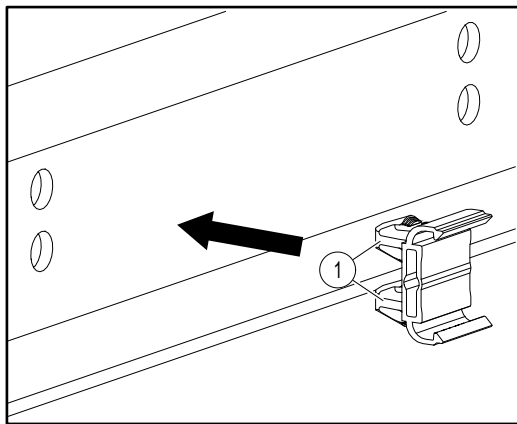

Fig. 19: Insert hanger clamp (Pos. 1) clips into hole

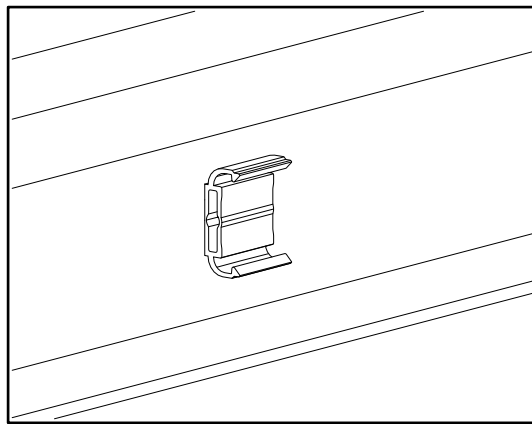

Fig. 20: Hanger clamp is mounted on customer's supporting construction/
substructure

7.5.2 Mounting the power feed

Personnel:

- Specialist personnel
- Qualified electricians

Protective equipment:

- Protective footwear
- Protective gloves (mechanical)
- Protective eyewear

Tools:

- Plastic hammer
- Crimping tool
- Cable stripper
- Torque wrench, internal SW 3

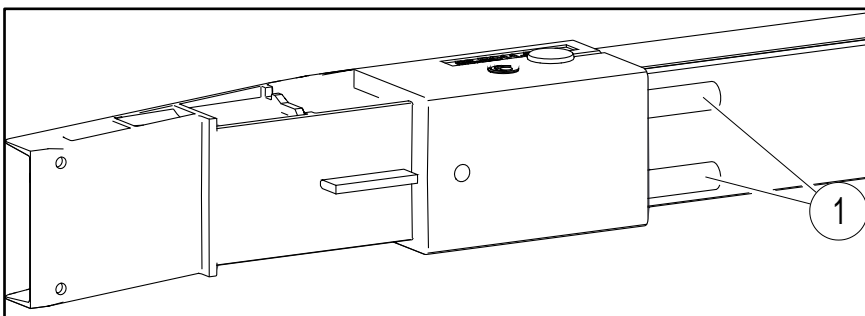

Fig. 21: Conductor Rail System 0865 connection cables

Conductor Rail System

ChargeLine 0865

If no guide is premounted on the 2-pole system, the following work steps must be carried out:

- Screw the crimping cable lug (Pos. 3) to the bolt (Pos. 2) of the power feed connector (Pos. 1) with the spring washer (Pos. 4) and hexagon nut (Pos. 5) into place.
- Strip connection cable ends (Pos. 6) and crimp them using the crimping cable lugs.
- Slide the pickup guide (Pos. 7) over the end of the conductor rail.
- Tap the expanding rivet (Pos. 8) into the hole with a plastic hammer.
- The power feed connection cables are to be connected at the end consumer by a qualified electrician. Observe local standards and guidelines.

NOTE: Ensure that the PE strip forms a continuous strip.

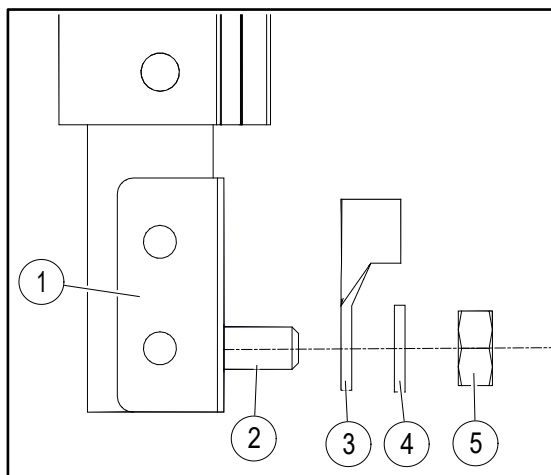

Fig. 22: Screw on crimping cable lug

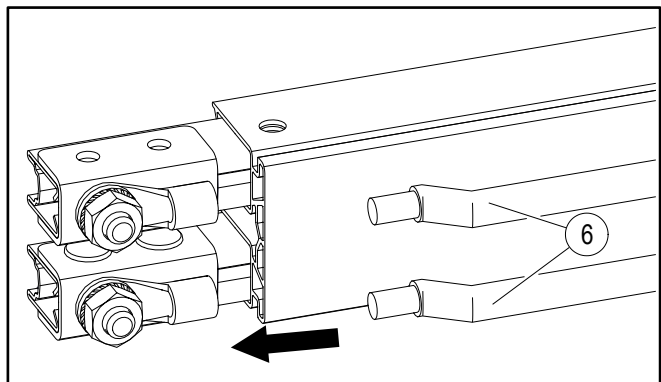

Fig. 23: Crimp connection cables with crimping cable lug

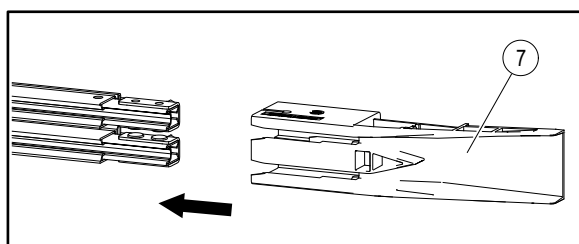

Fig. 24: Slide pickup guide over power feed point

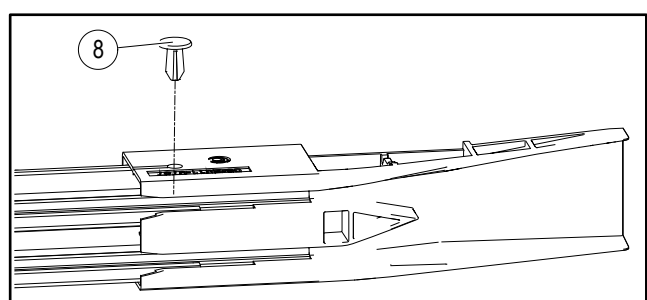

Fig. 25: Tap expanding rivet into hole

Conductor Rail System

ChargeLine 0865

If no guide is premounted on the 3-pole system, the following work steps must be carried out:

- Strip the connection cable ends and crimp them using the crimping cable lugs.
- Slide the power feed terminals into the conductor bar. Ensure that the power feed terminal is in contact with the conductor bar.
- Slide the guide over the conductor rail end.
- Tighten the cylinder screw with a torque wrench, internal size 3, to 2 Nm.
- The power feed connection cables are to be connected at the end consumer by a qualified electrician. Observe local standards and guidelines.

NOTE: Ensure that the PE strip forms a continuous strip.

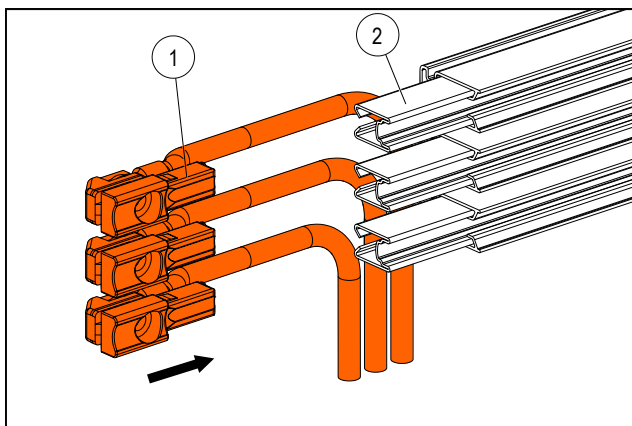

Fig. 26: Slide power feed terminals (Pos. 1) into the conductor bar (Pos. 2) Slide the terminal into the PE conductor bar.

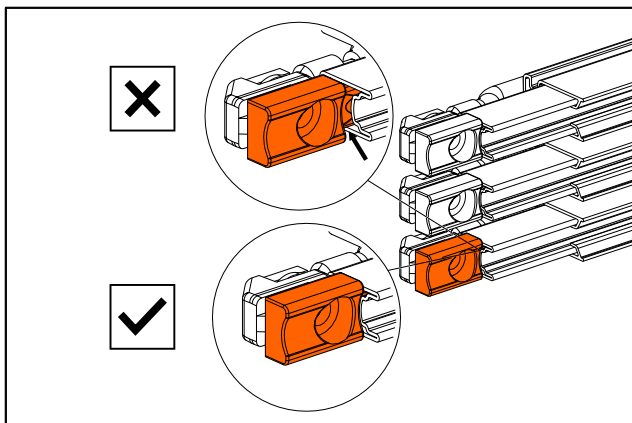

Fig. 27: Correct position of power feed terminal on conductor bar

Conductor Rail System ChargeLine 0865

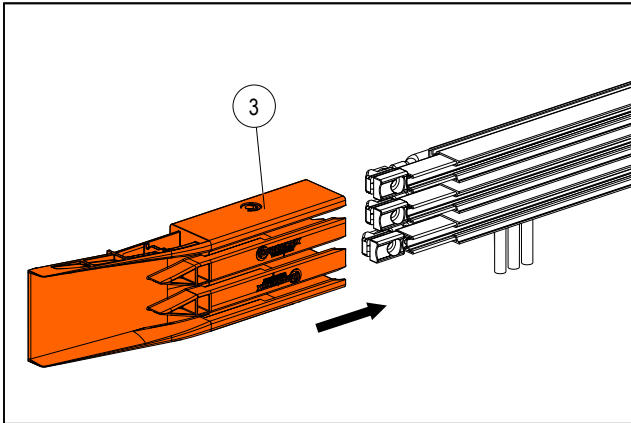

Fig. 28: Slide guide (Pos. 3) over conductor rail end

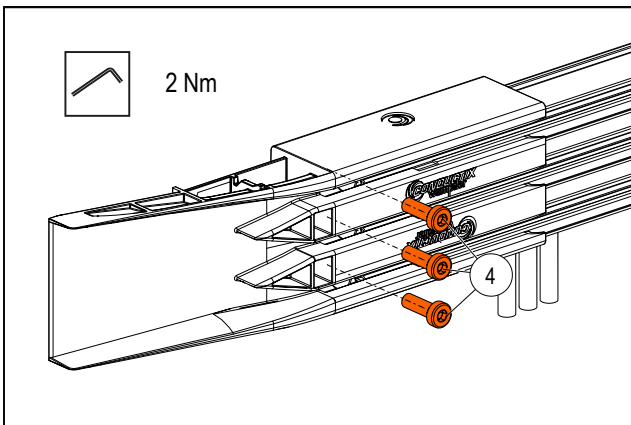

Fig. 29: Tighten cylinder screws (Pos. 4)

NOTE: The PE pole is seated either above or below. For orientation purposes, the guide has a recess in which the PE terminal must be seated. The position of the PE conductor rail must be uniformly maintained along the route.

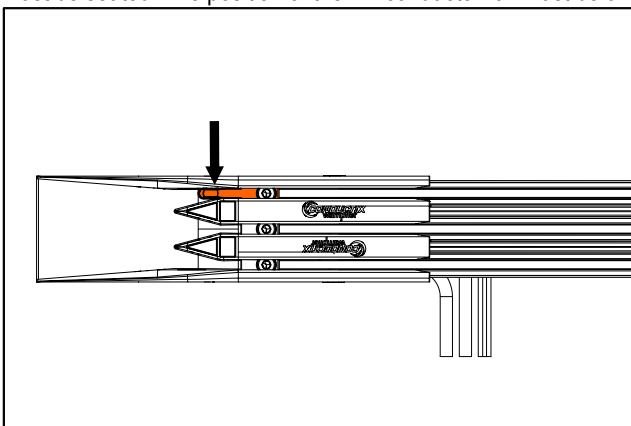

Fig. 30: PE terminal seated in guide recess

Conductor Rail System

ChargeLine 0865

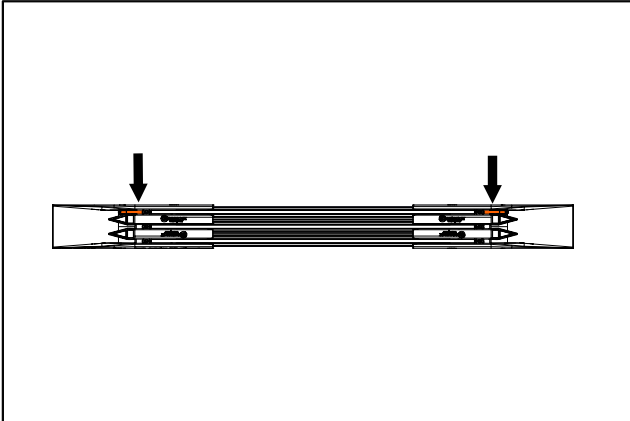

Fig. 31: PE pole above

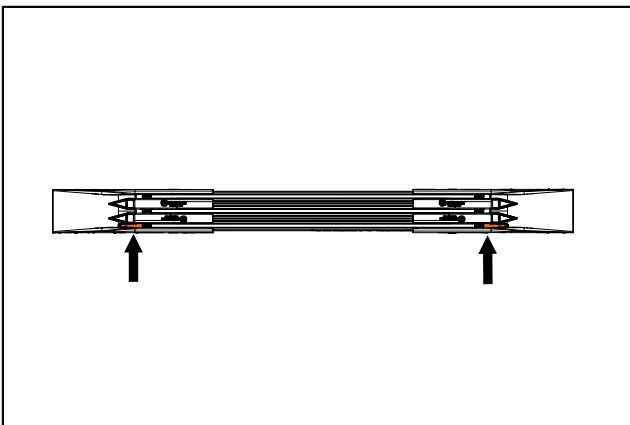

Fig. 32: PE pole below

7.5.3 Mounting the anchor points

Personnel:

- Specialist personnel

Protective equipment:

- Protective footwear
- Protective gloves (mechanical)
- Protective eyewear

Work steps:

- Together with a hanger clamp (Pos. 2), the fixing web (Pos. 3) of the pickup guide (Pos. 1) can be used as an anchor point. Hook the conductor rail (Pos. 4) into the hanger clamps so that an anchor point is created and the conductor rail cannot expand.

Conductor Rail System

ChargeLine 0865

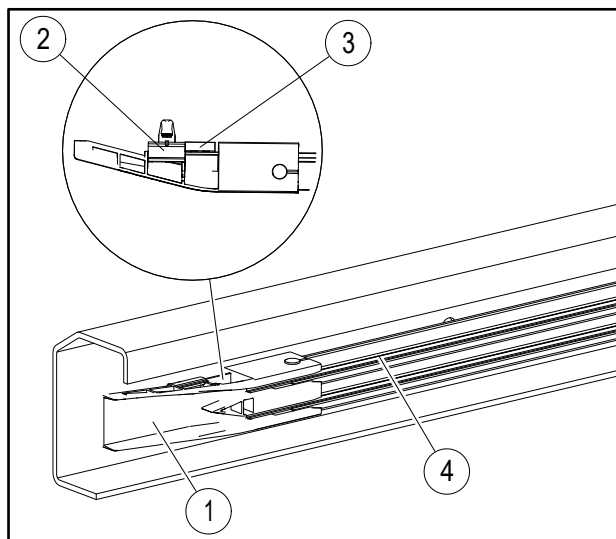

Fig. 33: Conductor rail (Pos. 4) cannot expand

Pos.	Name
1	Pickup guide
2	Hanger clamp
3	Fixing web
4	Conductor rail

7.5.4 Mounting the expansion joint

Personnel:

- Specialist personnel

Protective equipment:

- Protective footwear
- Protective gloves (mechanical)
- Protective eyewear

- The pickup guide with the fixing web may only be located on one side of the system. At the other end, the fixing web must be removed.
- Because the individual conductor bars are combined in one component, the entire conductor rail expands together.
- The connector caps are firmly connected to the conductor bars and move in line with the expansion of the conductor bars.
- The fixing web on the pickup guide, together with the hanger clamp, is the conductor rail anchor point. Only one fixing web may be installed per conductor rail.
- The use of expansion elements is not planned in cases of adherence to the max. system length, permissible temperature range and installation specifications.
- The conductor rail system expands along the length of the fixing web (approx. 16 mm). This provides sufficient expansion for systems up to a length of 100 m (depending on environmental conditions and technical parameters).

Conductor Rail System ChargeLine 0865

The maximum permitted length of a Conductor Rail 0865 (+ extension with Conductor Rail 0835) depends on the supporting construction/substructure and the given temperature. The permitted length can be found in the following table:

ΔT in Kelvin	Intermediate distance a	Installed on steel	Installed on aluminium
10 K	96 m	100 m	100 m
20 K	48 m	100 m	100 m
30 K	32 m	100 m	80 m
40 K	24 m	80 m	60 m
50 K	20 m	65 m	48 m

Work steps:

- Break the fixing web (Pos. 1) away at the rear of the pickup guide and hook the conductor rail into the hanger clamps. This creates an expansion space of $20 \text{ mm} \pm 9 \text{ mm}$, so that the rail can slide back and forth in the hanger clamp without any problems. The expansion joint provides sufficient expansion for systems up to a system length of 100 m (depending on the ambient conditions).

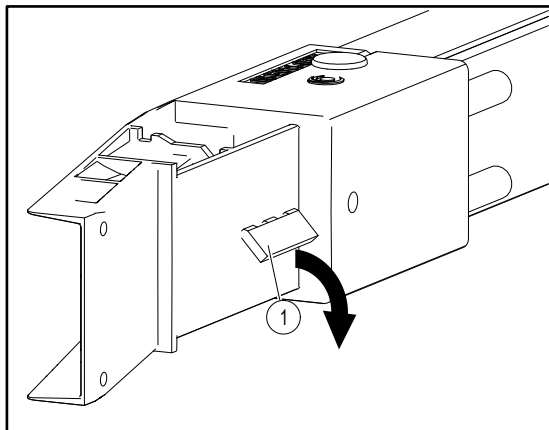

Fig. 34: Break away fixing web (Pos. 1)

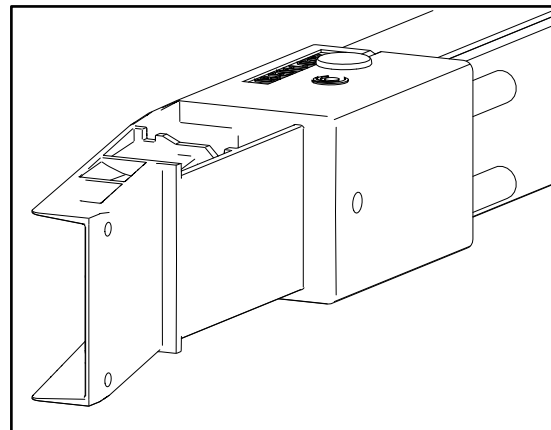

Fig. 35: Expansion joint has been produced without a fixing web

Conductor Rail System

ChargeLine 0865

Determine the position of the hanger clamp from the expansion joint:

The position of the hanger clamp from the expansion joint should be central.
The current collector must be de-energized outside the conductor bar.

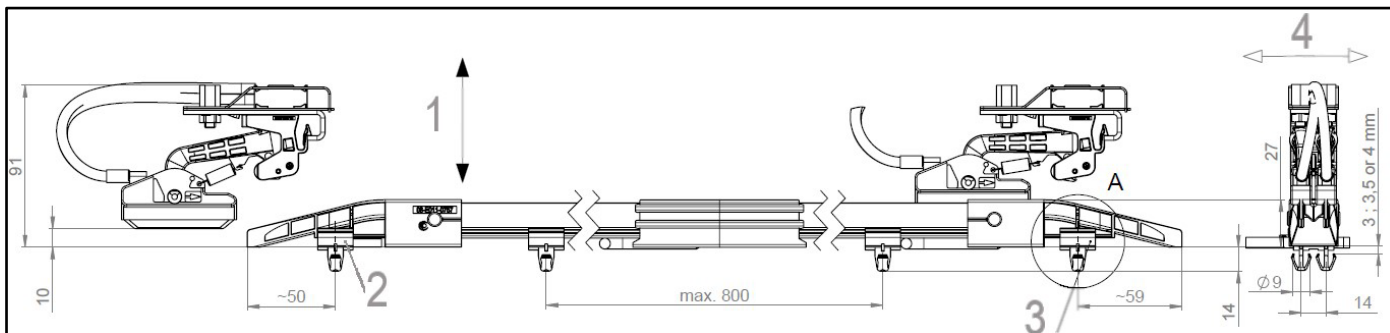

Fig. 36: 0865 arrangement

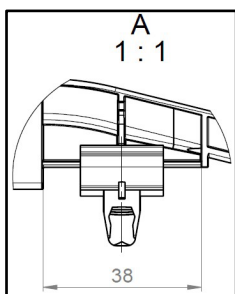

Fig. 37: Sliding bearing

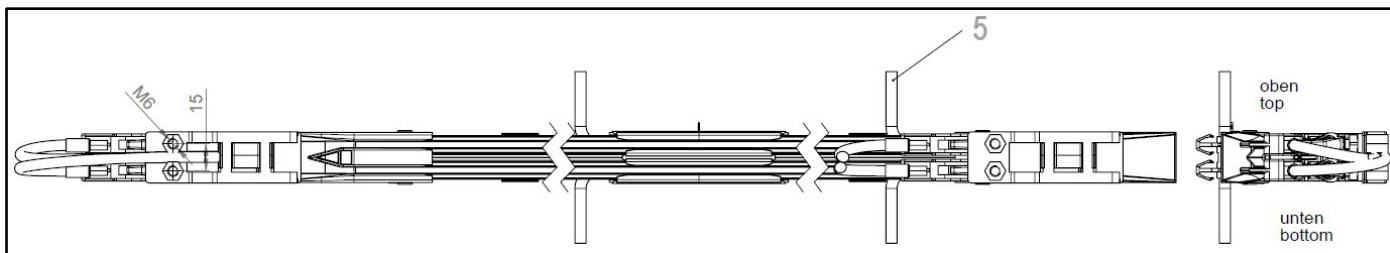

Fig. 38: 0865 arrangement (top view)

Pos.	Name
1	Working stroke ± 5 mm
2	Anchor point
3	Sliding bearing 16 mm
4	Lateral deflection ± 3 mm
5	Cable 6 mm ² (single insulated)

Conductor Rail System

ChargeLine 0865

7.5.5 Connecting the Conductor Rail System 0835



The Conductor Rail 0865 can be connected to the Conductor Rail 0835. See MAL0835-0001 for connection to Conductor Rail 0835.



DANGER!

Fire hazard due to dismantled connectors and connector caps!!

The connectors cannot be removed. Dismounted connectors are defective and must not be used because they are deformed during dismantling and their trouble-free function can no longer be guaranteed.

- The connector may only be installed on the level.
- The connectors must be chosen to match the material from which the conductor bars are made, i.e. it must be a connector for a copper conductor bar.
- The connection must not be bent or twisted.
- When using copper conductor bars, use copper-plated connectors.

- For modules with a premounted connector cap, care must be taken to ensure that the orientation is always the same, i.e. the arrow in the connector cap must point upward:

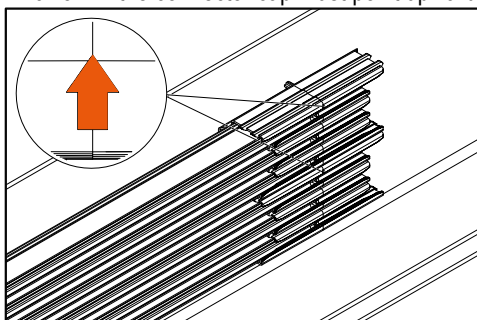

Fig. 39: Observe connector cap orientation

7.5.6 Trimming the conductor rail



The Conductor Rail 0835 or the Conductor Rail 0865 may be affected by a length adjustment.

See MAL0835-0002 for length adjustment of Conductor Rail 0835.



ATTENTION!

Only an open Conductor Rail 0865 may be sawn.

All rail lengths are configured. The sides with pickup guides and power feeds must not be adjusted!

Conductor Rail System

ChargeLine 0865

7.5.7 Hanging the conductor rail

→ Hook the conductor rail into the hanger clamps.

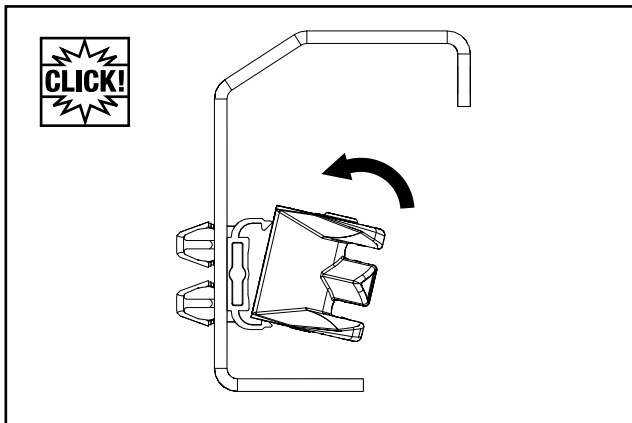

Fig. 40: Hook rail into hanger clamp

7.5.8 Mounting the current collector

Depending on the driving direction of the system, a distinction is made between reversing and towing operations for double current collectors.

NOTE: Incorrect use of the different operation types will result in uneven wear of the sliding contacts. This reduces the service life of the sliding contacts. If a double current collector is used in the incorrect operation type, the collector head must be replaced since a different sliding contact and a different spring are required for the correction and simply reattaching its original spring is not sufficient.

Towing operation:

Towing operation is used in systems where movement is predominantly in one direction. Travel in the opposite direction is possible. The arrows on the collector head point in the driving direction.

Reversing operation:

Reversing operation is used in systems where the direction of movement is evenly distributed.



Always include redundancy for PE current collectors!

For standard-compliant use (DIN EN 61140-2016-7.3.5.1 and DIN EN 60204-1-2018), Conductix-Wampfler recommends always including a redundancy for PE current collectors.

Further measures must be taken depending on the applications and the results of the operator's risk assessment.

Conductor Rail System

ChargeLine 0865

Personnel:

- Qualified electricians

Protective equipment:

- Protective footwear
- Protective gloves (mechanical)
- Protective eyewear

Work steps:

→ Screw the current collector unit onto the end consumer. Ensure that the orientation is centered and observe the working stroke.

NOTE: The connection cables are correctly set and must not be changed.

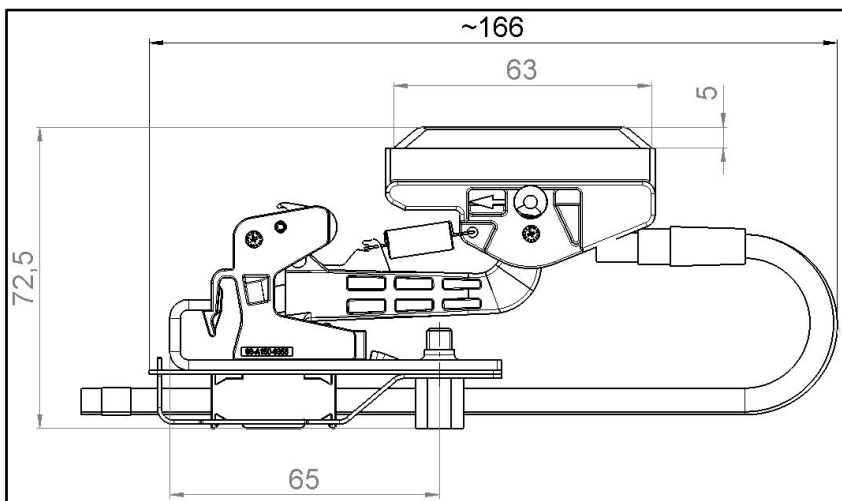

Fig. 41: Current collector installation dimensions



ATTENTION!

Current collector connection cables:

- No tensile forces and/or directional and/or compressive forces may have effect on connection cables.
- Connection cables must not be laid atop.
- Do not compress or kink connection cables.
- Do not fix or bundle connection cables with cable ties.
- Do not provide connection cables with identification labels.
- Do not twist the connection cables.
- Use connection cables from Conductix-Wampfler or highly flexible connection cables similar to Conductix-Wampfler cables.



A current collector insertion from above means a great deal of grime and soiling, which leads to an increased cleaning effort.

Conductor Rail System

ChargeLine 0865

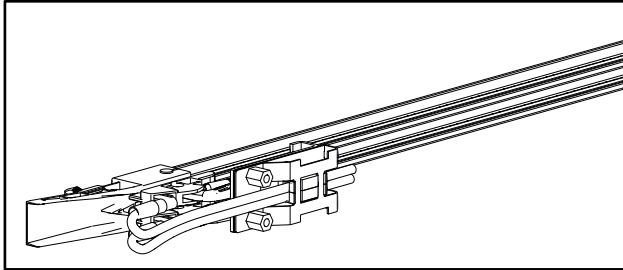

Fig. 42: Lateral insertion of current collector

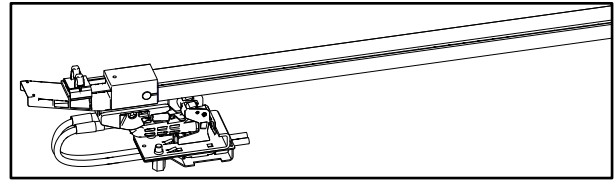

Fig. 43: Current collector inserted from below

Conductor Rail System

ChargeLine 0865

8 Commissioning

Personnel:

- Specialist personnel
- Qualified electricians

Protective equipment:

- Protective footwear
- Protective gloves (mechanical)

Requirement: The system has been disconnected from the power supply according to the Five Safety Rules.

8.1 Check list

8.1.1 Checking the system

Check points:

- Ambient conditions correspond to the planned design (ambient temperature, humidity, etc.).
- The system has been checked against the installation plan (power feeds, anchor points, etc. are complete and in the correct position).
- The installation position of the conductor rail and current collector is correct (e.g. height, phase spacing).
- Installed components are correctly unmounted, undamaged, clean and dry.
- There are no interfering contours or parts in the working area of the current collectors.
- PE is in the correct position.
- The necessary covers and barriers are available.
- The connection cables are dimensioned according to the loads and ambient conditions and/or the installation conditions.

Consequences of non-compliance:

- The system is not operational.

8.1.2 Checking the conductor rail

Check points:

- There is no visible change in height on straight sections.
- There is no lateral displacement on straight sections.
- No "waves" are visible on the installed conductor rails.
- Conductor rail runs parallel to the current collector section.
- There is no lateral displacement from the conductor rail to the current collector.
- The insulation profile is fully hooked into the hanger clamps.
- The conductor bar may only be visible at the access opening for the current collector.
- Contact surfaces of the conductor bars are clean and free of soiling, oxidation and pitting corrosion.
- Transitions between the conductor rail and other components (power feed, end caps, connectors, etc.) are checked for secure connection.
- The conductor bar and insulation profile are burr-free at the ends.
- The collector heads do not jam and slide through the conductor rail without obstruction.

Conductor Rail System

ChargeLine 0865

Consequences of non-compliance:

- Uneven wear of sliding contacts and conductor rail.
- Poor electrical contact.
- Conductor rails can come loose from the hanger clamps if they are not fully hooked into the hanger clamps.
- Risk of electric shock and fire hazard.

8.1.3 Checking the hanger clamps

Check points:

- The hanger clamps are installed with the correct spacing from each other and from the connector caps in accordance with the installation plan.
- The hanger clamps are aligned at right angles to the conductor rail.
- The conductor rail can slide freely in the hanger clamps.

Consequences of non-compliance:

- Damage to the conductor rail system such as waves in the conductor rail, bent conductor rail, pulled connectors or broken hanger clamps.

8.1.4 Checking the connectors

Check points:

- The conductor bars at the connection joint are aligned to each other without displacement.
- Care was taken to ensure that the insulation profile and conductor bar were free of burrs if the conductor rails were trimmed on site.
- The gap between the two conductor bars at the connection point is approx. 2.5 mm.
- The insulation profile is completely enclosed by the connector cap.
- The specified tightening torques were observed.
- The arrow on the connector cap points upward.

Consequences of non-compliance:

- Increased wear of the sliding contacts.
- Risk of electric shock and fire hazard.
- Poor electrical contact.

8.1.5 Checking the expansion joint

Check points:

- Only one fixing web may be broken away. At least one fixing web must also be broken away.
- The length of the conductor rail was coordinated with supporting construction/substructure and ambient temperature.

Consequences of non-compliance:

- Damage to the conductor rail system such as waves in the conductor rail or bent conductor rail.
- Poor electrical contact.

Conductor Rail System

ChargeLine 0865

8.1.6 Checking the power feed

Check points:

- No tensile forces and/or directional forces and/or compressive forces act on the power feed. The connection cables must not be laid atop, compressed, kinked or twisted. Cable ties must not be used to fix or bundle the connection cables and the connection cables must not be provided with identification labels.
- The screws of the power feed terminals are tightened to the specified tightening torques.
- The power supply connection cables are flexibly laid.
- The power feed terminal is pushed completely into the conductor bar.
- The guide is correctly mounted and completely covers the power feed.

Consequences of non-compliance:

- Risk of electric shock and fire hazard.
- Disconnection of the electrical connection and damage to the connection cables.
- Optimal energy transmission cannot be ensured.
- The power feed terminals can become detached from the conductor rail.
- Poor electrical contact.

8.1.7 Checking the pickup guides

Check points:

- The spacing between the pickup guide and the next hanger clamp is maintained.
- The pickup guide is mounted to the current collectors within the permitted vertical and horizontal tolerance.

Consequences of non-compliance:

- Correct insertion of the current collectors into the conductor rail is not ensured.

8.1.8 Checking the current collectors

Check points:

- The current collectors (not engaged) are visually and mechanically in order (without damage, movements are smooth).
- The current collectors are correctly attached and aligned.
- The installation spacing for the current collectors (engaged) is correct according to the specification.
- The current collector connection cables are laid free of directional and tensile forces. The cables must not exert compressive or torsional forces on the collector heads.
- The freedom of movement of the collector heads is not restricted.
- The collector heads do not jam and slide through the conductor rail without resistance.

Consequences of non-compliance:

- The sliding contacts wear unevenly.
- The current collectors can break off.

Conductor Rail System

ChargeLine 0865

8.1.9 Checking the electrical system

Check points:

- The insulation resistance was measured.
- All metal components (e.g. substructure/ supporting construction) were grounded according to regulations.
- All electrical protection devices are installed, tested and functional.
- The specified national electrical tests have been conducted.

Consequences of non-compliance:

- Risk of electric shock and fire hazard.

8.1.10 Other system checks

Check points:

- A test travel was carried out at low speed in compliance with the safety regulations. Damage to the system can be detected in good time before operation.
- The current collector slides well over the connection and disconnection points.
- All safety symbols and type plates have been affixed.
- All tools and materials have been removed.
- The operating personnel have been instructed.

Consequences of non-compliance:

- Damage to the system.
- Collisions during operation.

8.2 Measuring the insulation resistance

Personnel:

- Qualified electricians

Tools:

- Resistance meter according to IEC / EN 61010-1

Requirement:

Disconnect the system from the power supply according to the Five Safety Rules.

Work steps:

- Connect the resistance meter to the appropriate measuring points.
- Set the resistance meter to the test voltage.

For systems with a rated voltage of < 1000 V, the measured DC voltage must be 1000 V and the insulation resistance must be $\geq 1.0 \text{ M}\Omega$.

- Start the measurement and observe the resistance meter display.
- Document the measured values including a sketch of the measured sections in the corresponding measurement log.
- Dismount the measurement setup and ensure that the system is ready to be switched on again.
- Switch the system back on and check for proper function.

9 Operation

Personnel:

- Operator
1. Normal operation is the uninterrupted power supply to the mobile end consumer.
 2. If faults occur, the conductor rail system must be switched off and secured against being switched back on.
See Section 1.8 and Section 10.1
 3. If normal operation has been interrupted and operation must be resumed, the following points must be observed:
 - Ensure that all work has been completed.
 - There must be no coarse soiling or objects in the conductor rails.
 - The full length of the sliding contacts must be in contact with the conductor bar.
 - Measure the insulation resistance. See Section 8.2

10 Faults

10.1 Fault correction

Personnel:

- Qualified electricians

Protective equipment:

- Protective footwear
- Protective gloves (mechanical)
- FFPE protective mask
- Protective eyewear

Requirement:

Disconnect the system from the power supply according to the Five Safety Rules.

10.1.1 Faults on the current collector and sliding contacts

Fault observed	Possible cause	Solution	Personnel
Sliding contacts are unevenly worn.	The collector head's range of movement is restricted.	<ul style="list-style-type: none"> • Check the current collector connection cables for directional, torsional and tensile forces. • Lay connection cables without affecting forces. • Allow the current collector to move freely, e.g. remove any affixing cable ties. 	Qualified electricians
	Contact force is too high or low.	<ul style="list-style-type: none"> • Check that the correct Class 6 connection cables according to DIN VDE 0295 have been used. • Check and correct the installation dimensions of the current collector. Fig. 41 • Check the tolerance range of the overall system on the X-axis and Y-axis. Fig. 9 • Check the current collector for parallelism to the conductor rail and correct. 	

Conductor Rail System

ChargeLine 0865

Fault observed	Possible cause	Solution	Personnel
Sliding contact insulation is worn away on the side down to the sliding contact.	The height of the current collector is not correctly adjusted to insertion from the side.	<ul style="list-style-type: none"> Replace the collector heads and align the height correctly. If the problem persists after replacement and height adjustment, the current collectors may be installed slightly higher above the conductor rail axis. The Conductix-Wampfler Expert System Team will be happy to assist you with any questions.	Qualified electricians

Fault observed	Possible cause	Solution	Personnel
Sliding contacts wear out too fast.	Sharp edges on power feed terminals, conductor rails and/or at the connection points of the individual conductor rails.	<ul style="list-style-type: none"> Deburr sharp edges. 	Qualified electricians
	Conductor rail is soiled or has burnt areas.	<ul style="list-style-type: none"> Check the system, e.g. for excessive current values. Clean the conductor rail If the contact surfaces of the conductor rail are damaged, replace the affected section. 	
	Contact force is too high.	<ul style="list-style-type: none"> Check that the correct Class 6 connection cables according to DIN VDE 0295 have been used. Check and correct the installation dimensions of the current collector. Fig. 41 Check the tolerance range of the overall system on the X-axis and Y-axis. Fig. 9 Check the current collector for parallelism to the conductor rail and correct. 	

Fault observed	Possible cause	Solution	Personnel
Energy supply is not continuous.	End and section power feeds are not installed according to the manufacturer's specifications.	<ul style="list-style-type: none"> Check the crimp connection between cable lug and connection cable and re-crimp if necessary. 	Qualified electricians

Conductor Rail System

ChargeLine 0865

Fault observed	Possible cause	Solution	Personnel
	Contact force is too low.	<ul style="list-style-type: none"> Check that the correct Class 6 connection cables according to DIN VDE 0295 have been used. Check and correct the installation dimensions of the current collector. Fig. 41 Check the tolerance range of the overall system on the X-axis and Y-axis. Fig. 9 Check the current collector for parallelism to the conductor rail and correct. 	
	Collision with system components	<ul style="list-style-type: none"> Examine the system layout. Attach affected components for collision-free operation. Check the lateral clearance of 4 mm between the conductor rail and metallic components and correct if necessary. 	
	Abrasion of the sliding contacts has accumulated at the end points of the section.	<ul style="list-style-type: none"> Cleaning the conductor rail 	
	Oblique removal of sliding contacts	<ul style="list-style-type: none"> Check the current collector for parallelism and correct. 	

10.1.2 Faults on the conductor rail

Fault observed	Possible cause	Solution	Personnel
The insulation profile is not hooked into the hanger clamps.	Improper installation of the hanger clamp and/or the conductor rail.	<ul style="list-style-type: none"> Check the hanger clamp and conductor rail for damage and check that they have been correctly installed. Replace damaged components if necessary. 	Qualified electricians

10.2 Handling unknown faults

Conductix-Wampfler must be contacted if unknown faults occur.

Conductix-Wampfler GmbH
Rheinstrasse 27 + 33
D – 79576 Weil am Rhein – Markt
Phone: +49 (0) 7621 662-0
Fax: +49 (0) 7621 662-144
Email: info.de@conductix.com
www.conductix.de
Country of origin: Germany

Worldwide sales and service location addresses:

www.conductix.contact

11 Maintenance and Service

11.1 Maintenance plan

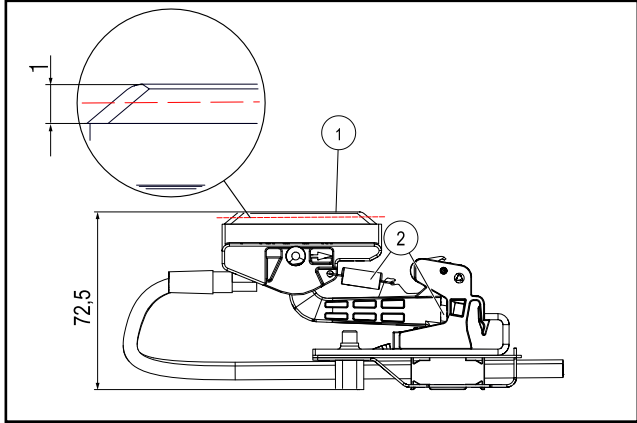
Interval	Service work	To be performed by						
Daily	Visual inspection ■ Are coarse dirt or objects in the conductor rail?	Operator						
4 weeks after commissioning Afterward: Every 3 months	<p>Visual inspection:</p> <ul style="list-style-type: none"> ■ Check if sliding contacts are worn in the contact area. → Replace the current collector if the wear limit of 1 mm (sliding contact insulation to sliding contact) is reached or exceeded. <div data-bbox="395 869 1034 1290" style="border: 1px solid black; padding: 5px;">  </div> <p><i>Fig. 44: Sliding contact wear limit</i></p> <table border="1" data-bbox="408 1357 1046 1473"> <thead> <tr> <th>Pos.</th> <th>Name</th> </tr> </thead> <tbody> <tr> <td>1</td> <td>Conductor rail contact surface</td> </tr> <tr> <td>2</td> <td>Spring</td> </tr> </tbody> </table> <ul style="list-style-type: none"> ■ Check sliding contact insulation for cracks and scraping. → Replace the current collector if the insulation is damaged and the sliding contacts are visible, or the sliding contact insulation has cracks. ■ Check the insulation for wear, soiling and burn marks. → If necessary, clean the insulation profile or repair the defect. ■ Ensure that there are no constrictions inside the individual poles of the insulation profile (dust or adherent soiling). → Clean the insulation profile with a vacuum or brush, or replace. ■ Ensure that the conductor rail insulation is not impaired by foreign objects (shavings, fluids, soiling, etc.) (risk of short circuit). → Clean or the restore components, if it is not possible to fully restore the insulating properties, replace the components. 	Pos.	Name	1	Conductor rail contact surface	2	Spring	Specialist technician
Pos.	Name							
1	Conductor rail contact surface							
2	Spring							

Conductor Rail System

ChargeLine 0865

	<p>Functional check:</p> <ul style="list-style-type: none">■ Ensure correct contact force<ul style="list-style-type: none">→ Check for the presence of springs.→ Check the correct installation height of the current collector 72.5. (see Fig. 44)→ Change the fastening position in the event of deviation.→ The required contact force is ensured by the correct fastening position of the current collector. However, if a measurement of the contact force is required, this can be carried out, e.g. with a spring balance.■ Check the freedom of motion of each individual collector arm.<ul style="list-style-type: none">→ If necessary, clean or replace the entire current collector.■ Check the vertical and lateral tolerance of the current collectors relative to the conductor rail.<ul style="list-style-type: none">→ If necessary, correct the mounting position.→ If necessary, clean the insulation profile or repair the defect.	Specialist technician
--	---	-----------------------

11.2 Replacing the conductor rail within a section

See MAL0835-0002 for replacing the conductor rail within a section.

11.3 Cleaning the conductor rail

See MAL0835-0002, WV0800-0001 and WV0800-0002 for cleaning the conductor rail.

12 Disassembly and Disposal

12.1 Disassembly

Personnel:

- Specialist personnel

Protective equipment:

- FFPE protective mask
- Protective footwear
- Protective gloves (mechanical)
- Protective clothing

Tools:

- Hexagon wrench SW 3
- Cutting tool
- Pliers

Requirement:

The system has been disconnected from the power supply according to the Five Safety Rules.

Work steps:

- Loosen screw connections.
- Insert a slotted screwdriver between the hanger clamp and the conductor rail and turn it to remove the conductor rail from the hanger clamp.
- Remove the power feeds, connectors and end caps from the conductor rail.
- Separately dispose of all disassembled components according to their respective material group.
- Remove the hanger clamps from the support profile using pliers.

CAUTION: Risk of injury when sawing the connector due to the saw jumping. When disconnecting the conductor rail, maintain a distance of at least 100 mm from the end of the insulation profile.

12.2 Disposal

Personnel:

- Specialist personnel

Protective equipment:

- Protective footwear
- Protective gloves (mechanical)

When the system has reached the end of its service life, the disassembled components must be separated and disposed of in an environmentally friendly manner.

- Insulating profile: Plastic
- Conductor bar: Copper
- Connector cap and power feed cap: Plastic
- Connector pins, connector terminals and power feed terminals: Copper alloy
- Current collector: Polyamide, steel
- Sliding contact: Copper graphite or graphite

Environmental damage due to improper disposal!

Valuable raw materials can be reused through environmentally friendly disposal.



- Observe locally applicable disposal regulations.
- Have a specialized company carry out the disposal if necessary.
- Comply with the Hazardous Substances Ordinance, particularly the regulations on handling hazardous substances.
- Dispose of materials marked for recycling using the respective recycling process.



Conductor Rail System

ChargeLine 0865

13 Additional Documents

Seq. No.	Document No.	Document Name
1	WV0800-0001	Cleaning Conductor Rails
2	WV0800-0002	Conductor Rail Maintenance Plan
3	MAL0835-0002	Mounting Instructions MultiLine 0835

14 Approvals and Standards

The Declaration of Conformity for this product can be requested from Conductix-Wampfler.

Conductix-Wampfler GmbH
Rheinstrasse 27 + 33
D – 79576 Weil am Rhein – Märkt
Phone: +49 (0) 7621 662-0
Fax: +49 (0) 7621 662-144
Email: info.de@conductix.com
www.conductix.de
Country of origin: Germany

Worldwide sales and service location addresses:

www.conductix.contact

15 Index

Assemblies description.....	19	Intended use	5
Commissioning.....	42	Limitation of liability.....	11
Copyright.....	11	Maintenance and service	51
Declaration of conformity.....	56	Maintenance plan.....	51
Disassembly.....	53	Personnel.....	7
Disposal.....	53	Product description	17
Explanation of symbols	4	Storage.....	22
Fault correction table.....	47	Technical data.....	14
Function.....	17	Tools	23
Installation	23	Transport.....	22

Conductix-Wampfler GmbH
Rheinstraße 27 + 33
79576 Weil am Rhein - Märkt
Germany

Phone: +49 (0) 7621 662-0
Fax: +49 (0) 7621 662-144
info.de@conductix.com
www.conductix.com



Importer for the United Kingdom:
Conductix-Wampfler Ltd.
1, Michigan Avenue
Salford
M50 2GY
United Kingdom

Phone: +44 161 8480161
Fax: +44 161 8737017
info.uk@conductix.com
www.conductix.com